

# Operating Instructions

## www.TURNSTILES.us

### Type MPT 53

**Contents**

- 1. Delivery ..... 2
- 2. Safety ..... 3-4
- 3. Description and operation ..... 5
- 4. Technical Data ..... 6
- 5. Foundation ..... 6-9
- 6. Assembly and installation ..... 10-13
- 7. Electrical connection ..... 14-15
- 8. Access control devices ..... 16
- 9. Commissioning ..... 17
- 10. Technical support ..... 17
- 11. Spare parts and accessories ..... 17-18
- 12. Warranty ..... 19
- 13. Controller MSC 10 ..... 20-22

## 1. Delivery

The Security Turnstile consists of:

In addition to the items shown in the drawing below, we also provide the following parts:

- 1 x Set of installation manuals
- 2 x Keys for Access door

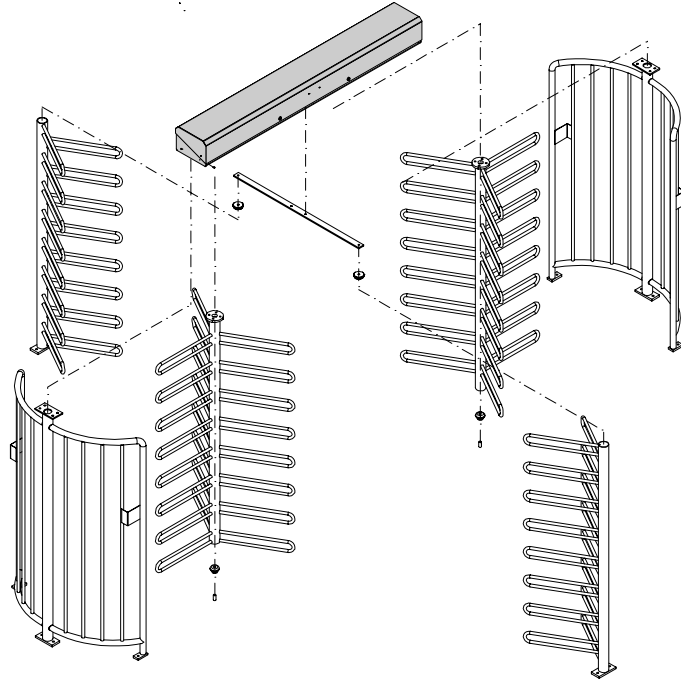

## **2. Safety**

### **2.1 General safety notes**

www.TURNSTILES.us pedestrian turnstile has been designed, built, and tested according to the latest available technology. The product has left the factory in a fully operational and safe condition. However, it is imperative that the installation is carried out in accordance to this operating manual. Therefore, it is vital to read this operating manual in full before starting the installation and that all the safety notes and remarks are being observed.

Any liability and warranty is declined by the manufacturer in the case of incorrect use and use for purposes other than intended by the design.

### **2.2 Intended Use**

www.TURNSTILES.us pedestrian turnstile MPT\* shall only be used to control pedestrians entering or exiting restricted areas.

www.TURNSTILES.us Universal Controller MUC\* shall only be used for controlling the pedestrian turnstile MPT\*. Any other use is not permitted.

Conversions and modifications to the turnstile or to the control modules are not permitted.

Only original spare parts and accessories from www.TURNSTILES.us shall be used.

## 2.3 Identification of risks/SAFTY

Possible risks are identified with the following symbols in the operating instructions:



### Warning!

This symbol is used in this manual to warn installers of potential harm. Please read and observe these instructions very carefully.



### Caution!

This symbol is used in this manual to highlight those actions or states, which represent a potential hazard to pedestrian, personnel, property, and equipment. Please read and observe these instructions very carefully.



### Note!

This symbol is used in this manual to highlight useful information for the operator and installer. Please read and observe these instructions very carefully.

## 2.4 Safety notes

- Disconnect all external opening or closing devices (remote control, control desk, etc.) during maintenance work
- Do not operate the equipment without effective anchoring to the Foundation
- A main supply power circuit breaker must be installed
- This operating manual and any other additional information must be kept in a, for all authorized person, accessible location.
- Before commissioning make sure all electrical and functional features are tested.
- The electrical wiring must comply with this instructions.
- Only certified and trained electrical technicians shall perform any electrical work.
- Before any maintenance or troubleshooting work the main power supply must be disconnected.
- Electrical voltage components like transformers, solenoids, resistors, and stator housings of motors, lamps etc. may be hot during and after operation. Do not touch such components; it can cause skin burns

### 3. Product description

The MPT series turnstiles are designed to control pedestrians entering or exiting restricted areas in high security applications. The turnstile consists of eight different components (see fig. 1). The unit can be set up for bi-directional access control by means of keys or card readers (access control devices in general). Entry and exit of the unit can either be operated in normally open or closed mode. The rotating centre column consists of 3 x 120 degree U-bars. The controller, the drive unit, and the locking device are installed inside the top powder coated sheet metal enclosure. The top enclosure provides efficient space for additional access control equipment. The locking and unlock feature of the turnstile is performed by the controller (MCU) and the electro-mechanical solenoid locking mechanism.

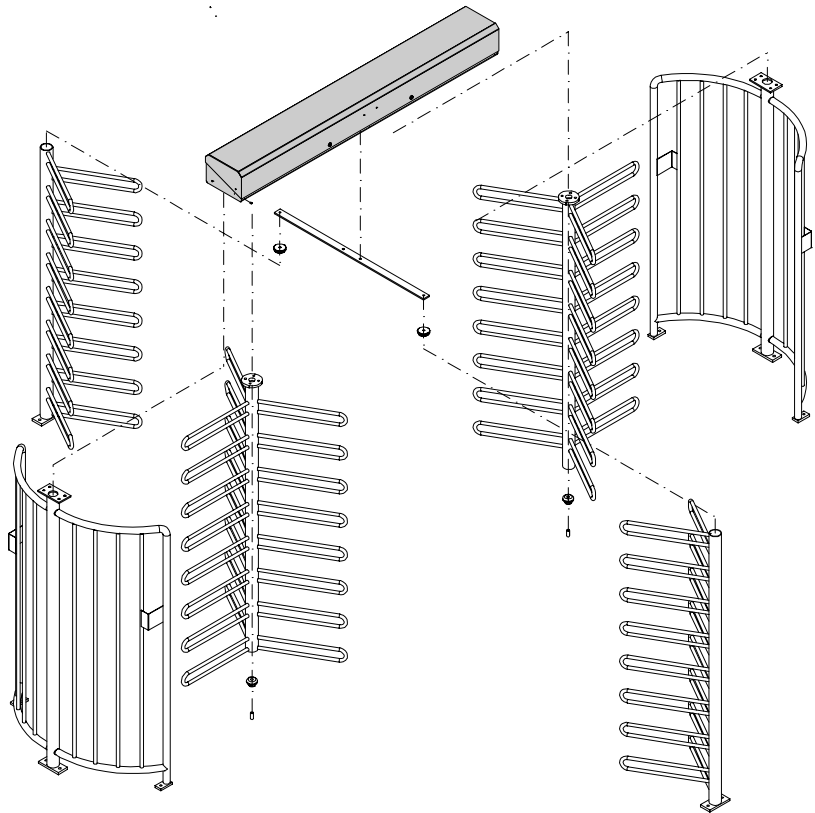

Fig.1

## 4. Technical Data

Technical Data:	Type	MPT 53
Protection	IP	54
Voltage VAC		115
Frequency	Hz	60
Current	A	5.0
Duty Cycle	%	100
Weight	lbs	700
Height	Inch	88
Width	Inch	87

## 5. Foundation

The foundation shall be constructed with at least 2500 PSI grade concrete. The mounting surface must be leveled to insure a solid base for the turnstile.

Once the concrete has set to an adequate hardness, the holes for the anchor bolts can be drilled using the dimensions shown in Fig. 2.

www.TURNSTILES.us recommends using  $\varnothing$  3/8" anchor bolts. Please refer to the anchor bolt manufacturers installation requirements.

For the dimensions, please refer to figure 2. The cables should finish a minimum of 15 ft above the concrete surface.

NOTE: This foundation is also required when installing the turnstile on pavers. See instruction for installation with pavers.

Conduit pipes (with different diameters for low and high voltage cables as per Electrical code) must be installed to run the mains supply cable and the control cables. The conduits must reach at least 2" above ground.

# Operating Instructions

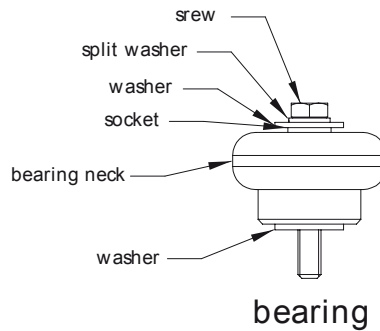
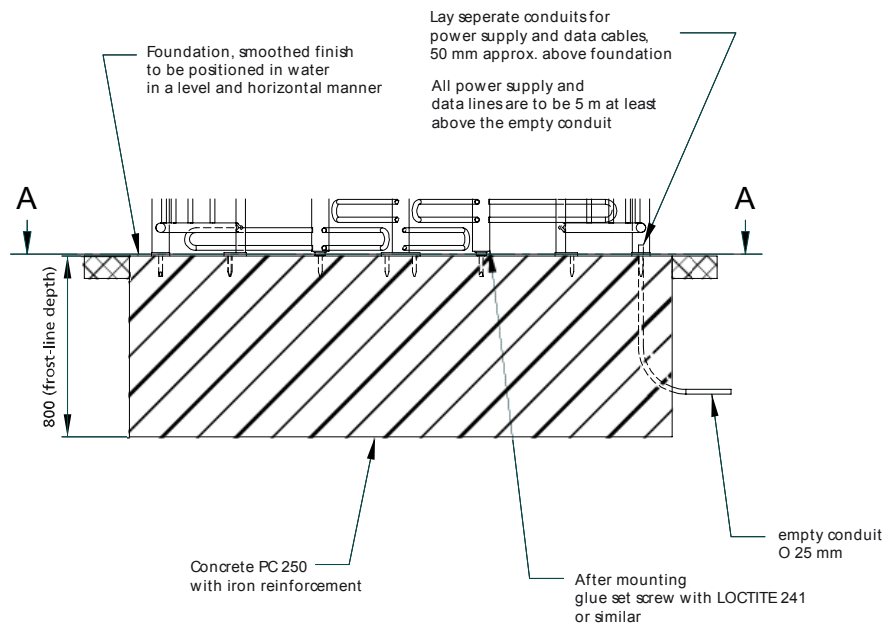
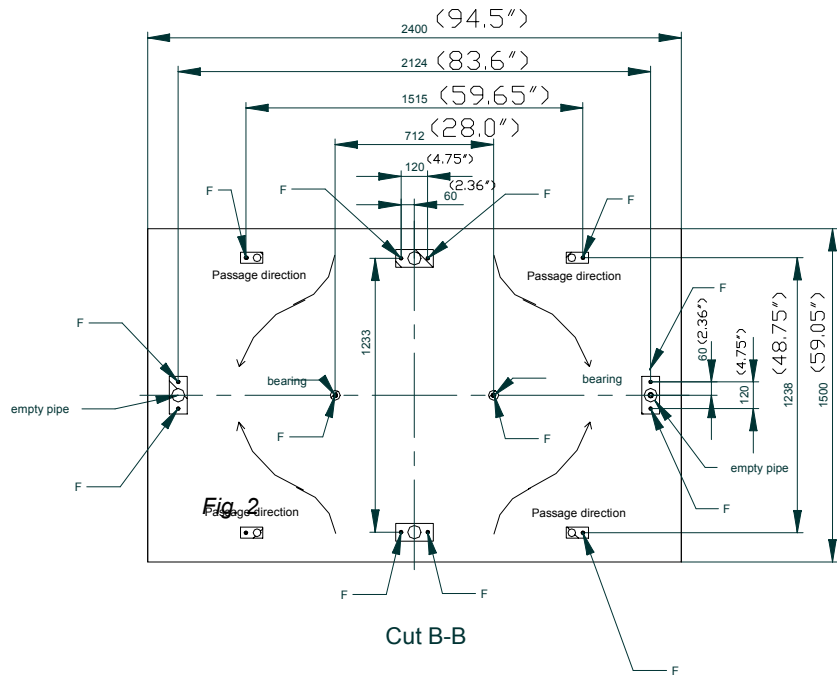

## 5.1 Foundation frame

The foundation frame is required for turnstiles to be mounted on sub ground, for example in case of pavers. A level concrete mounting surface is required for correct mounting of the foundation frame. It should be approx. 6 Inches below the finished surface.

Mounting of the foundation frame:

- Make sure to position the frame in the correct place
- drill of holes for anchor bolts
- install anchors,
- level the foundation frame before tightening the bolts
- tighten the foundation frame.

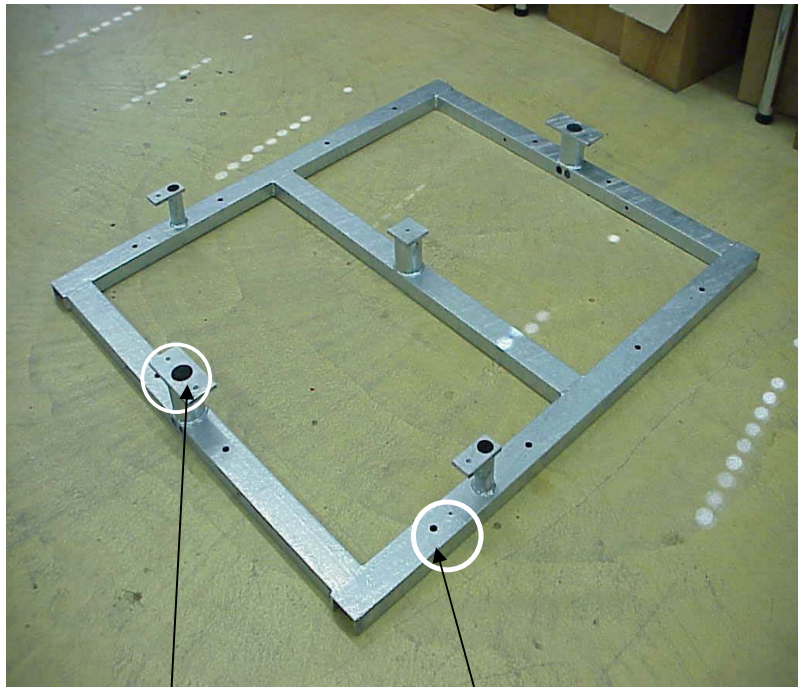

*Fig.4*

Cable routing from foundation into turnstile

Jackscrews  
For positioning the foundation  
Frame on the concrete, if necessary.

## 6. Assembly and installation

### 6.1 Installation (above ground foundation)



- Position the cage parts at its desired location based on the previously installed anchor bolts.
- Mount the components in correct order (part 1, 2..) onto the foundation; however, do not fully tighten the bolts until all components are in place. This is to compensate for tolerances from the steel manufacturing and anchor position.

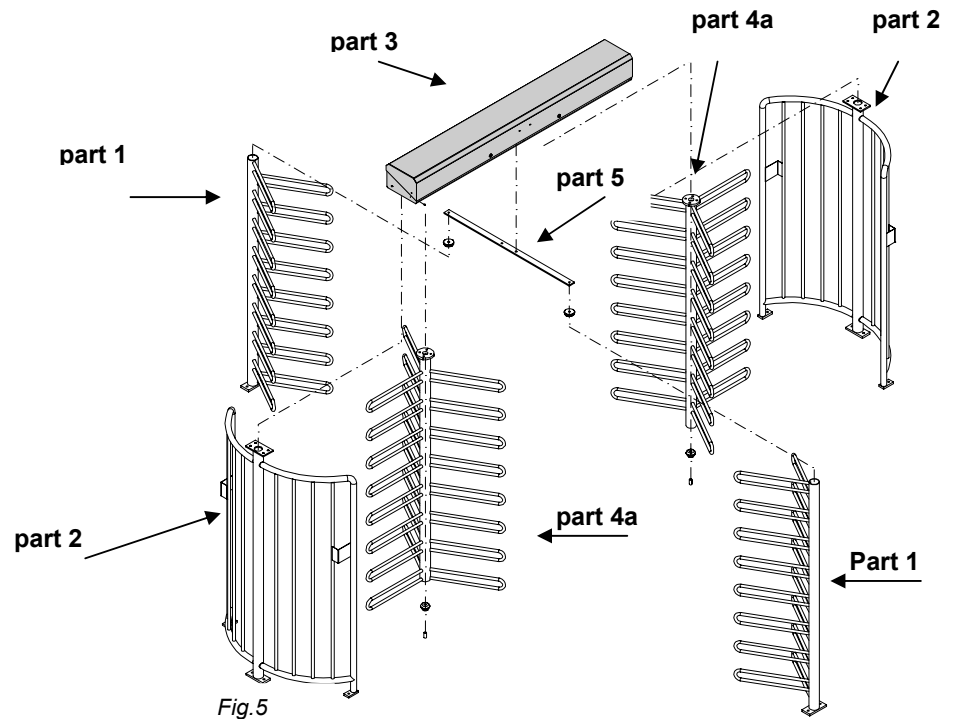

Fig.5

- Place part 3 on top of part 1 and 2. Use screws 8 x M12 x 35 and counter nut.
- Mount lower bearing (see fig. 8). Using screws M10 x 70. Make sure to lubricate the bolts when installing.
- Slide part 4 onto lower bearing, see fig. 9. then attach the center column to the upper mechanism by making use of the 4 x M16 x 40 and washers. Make sure that the turnstile is in a locked position.
- Now tighten all existing bolts.

## 6.2 Installation using the Foundation Frame

See section 5.1 Foundation frame

In this case the turnstile is mounted on the flanges of the foundation frame.

## 6.3 Opening of the top cover



*Fig.6*

The top cover is locked in place via 4 hexagon socket head screws. Unscrew the fasteners with an Allen key. (fig. 6).

Tilt the top cover away from you.

## 6.4 Placing the components

All cage components are installed to the foundation by using the 8x M8 bolts and washers that came with the shipment. After final positioning, tighten all bolts firmly.



*Fig. 7*

## 6.5 Installing the center column

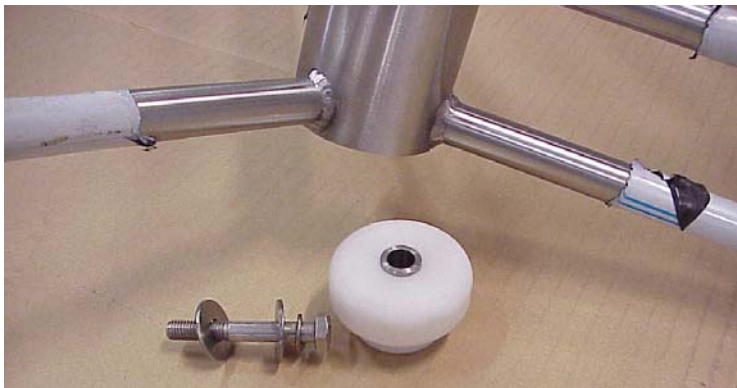

*Fig. 8*

## Operating Instructions

---



*Fig. 9*

Mount the lower bearing on the foundation and slide the centre column over it.



*Fig. 10*

Attach the center column using the provided 4x M16 bolts and washers to the flange of the upper mechanism.  
Make sure the center is in correct position (center in locked position).

## 7. Electrical Wiring

Any electrical wiring has to be done by a certified electrician in accordance with local electrical codes and the provided wiring diagram.

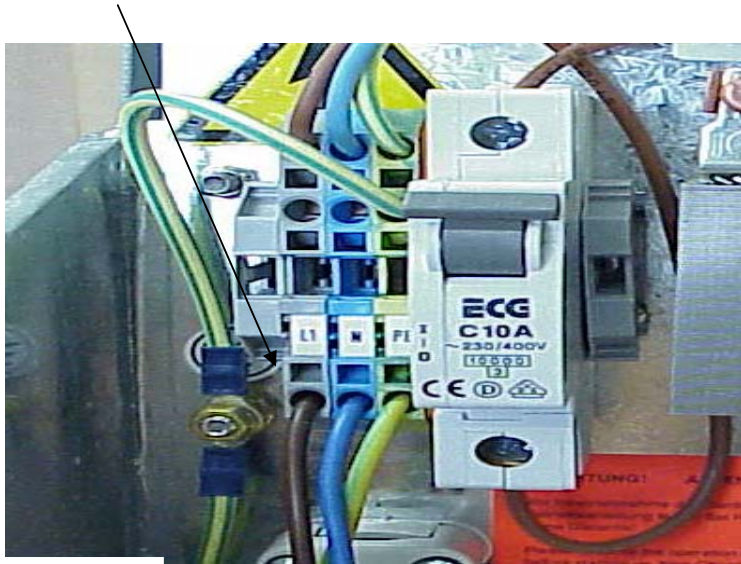

Fig.11

Main power connection Fig. 11

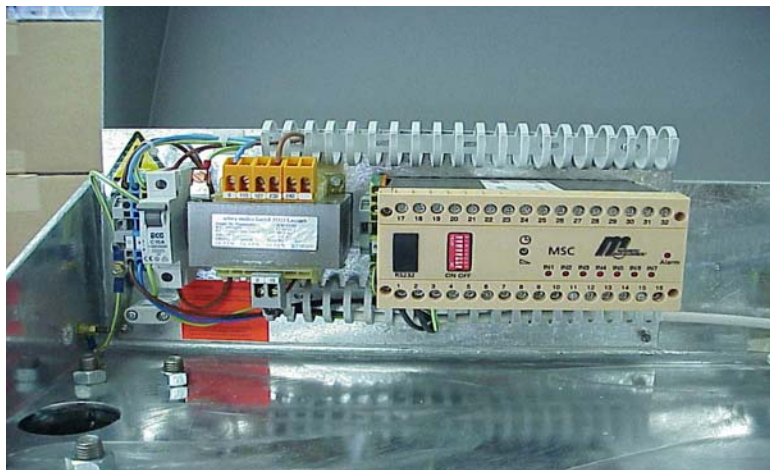

Fig.12

### 7.1 Wiring Diagram MSC - 10

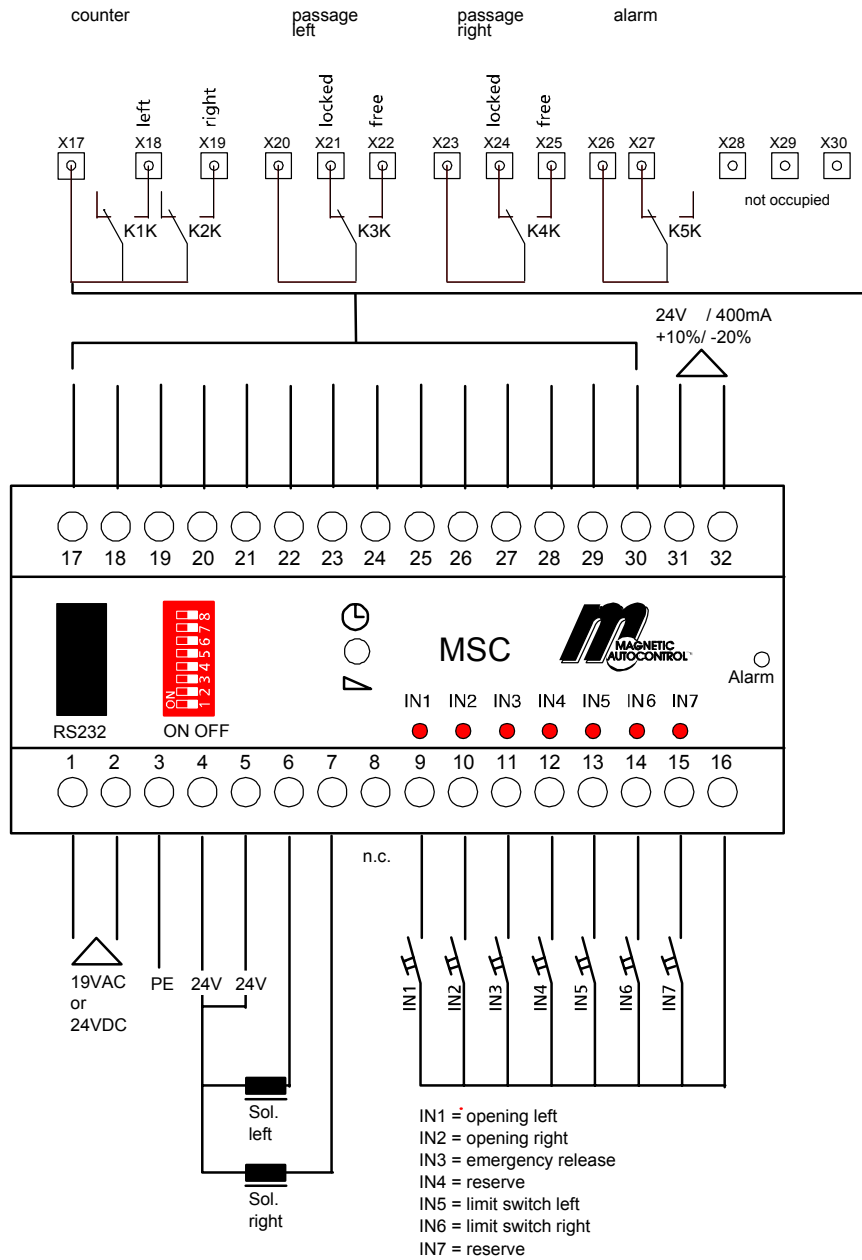

FIG.13

## 8. Housings / Access Control Panels



*Fig. 14*

Fig. 14 shows the provided access control panel.

Fig. 15 Rear view of the access control panel



The control wiring from the access control device can be fed through the tubing by drilling a hole in the shown position.

*Fig. 15*



**Warning:**

Any electrical wiring shall only be performed by a certified electrician and must conform with existing local codes and in accordance with this operating manual.



## 9. Commissioning

Once all electrical and mechanical installation have been completed and checked for errors, the turnstile can be set into service.

Check before start-up that all assembly and installation instructions have been followed and the electrical connections have been performed correctly.

### Operation of the Turnstile

The Turnstile is generally operated by an access control system or control switches.

## 10. Technical Support

Should problems occur please contact an authorized after sales service representative.

Please refer to the nameplate on the turnstile housing for the data required in the case of queries.

## 11. Spare parts and accessories

See Figure 16 for the exploded drawing, which details the individual parts and their identification numbers.



### **12. Warranty**

www.TURNSTILES.us provides a limited warranty on its turnstiles that covers all mechanical and electrical components, but excludes parts subject to wear and tear, for a period of two years from the date of first use or for a maximum of three years from the date on which the system was delivered provided that the operating instructions have been complied with, no unauthorized servicing of machine components has taken place, and that no mechanical damage to the machines is evident.

Please refer to our standard Warranty Statement.

## 13. Control Unit MSC 10

### Functions

#### 13.1 Functions of digital inputs

Input 1 terminals X21 / X22 = Opening of passage direction left  
Opening pulse passage left (entry).

Input 2 terminals X24 / X 25 = Opening of passage direction right  
Opening pulse passage right (exit)

Input 3 IN3, terminal 11 = input emergency situation  
In case of emergency passage free in both directions.

#### 13.2 Function of semi conductor outputs

Output 1 terminal X6 = solenoid left

Output 2 terminal X7 = solenoid right

Output 3 terminal X8 = reserve

#### 13.3 Function of relay outputs

Relay 1 = counter pulse left terminal X18

If the end position in passage direction left is reached a counter pulse of 300 ms is given. This applies to permanent release also.

Relay 2 = counter pulse right terminal X19

If the end position in passage direction left is reached a counter pulse of 300 ms is given. This applies to permanent release also.

Relay 3 = Display passage free left terminals X22 + X21

In case of free passage left a permanent signal is given. This output can also be used to lock a pulse transmitter for passage right if passage left is given free.

Relay 4 = Display passage free right terminals X 24 + 25

In case of free passage right a permanent signal is given. This output can also be used to lock a pulse transmitter for passage left if passage right is given free.

Relay 5 = Error-/Alarm output terminal X27

In case of certain errors, a permanent signal is given as long as the error is not eliminated.

Relay 6 = Reserve

#### 13.4 Safety functions

In case of an error in the microcontroller the watchdog, function releases a hardware reset.

## 14. Adjustable parameters

The following parameters can be adjusted using the controllers DIP switches and rotary switch:

DIP	Function	OFF	ON
1	Barrier type	MPT	MPP
2	Pulse storage	Off	On = 4 pulses per direction
3	Locking delay time	Off	On = 1 sec.approx.
4	Hardware tests	*)	*)
5	Hardware tests	*)	*)
6	Solenoid left	Normal	inverted
7	Solenoid right	Normal	inverted
8	Opening duration via LEDs	No display	display

### DIP 1 Selection of barrier type

One of the following barrier types must be selected:

- MPP
- MPT

Currently, this feature is set so that both position will work with the MPT.

### DIP 2 Pulse storage

When this function is turned off the MPT allows only one opening pulse at a time. Meaning, after each opening pulse the patron has to walk through the turnstile or the opening time has to elapse in order for the unit to accept the next signal. If turned on the unit stores the opening signals (up to 4 per direction) and the MPT decrements the counts after each turn. Therefore, a faster throughput can be achieved.

### DIP 3 Locking delay time

In order to avoid a rotation of more than 120° in case of permanent release or several stored pulses a locking delay time can be activated via a dipswitch. The turnstile is then locked for 1 sec. after each 120° rotation (one person goes through) and will then be released for the next transaction.

### DIP 6 Solenoids

Via DIP 6 and DIP 7 the function of both solenoids can be inverted separately for both directions. This depends on whether the turnstile is set up as open or closed when power fails. DIP 6 change the left solenoid output and DIP 7 the right one.

### **15 Operating modes**

- 14.1 Pulse operation in both directions without pulse storage
- 14.2 Pulse operation in both directions with pulse storage
- 14.3 Permanent release in both directions
- 14.4 Pulse operation in one direction, permanent release in the other direction

#### **Certification**

Recommendation 89/392/EWG of 14.06.89 incl. modifications up to 93/68/EWG of 22.07.03

Recommendation 73/23/EWG of 19.02.73 incl. modifications up to 93/68/EWG of 22.07.03

Recommendation 89/336/EWG of 03.05.89 incl. modifications up to 93/68/EWG of 22.07.03

DIN VDE 0113 T1 06.93 (EN 60204-1-1992, IEC 204-1-1992)

DIN EN 292 T2 11.91