

Turnstile Canopy Substructural Parts Specification

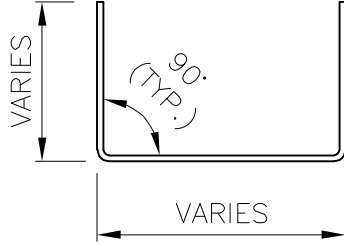

ROLL-FORMED CHANNEL

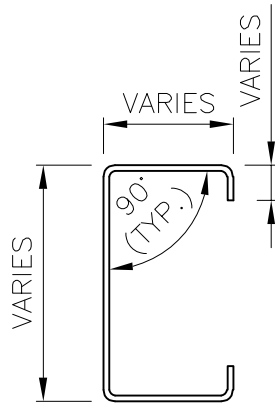

ROLL-FORMED CEE

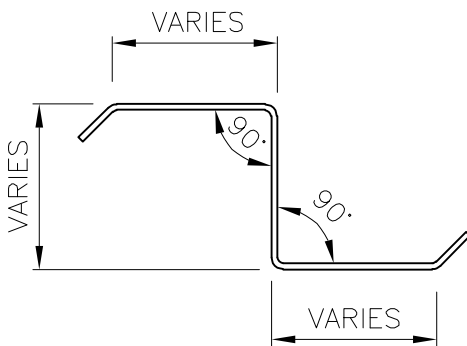

ROLL-FORMED ZEE

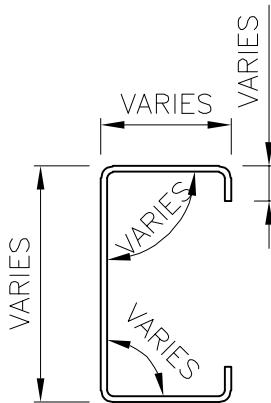

ROLL-FORMED EAVE STRUTS

Material

ASTM A653 (55ksi) - 10, 12, 14 & 16 GA. Galvanized Steel
 ASTM A1011 (55ksi) - 12, 14 & 16 GA. Red Primed Steel

Minimum Length: 5'-0"

Maximum Length: 45'-0"

Min. / Max. Lengths do vary by Plant. Please contact TURNSTILES.us for more information on lengths.

Finishes

Galvanized

Red primed and painted with your choice of color

Manufacturing

Roll-Formed

NOTE:

All data represented on this sheet may not be applicable to all widths and gauges. Please contact TURNSTILES.us for more information.

Turnstile Canopy Substructural Parts Specification (continued)

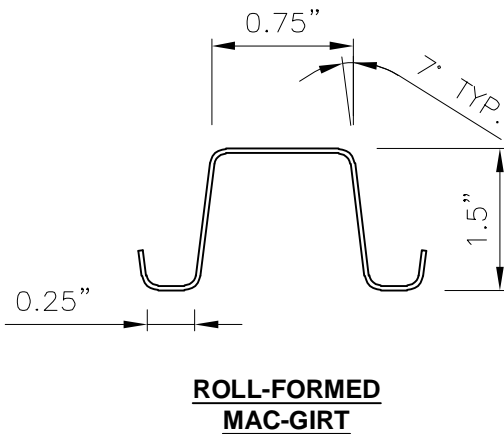
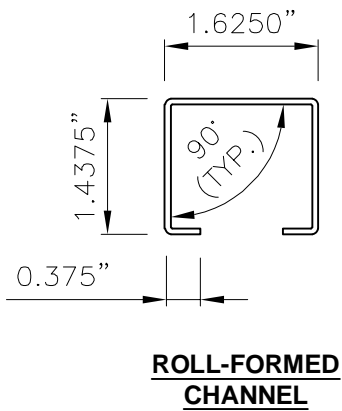
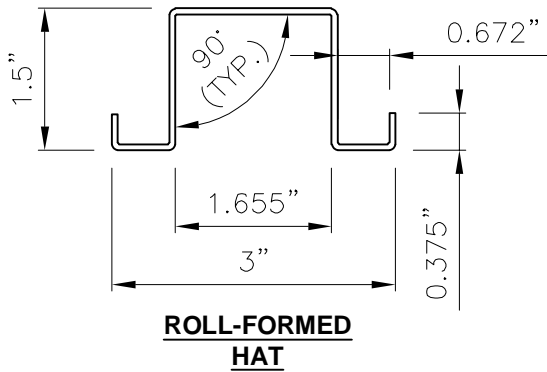

Material
 ASTM A653 (55ksi) - 16, 18 & 20 GA. Galvanized Steel
 Minimum Length: 10'-0"
 Maximum Length: 24'-0"

Finishes
 Galvanized G90 - 16 GA.
 Galvanized G40 - 18 & 20 GA.

Manufacturing
 Roll-Formed

NOTE:
 All data represented on this sheet may not be applicable to all widths and gauges.
 Please contact TURNSTILES.us for more information.

