

## PRODUCT MANUAL



## FULL HEIGHT TURNSTILES

CONTENTS

**1. COPYRIGHT ..... 5**

**2. PRODUCT BRIEF ..... 5**

**3. GENERAL DRAWINGS ..... 6**

Figure 1: 3-Arm TITAN Single Turnstile ..... 6

Figure 2: 4-Arm TITAN Single Turnstile ..... 7

Figure 3: 3-Arm TITAN Double Turnstile ..... 8

Figure 4: 4-Arm TITAN Double Turnstile ..... 9

Figure 5: 3-Arm TRIUMPH Single Turnstile ..... 10

Figure 6: 4-Arm TRIUMPH Single Turnstile ..... 11

Figure 7: 3-Arm TRIUMPH Double Turnstile ..... 12

Figure 8: 4-Arm TRIUMPH Double Turnstile ..... 13

Figure 9: 5-Arm TRIUMPH Single Turnstile ..... 14

Figure 10: 5-Arm TRIUMPH Double Turnstile ..... 15

**4. SINGLE TURNSTILE FRAME ASSEMBLY ..... 16**

Figure 11: 3-arm Turnstile Assembly ..... 18

Figure 12: 4-arm Turnstile Assembly ..... 19

Figure 13: Single turnstile assembly ..... 20

**5. DOUBLE TURNSTILE FRAME ASSEMBLY ..... 21**

Figure 14: 3-arm Double Turnstile Assembly ..... 23

Figure 15: 4-arm Double Turnstile Assembly ..... 24

Figure 16: Double Assembly Details ..... 25

Figure 17: Double turnstile assembly ..... 26

Figure 18: Double Comb Assembly ..... 27

Figure 19: Double Comb Fixing to Channel ..... 27

**6. ROTOR ASSEMBLY** ..... 28

Figure 20: Rotor Assembly Details..... 28

**7. CARD READER CHANNEL MOUNTING & DRAW WIRES** ..... 30

Figure 21: Card Reader Mounting Channel & Draw Wire..... 30

**8. FURTHER ROTOR ASSEMBLY INFORMATION** ..... 31

Figure 22: Views on Top Disk & Base Bearing ..... 32

**9. INSTALLATION** ..... 33

Figure 23: Isometric view on plinth and conduits provision ..... 33

**10. CONTROL PANEL & LOGIC**..... 35

Figure 24: Turnstile control panel components..... 35

**11. TURNSTILE LOGIC TYPES**..... 36

Figure 25: Grey Plug-in Logic (TURTL373) ..... 36

Figure 26: Base of Grey Plug-in Logic (TURTL373) ..... 37

Table 1: TURTL373 Logic Dipswitch Settings ..... 37

Figure 27: Blue Plug-in Logic (TL300TUR) ..... 38

Table 2: TL300TUR Logic Dipswitch Settings ..... 38

**12. WIRING DIAGRAMS**..... 39

Figure 28: Wiring Diagram for Full Height Turnstile ..... 39

Figure 29: Wiring Diagram for FH Turnstile with Battery Backup ..... 40

**13. STANDARD FACTORY SETUP** ..... 41

**14. FIRE ALARM SET-UP** ..... 42

**15. FAIL-SECURE AND FAIL-SAFE** ..... 42

Figure 30: Solenoid in Fail-secure arrangement..... 42

Figure 31: Solenoid in Fail-safe arrangement ..... 43

Figure 32: Solenoid assembly – Fail-secure..... 44

..... 45

---

Figure 33: Solenoid assembly – Fail-safe ..... 45

**16. MAINTENANCE** ..... 46

Table 3: Recommended Maintenance Procedure ..... 46

**17. CLEANING**..... 47

Table 4: Recommended Cleaning Frequency..... 47

**18. SPARE PARTS** ..... 48

Table 5: Spare Parts List ..... 48

**19. FAULT FINDING** ..... 49

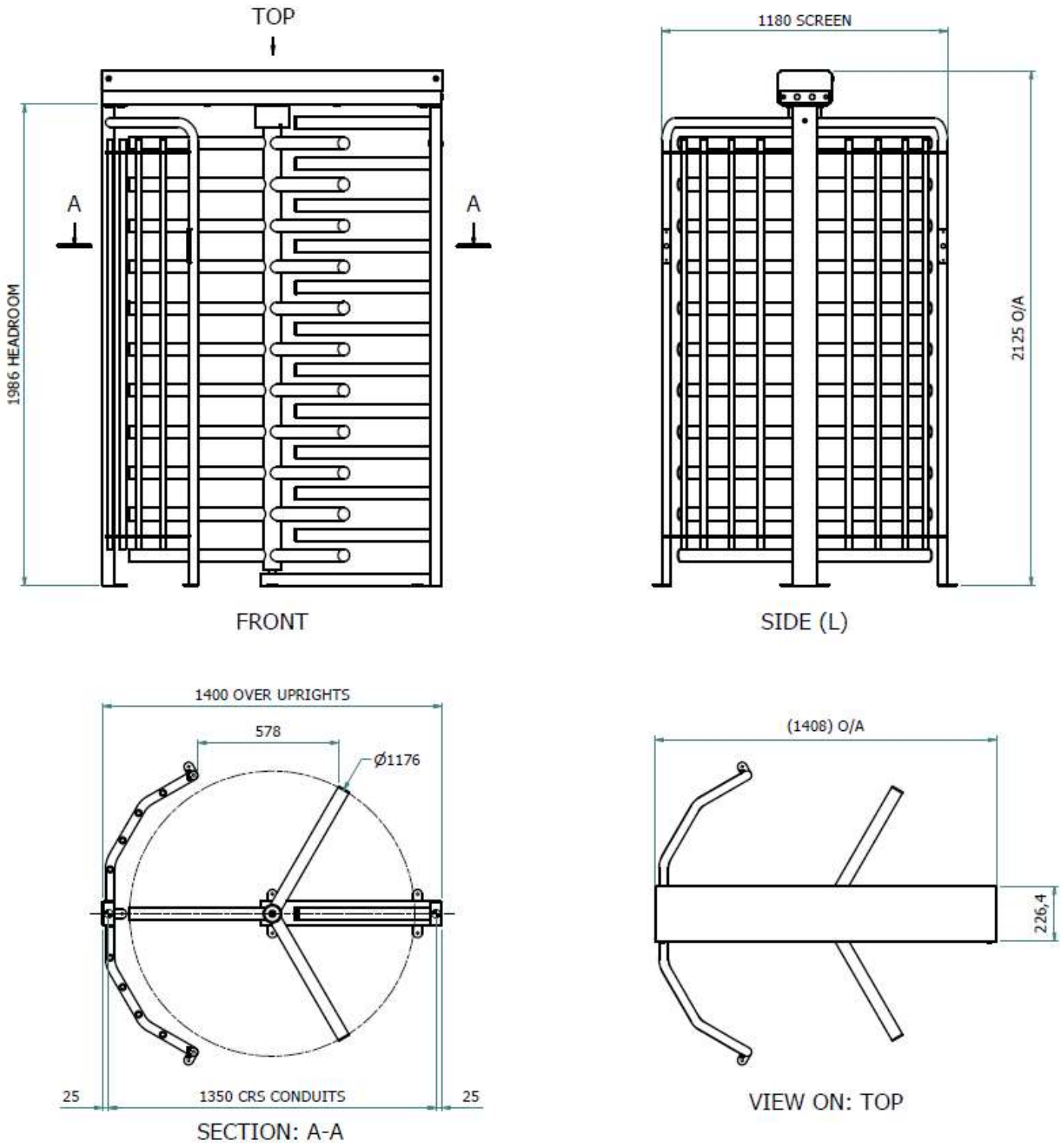
## **1. COPYRIGHT**

- 1.1. No part of this module may be reproduced in any form, photocopy or otherwise, without the written permission of Turnstar systems. All information, drawings and diagrams may not be made public or shared with a third party.
- 1.2. In the event of any breach of abovementioned copyright, the rights of Turnstar systems will be strictly enforced.
- 1.3. The information contained herein remains the intellectual property of Turnstar systems.

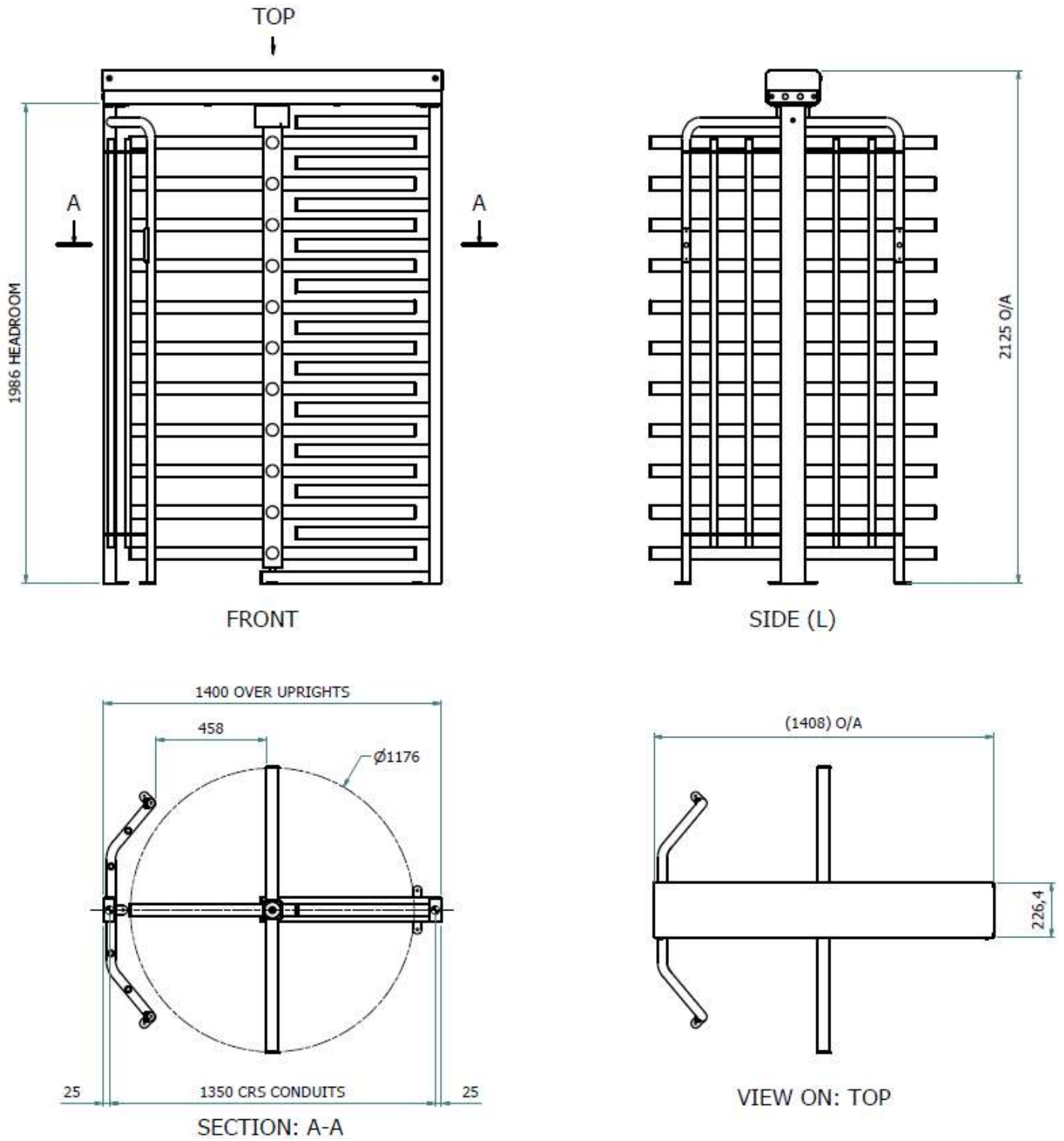
## **2. PRODUCT BRIEF**

- 2.1. The Full Height Turnstile is a high security access control product
- 2.2. The Turnstile is fitted with a heavy heavy-duty mechanism and controller, which controls the overall functioning of the turnstile.
- 2.3. The Turnstile can be bi-directional entry and exit, one person at a time.
- 2.4. Two models are available. The TRIUMPH and the TITAN.
- 2.5. The TITAN is available in 3-arm and 4-arm configurations.
- 2.6. The TRIUMPH is available in 3-arm, 4-arm, and 5-arm configurations.
- 2.7. The FH Turnstile can be supplied in either double or single configuration.
- 2.8. The Turnstile requires a trigger for either entry or exit direction, typically provided by an access control system.
- 2.9. The Turnstile is available in a number of different finishes, including powder coated mild steel, hot dip galvanised mild steel or 304/ 316 grade brushed stainless steel.

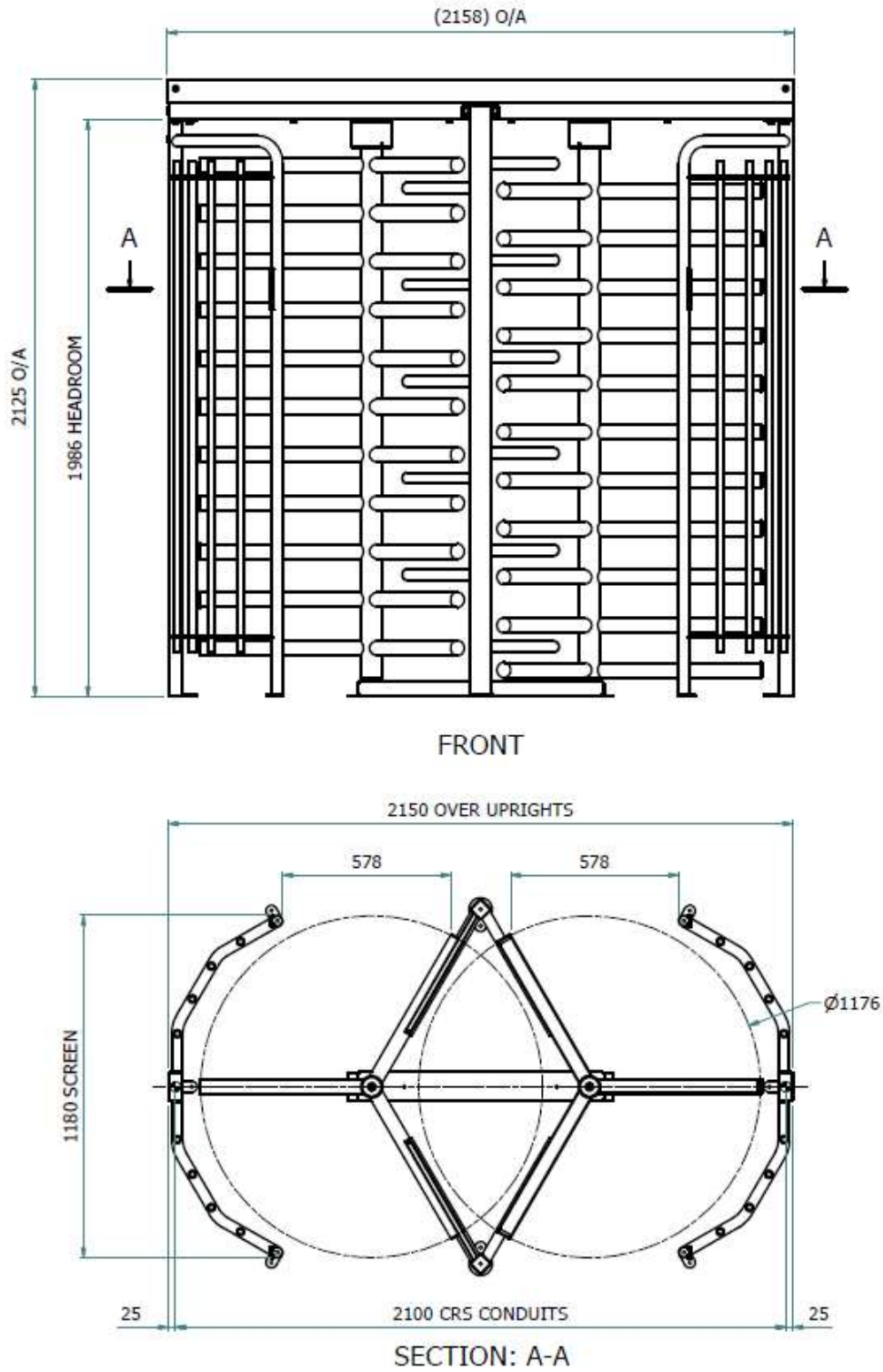
### 3. GENERAL DRAWINGS



**Figure 1: 3-Arm TITAN Single Turnstile**

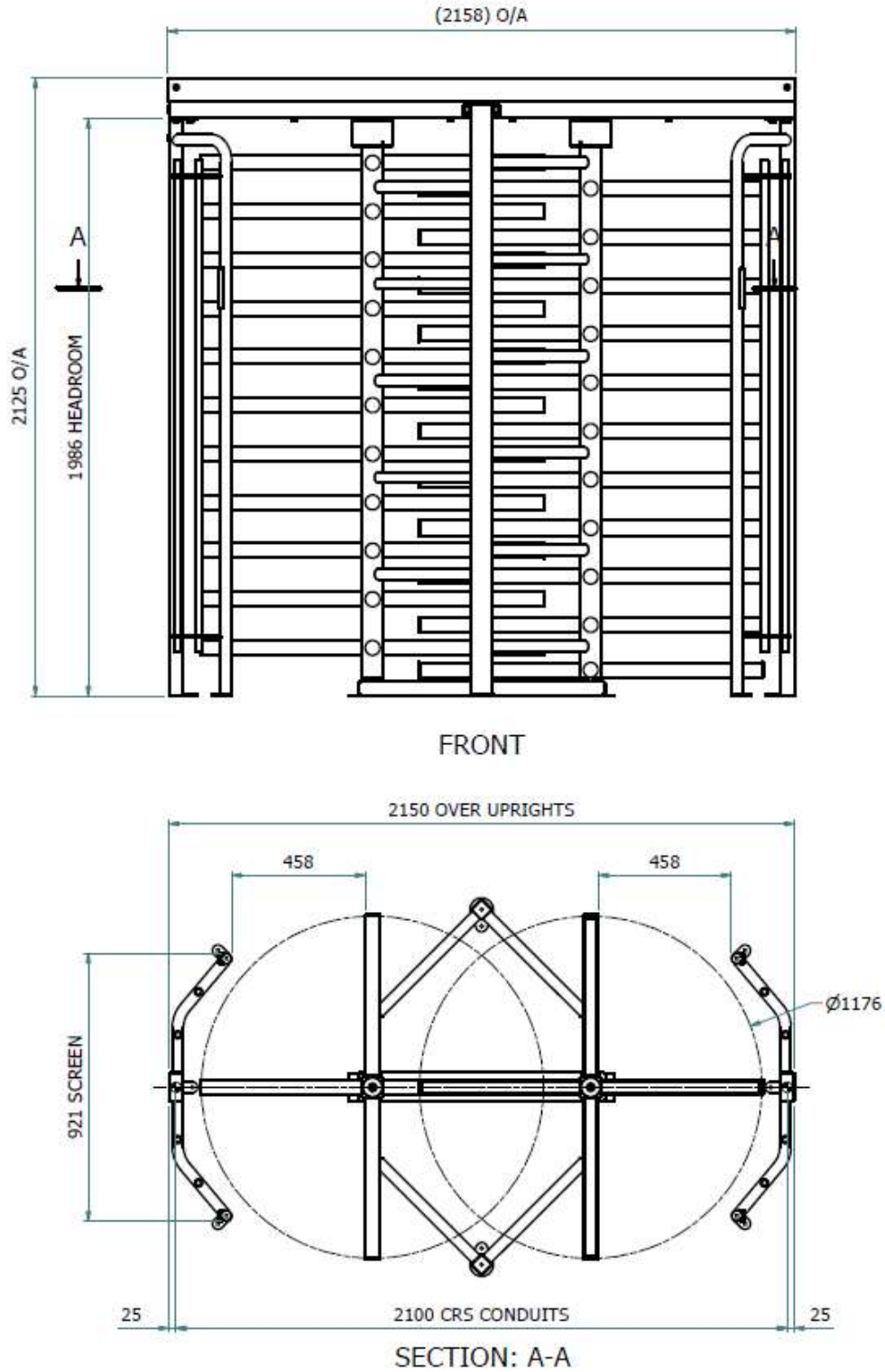


**Figure 2: 4-Arm TITAN Single Turnstile**

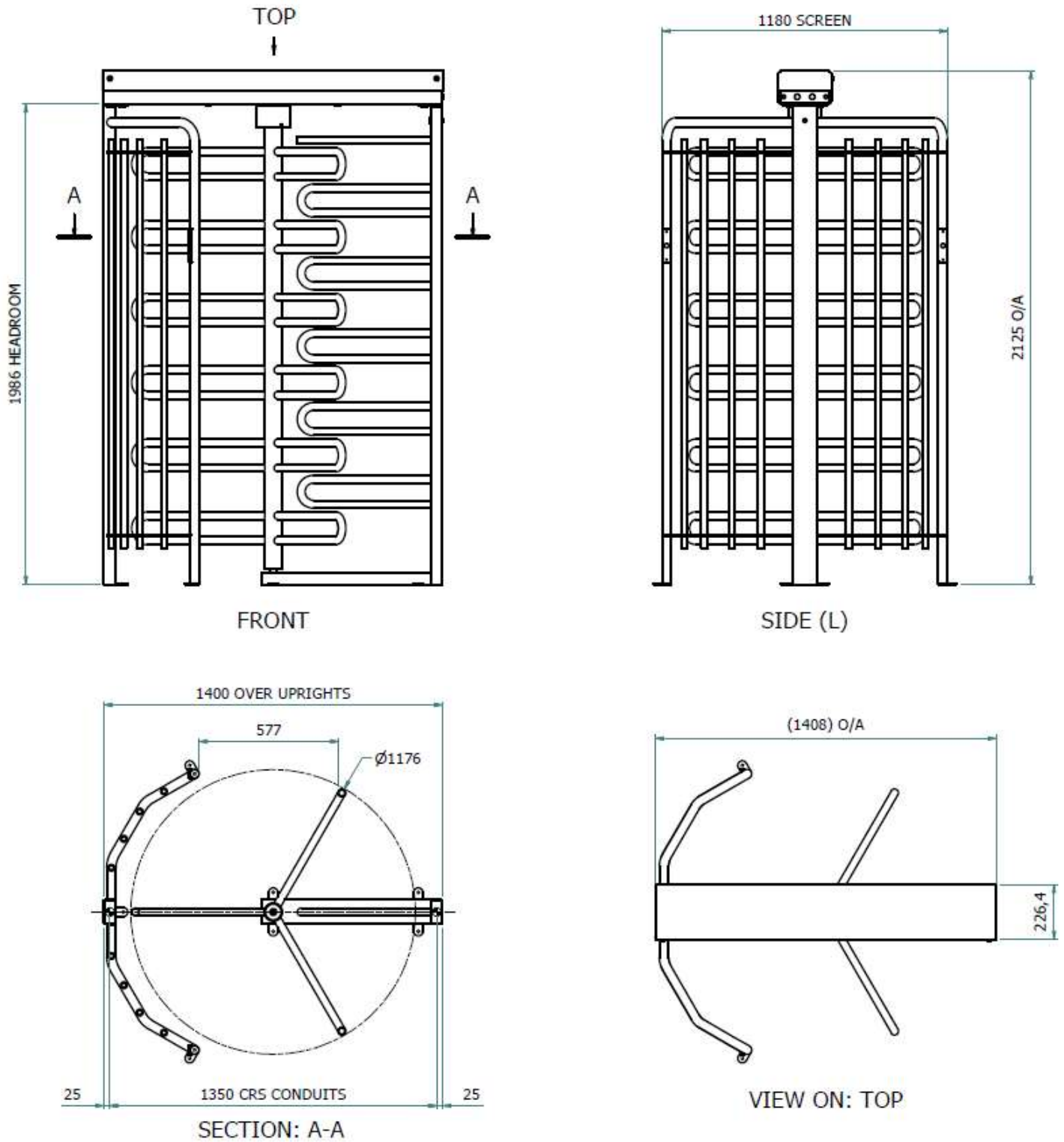


**Figure 3: 3-Arm TITAN Double Turnstile**

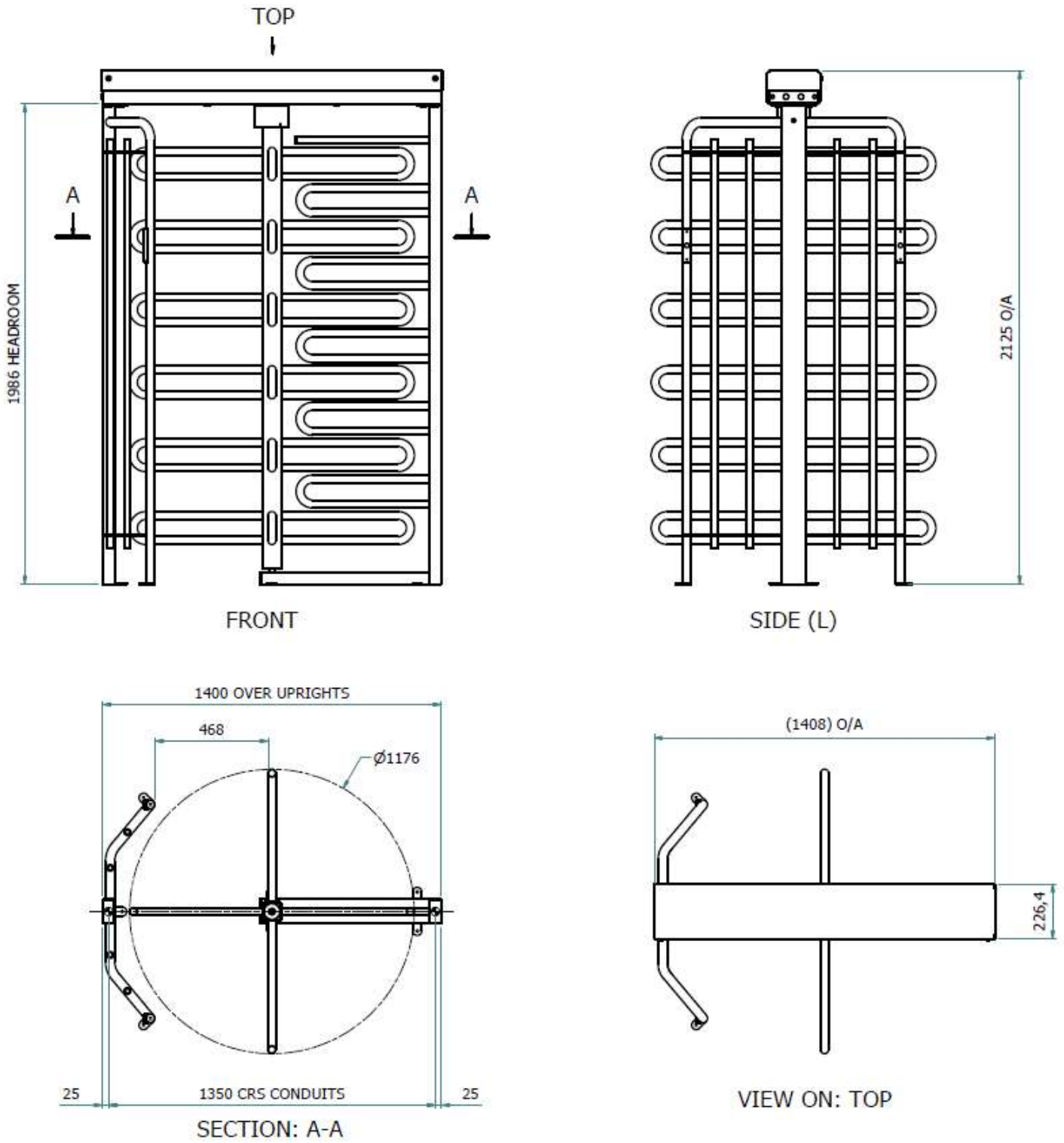




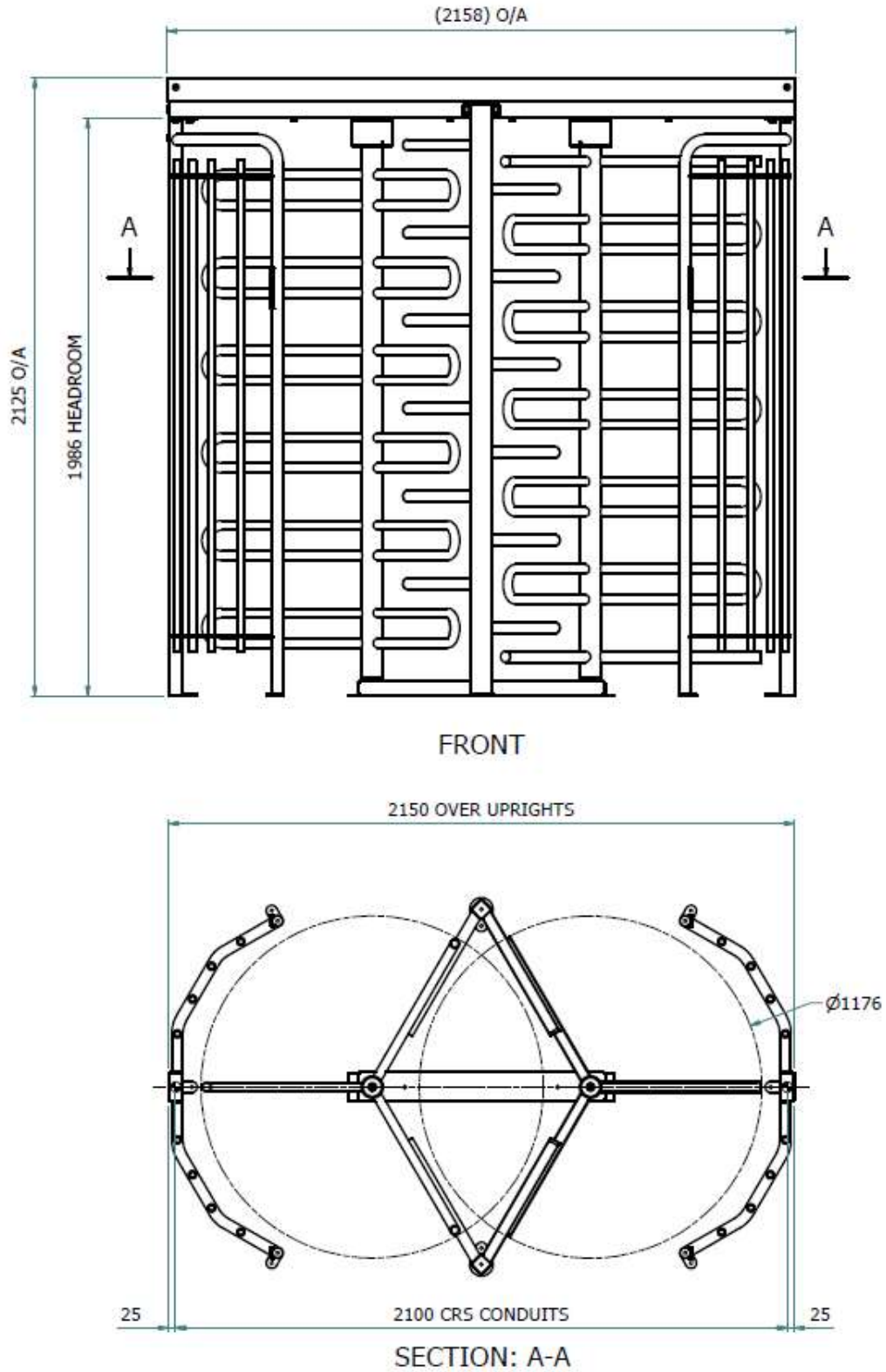
**Figure 4: 4-Arm TITAN Double Turnstile**



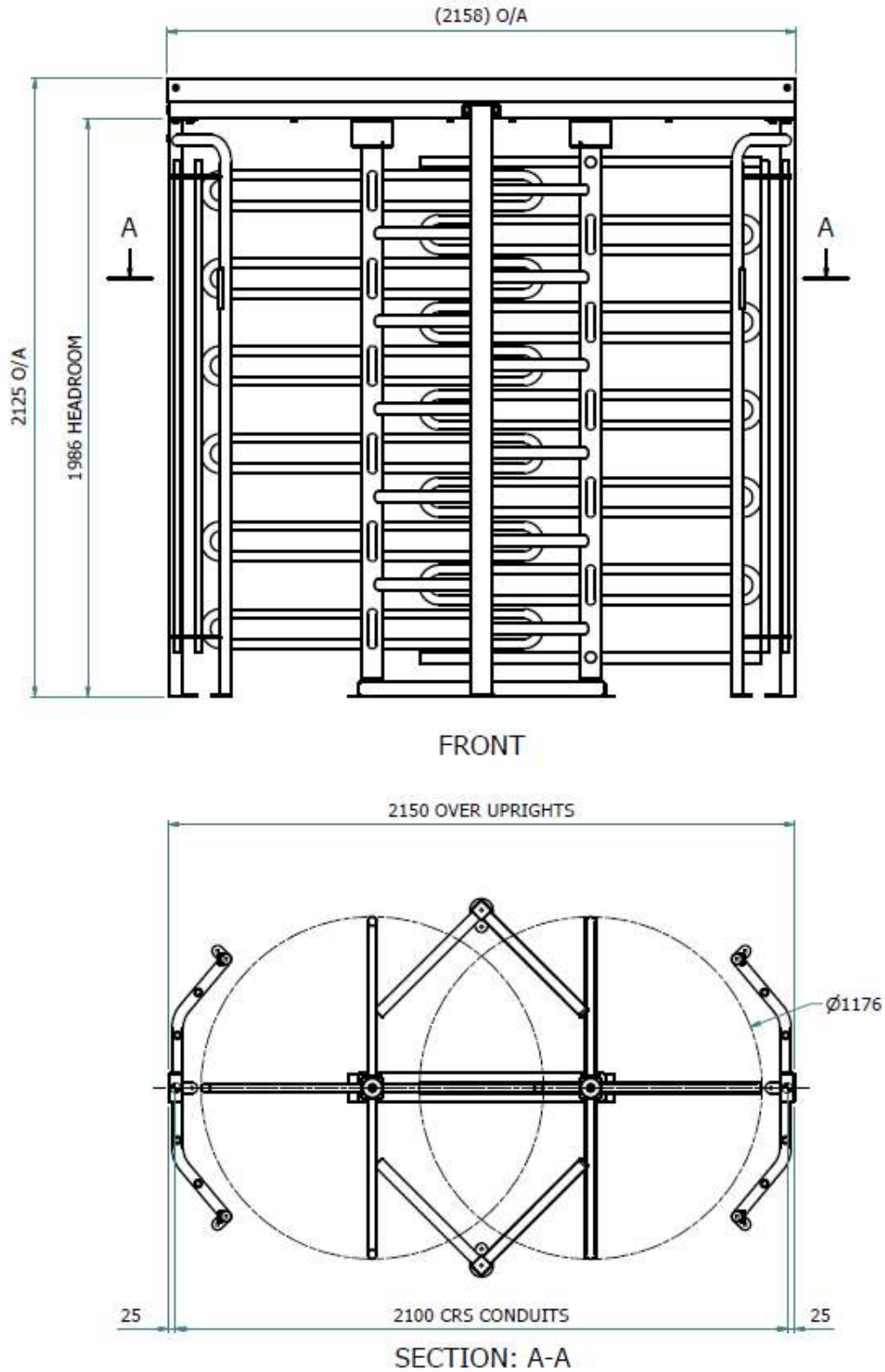
**Figure 5: 3-Arm TRIUMPH Single Turnstile**



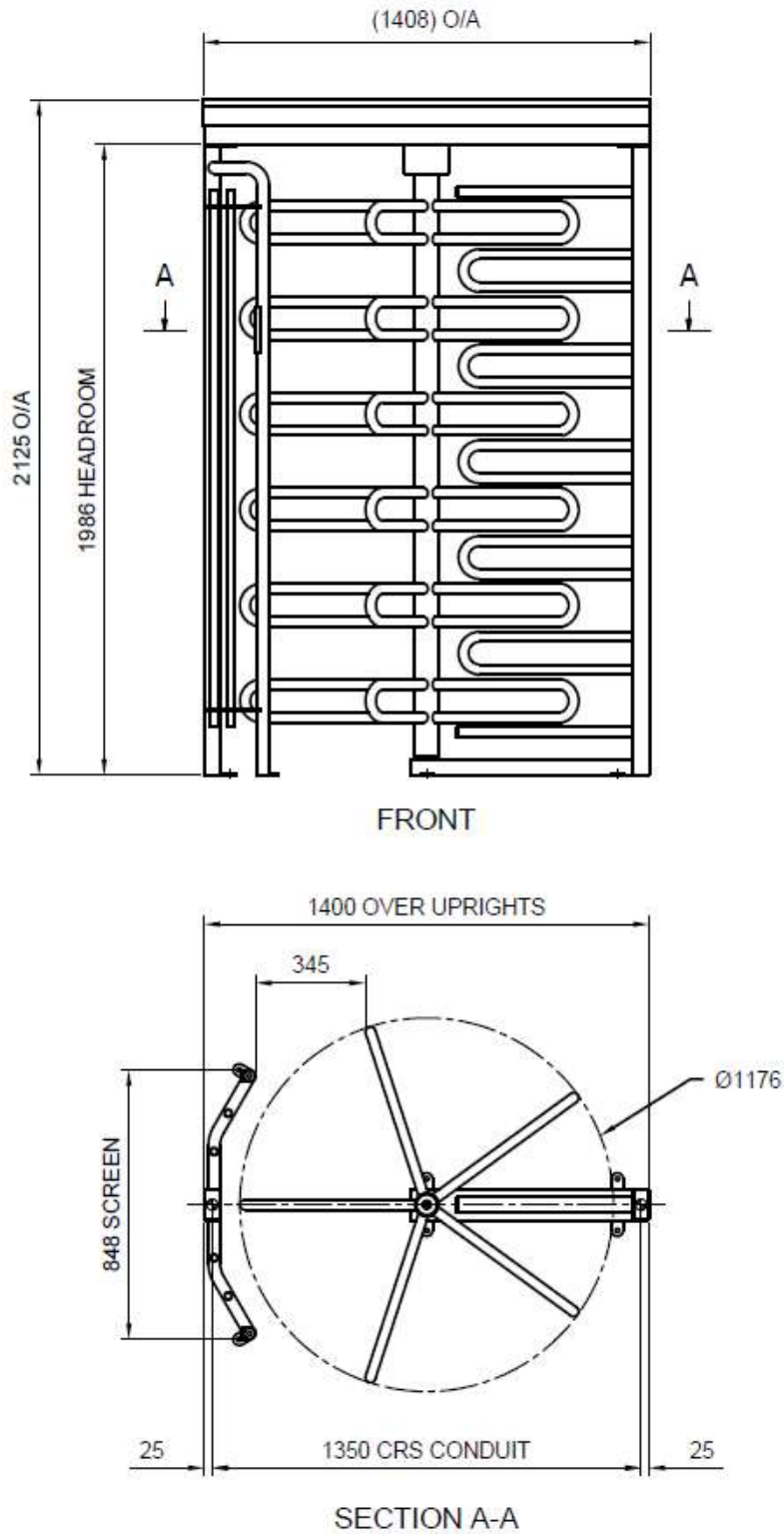
**Figure 6: 4-Arm TRIUMPH Single Turnstile**



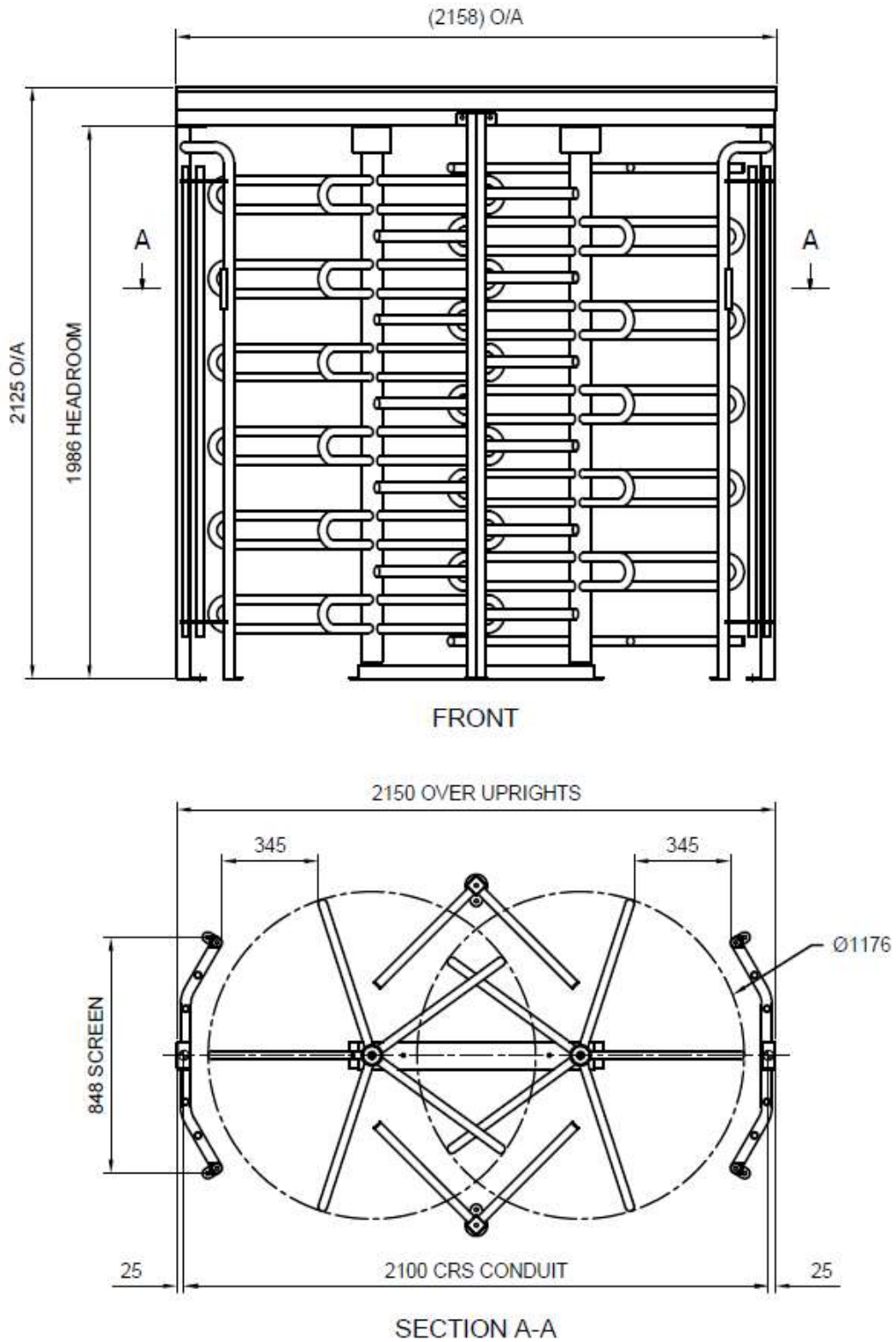
**Figure 7: 3-Arm TRIUMPH Double Turnstile**



**Figure 8: 4-Arm TRIUMPH Double Turnstile**



**Figure 9: 5-Arm TRIUMPH Single Turnstile**



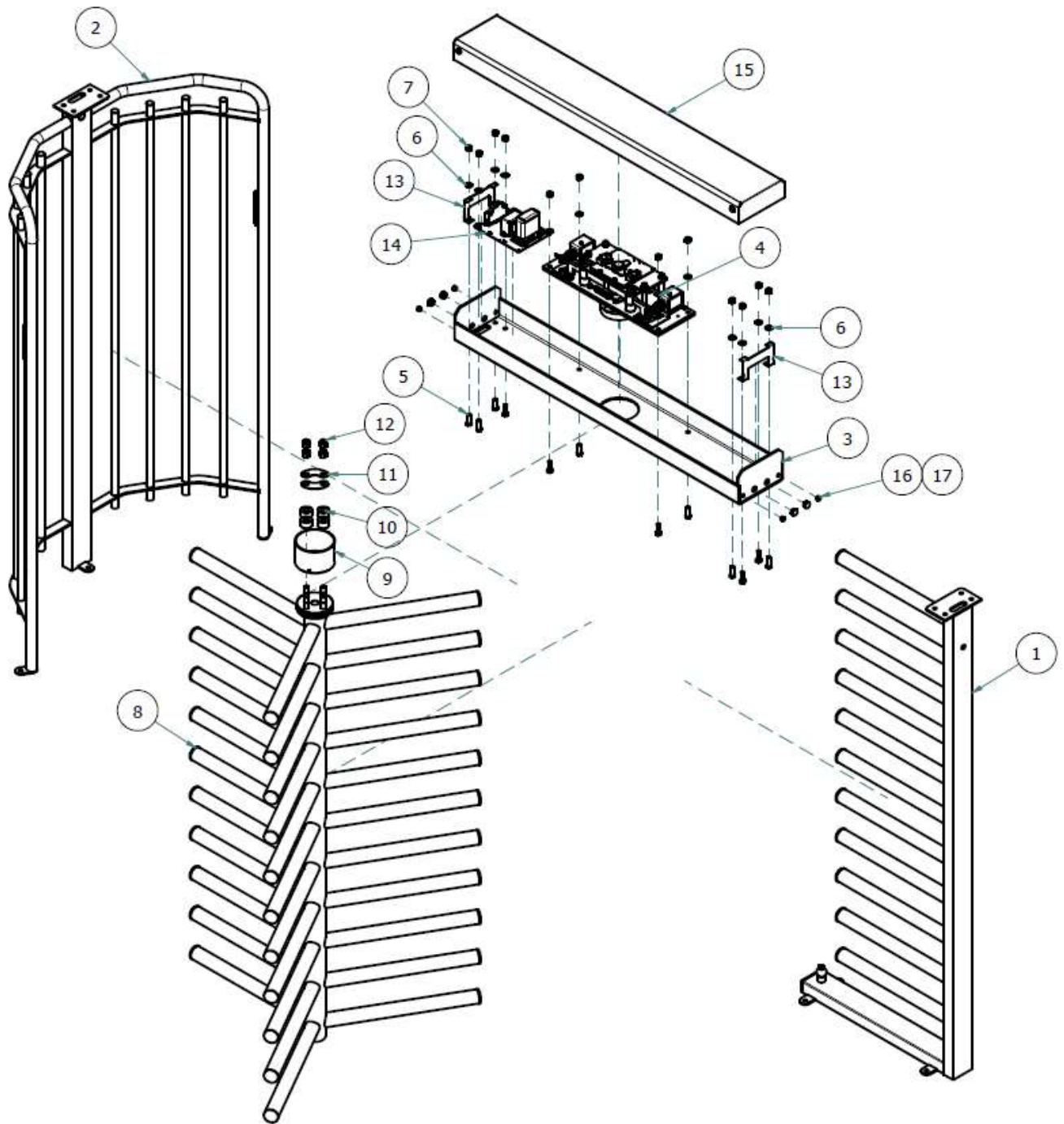
**Figure 10: 5-Arm TRIUMPH Double Turnstile**

## **4. SINGLE TURNSTILE FRAME ASSEMBLY**

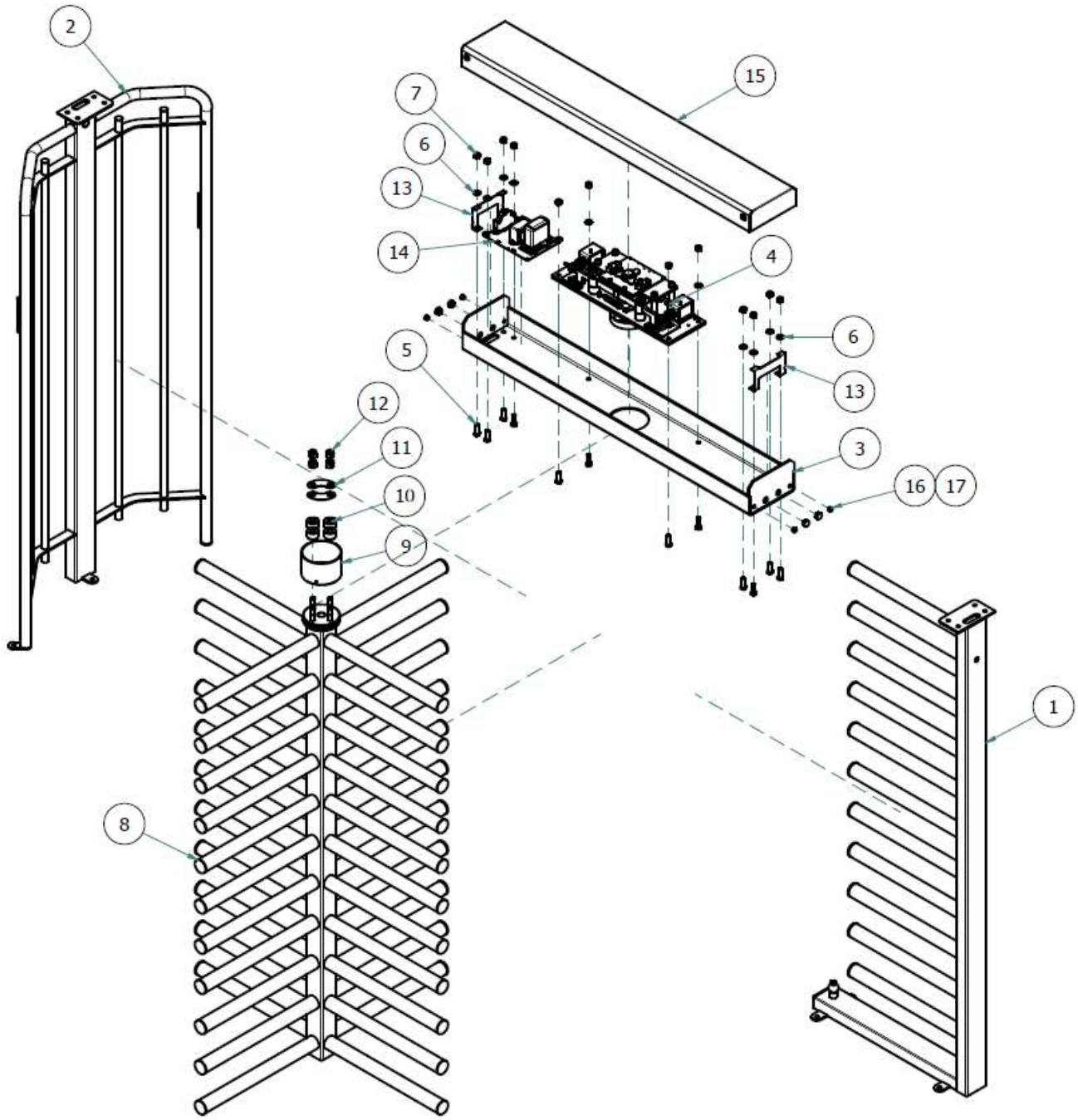
- 4.1. The assembly and installation of the product can be done by two people.
- 4.2. Tools required for assembly:
- Step ladder
  - 5m Measuring tape
  - Marker pen/chalk
  - Chalk line
  - Hammer drill
  - 16mm masonry drill bit
  - M10 x 75mm coach bolts with nylon plug (9x for a single turnstile, 10x for a double turnstile)
  - Hammer
  - Spirit level
  - 19mm flat spanner
  - 24mm flat spanner
  - Size 3 allen head key
  - 8 Allen Head Key for M10 (Pawls, Top Plate)
- 4.3. Tools for servicing solenoid
- 7 Spanner for M4 Hexnut
  - 10 Spanner for M6 hex bolt
  - 5 Allen Head Key for M6
  - Flat Screwdriver for M5 Screws
- 4.4. Ensure that there is a level surface of 1430mm long x 1430mm wide to place the turnstile on.
- 4.5. Place the screen and comb upright, ensuring the outside verticals are 1400mm apart.
- 4.6. Place the top channel on top of the screen and comb. Ensure that the override locks are on the desired side for ease of access.
- 4.7. Bolt the top channel to the screen and comb using the M12 bolts and hexnuts. Ensure that the top cover locking plates and control channel chassis plate are also fixed during this process.



Single Turnstile Assembly Parts (For 3-arm & 4-arm)		
No	Part Description	Qty
1	Single Comb	1
2	Screen <i>(3-arm or 4-arm)</i>	1
3	Single Top Channel	1
4	Mechanism <i>(3-arm or 4-arm)</i>	1
5	M12 Bolts	12
6	12 Washers	12
7	M12 Hexnuts	12
8	Rotor <i>(3-arm or 4-arm)</i>	1
9	Disk Sleeve	1
10	Rubber Buffers	4
11	Bean Washers	2
12	M16 Nylock Hexnuts	4
13	Locking Plate	2
14	Controller	1
15	Single Top Cover	1
16	13 Panel Plug	4
17	20 Panel Plug	4

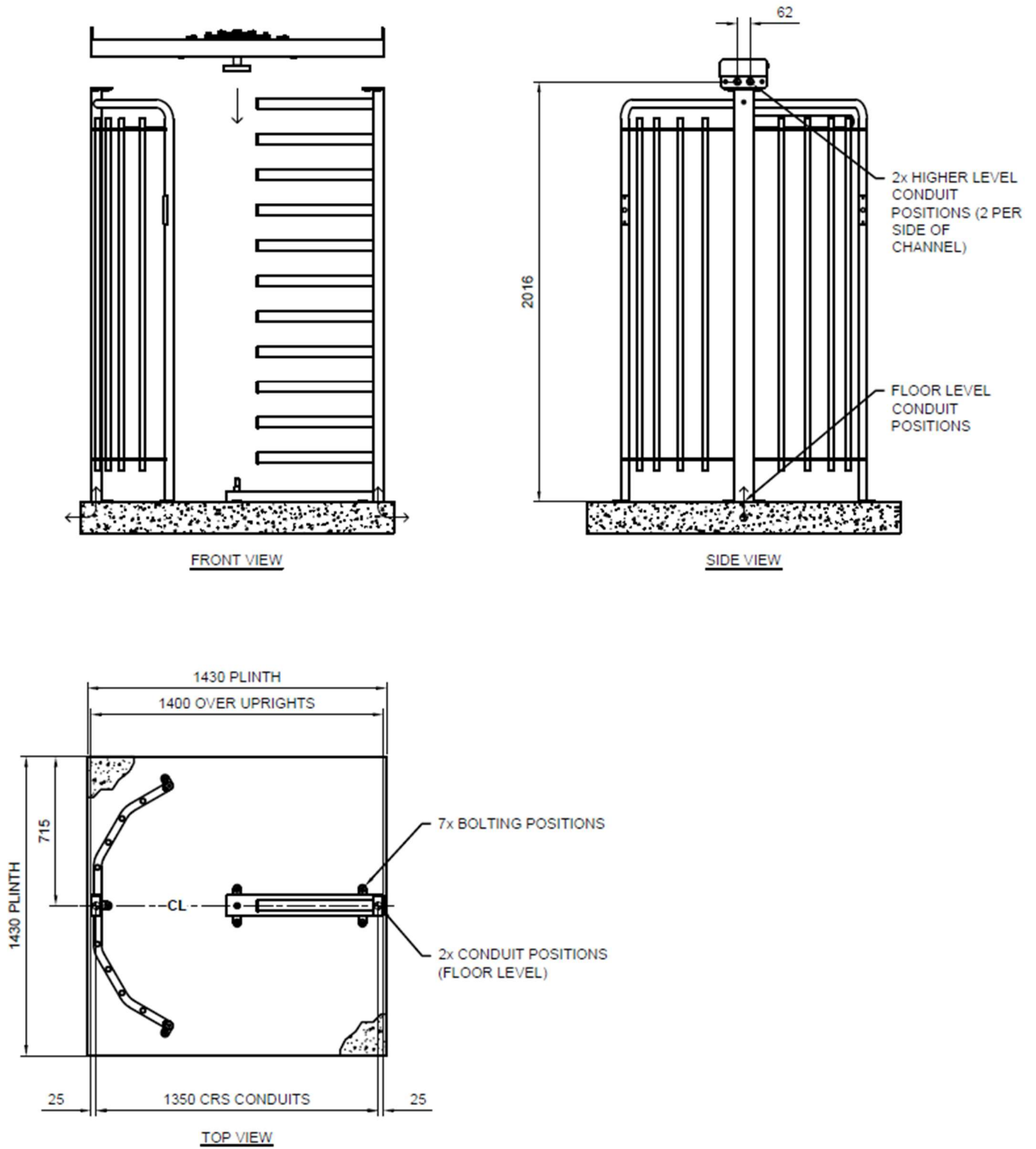


**Figure 11: 3-arm Turnstile Assembly**



**Figure 12: 4-arm Turnstile Assembly**

### **SINGLE FRAME ASSEMBLY**

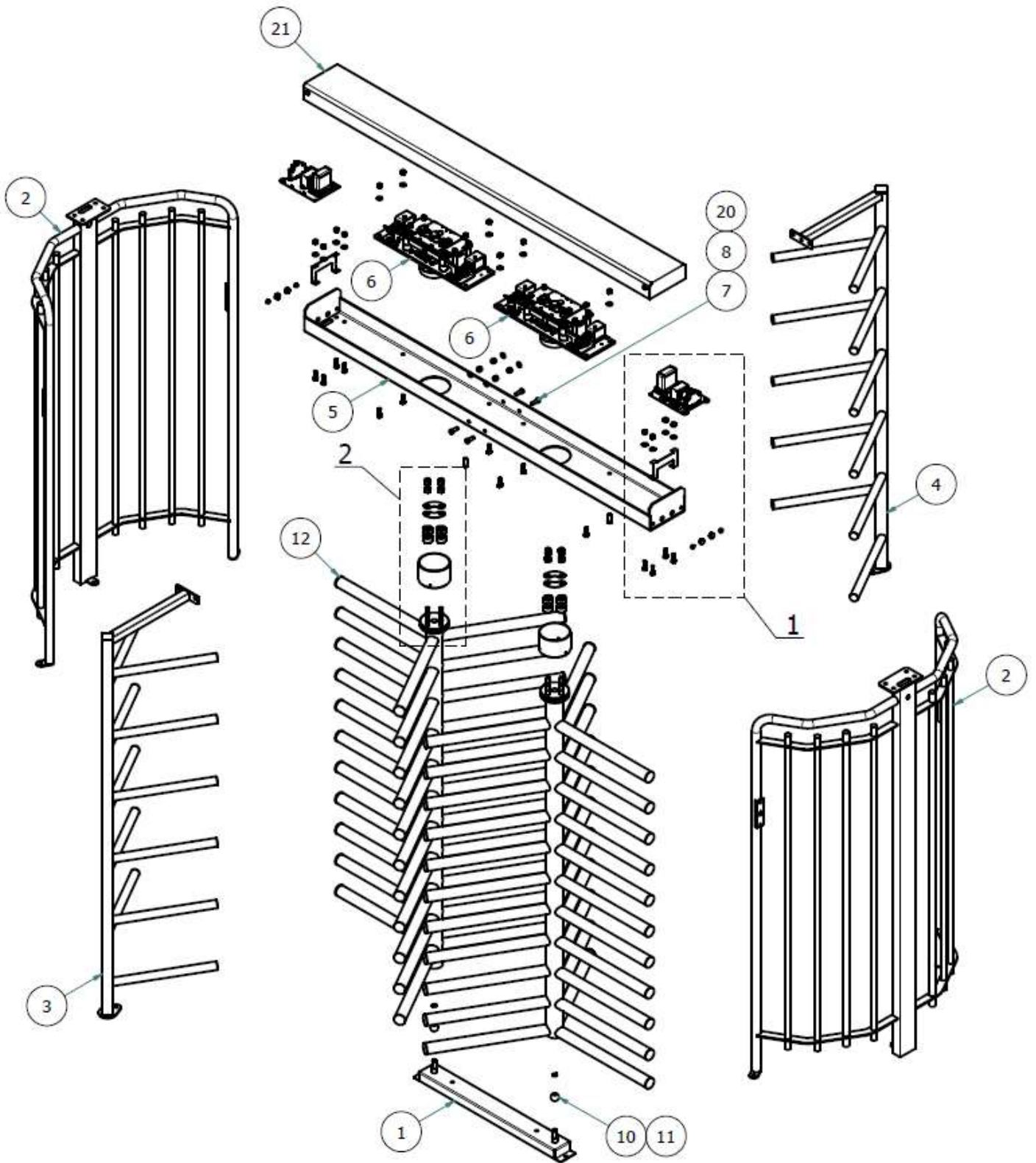


**Figure 13: Single turnstile assembly**

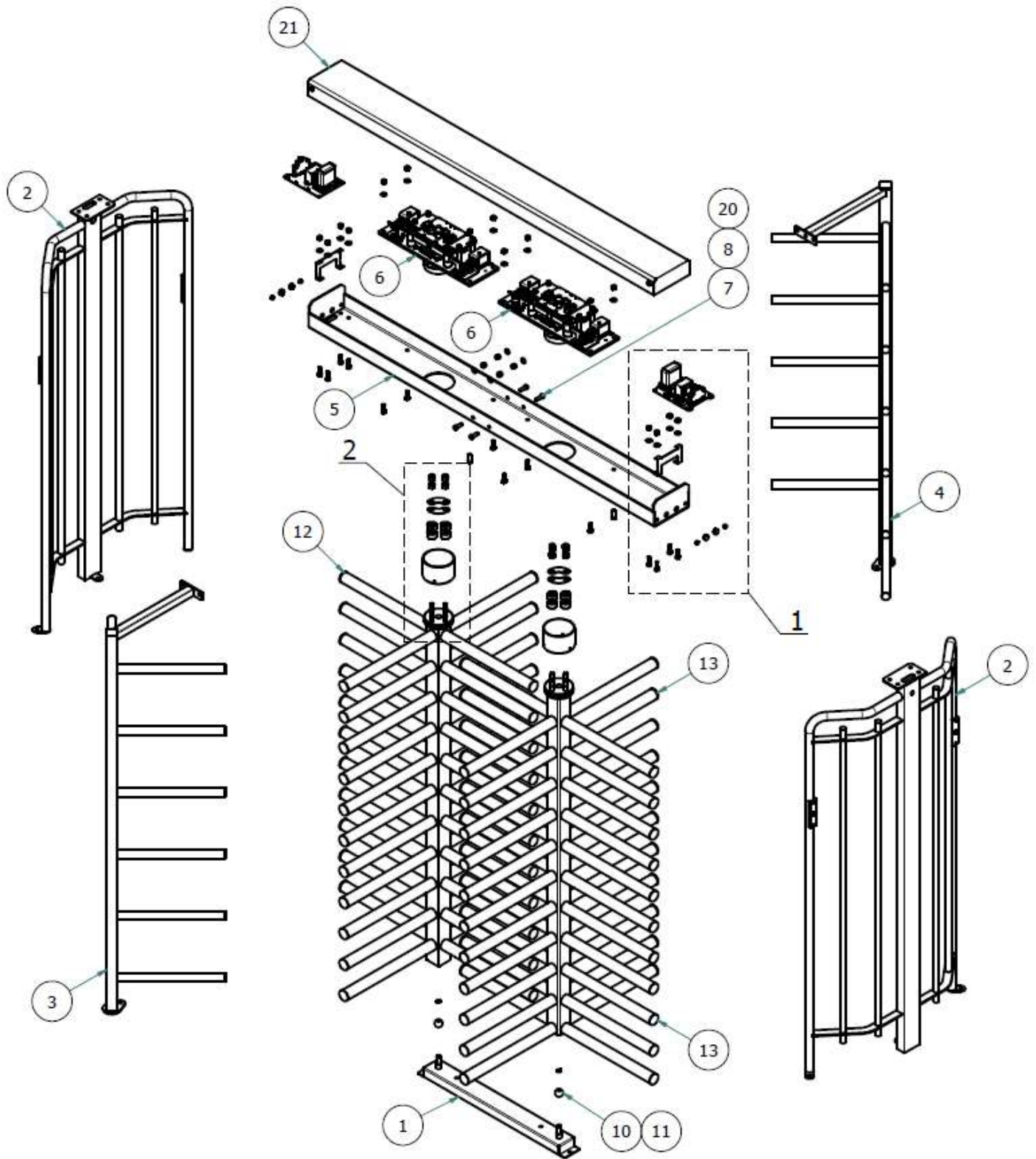
## 5. **DOUBLE TURNSTILE FRAME ASSEMBLY**

- 5.1. The assembly and installation of the product can be done by two people.
- 5.2. The double turnstile has two screens and a base channel with the bearings for the two rotors. There are two combs placed perpendicular to the top channel mounted to the floor and the top channel.
- 5.3. Tools required for assembly:
  - Step ladder
  - 5m Measuring tape
  - Marker pen/chalk
  - Chalk line
  - Hammer drill
  - 16mm masonry drill bit
  - M10 x 75mm coach bolts with nylon plug (9x for a single turnstile, 10x for a double turnstile)
  - Hammer
  - Spirit level
  - 19mm flat spanner
  - 24mm flat spanner
  - Size 3 allen head key
  - 8 Allen Head Key for M10 (Pawls, Top Plate)
- 5.4. Tools for servicing solenoid
  - 7 Spanner for M4 Hexnut
  - 10 Spanner for M6 hex bolt
  - 5 Allen Head Key for M6
  - Flat Screwdriver for M5 Screws
- 5.5. Ensure that there is a level surface of 2180mm long x 1430mm wide to place the turnstile on.
- 5.6. Place the screen and comb upright, ensuring the outside verticals are 2150mm apart.
- 5.7. Place the top channel on top of the two screens. Ensure that the override locks are on the desired side for ease of access.
- 5.8. Bolt the top channel to the screens using the M12 bolts and hexnuts. Ensure that the top cover locking plates and control channel chassis plate are also fixed during this process.

Double Turnstile Assembly Parts (For 3-arm & 4-arm)		
No	Part Description	Qty
1	Double Bearing Base Channel	1
2	Screen <i>(3-arm or 4-arm)</i>	2
3	Double Comb A <i>(3-arm or 4-arm)</i>	1
4	Double Comb B <i>(3-arm or 4-arm)</i>	1
5	Double Top Channel	1
6	Mechanism <i>(3-arm or 4-arm)</i>	2
7	M12 Bolts	16
8	12 Washers	16
9	M12 Hexnuts	16
10	Bearing Sphere	2
11	Circlip	2
12	Double Rotor A <i>(3-arm or 4-arm)</i>	1
13	Double Rotor B <i>(3-arm or 4-arm)</i>	1
14	Disk Sleeve	2
15	Rubber Buffers	8
16	Bean Washers	4
17	M16 Nylock Hexnuts	8
18	Locking Plate	2
19	Controller	2
20	M12 Nylock Hexnuts	4
21	Double Top Cover	1
22	13 Panel Plug	4
23	20 Panel Plug	4

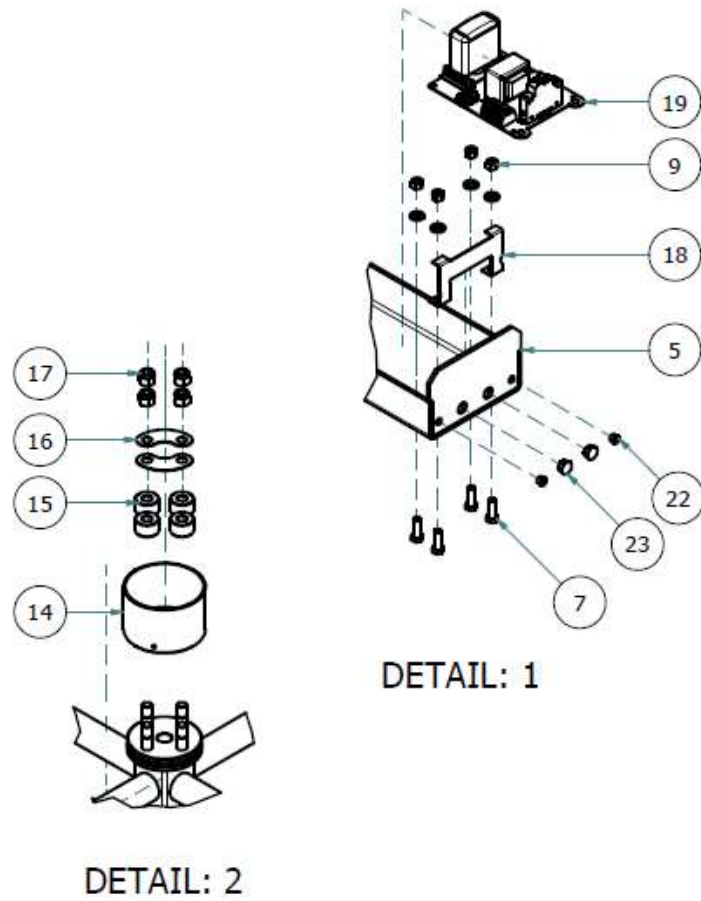


**Figure 14: 3-arm Double Turnstile Assembly**

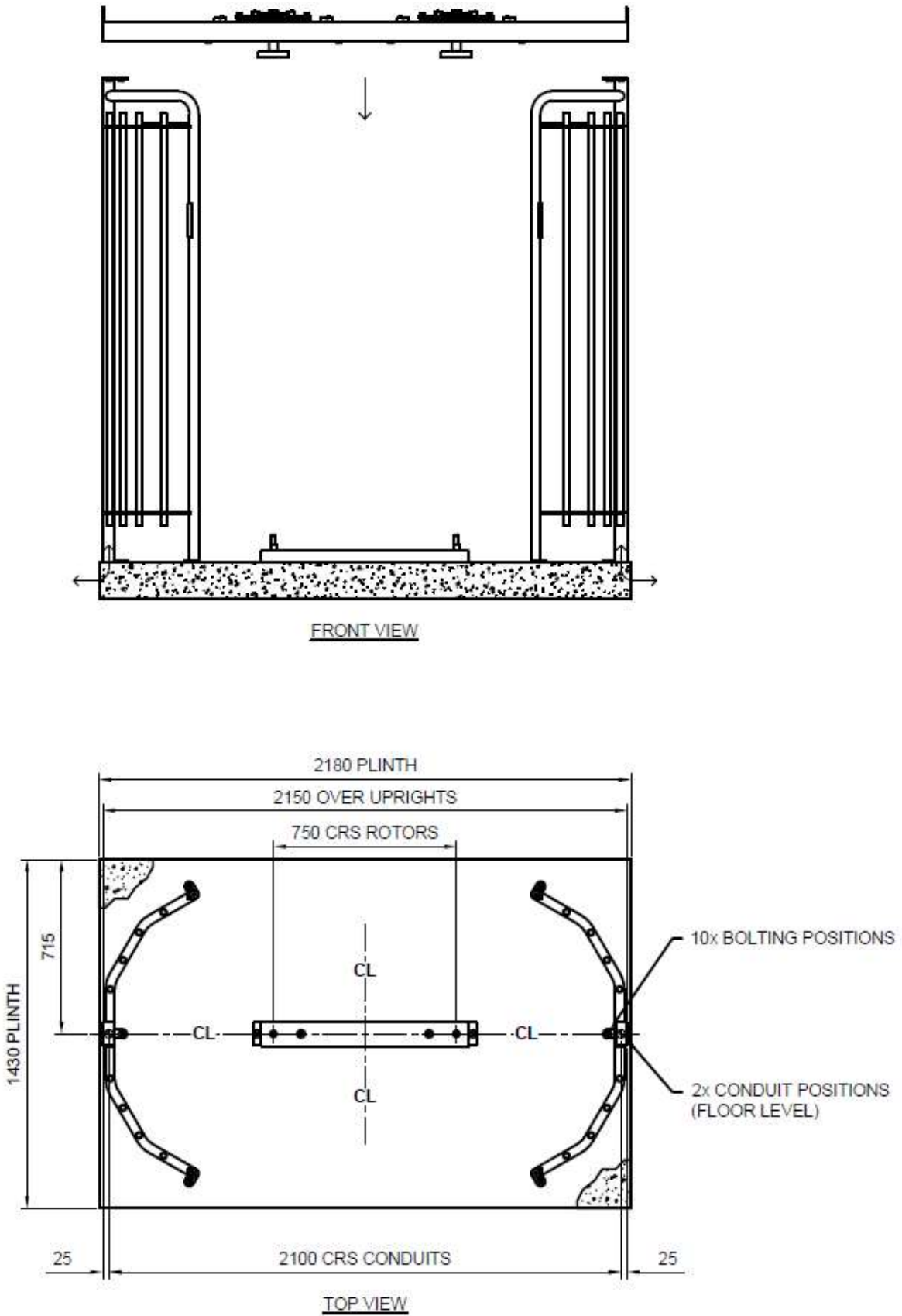


**Figure 15: 4-arm Double Turnstile Assembly**

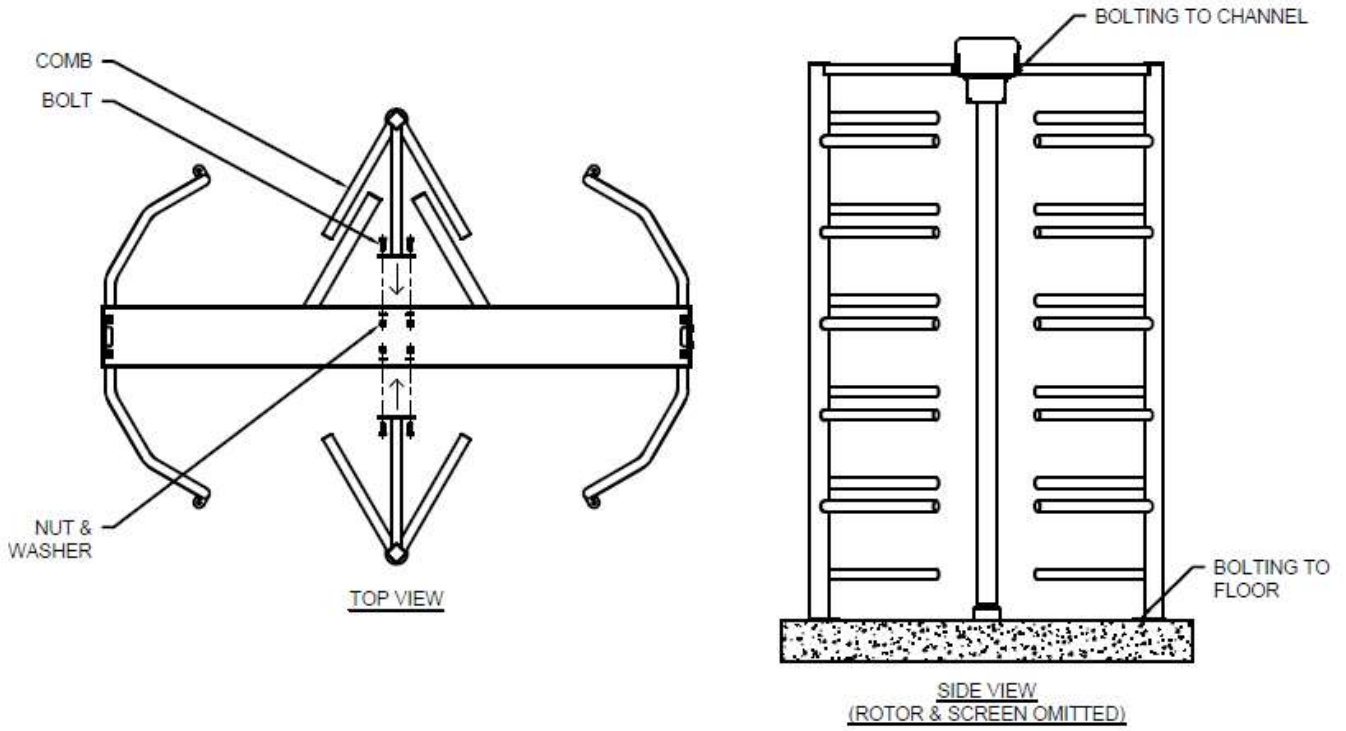




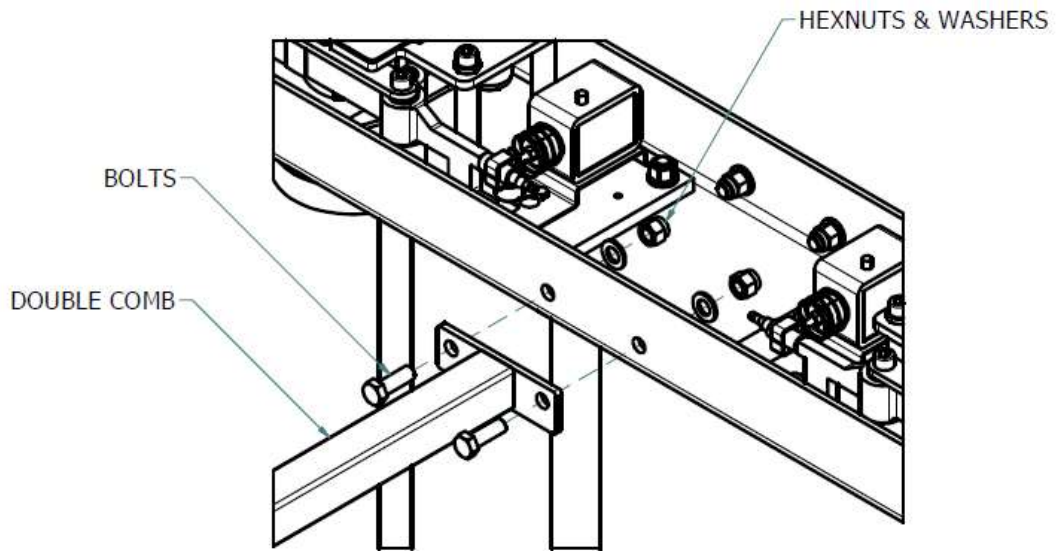
**Figure 16: Double Assembly Details**



**Figure 17: Double turnstile assembly**



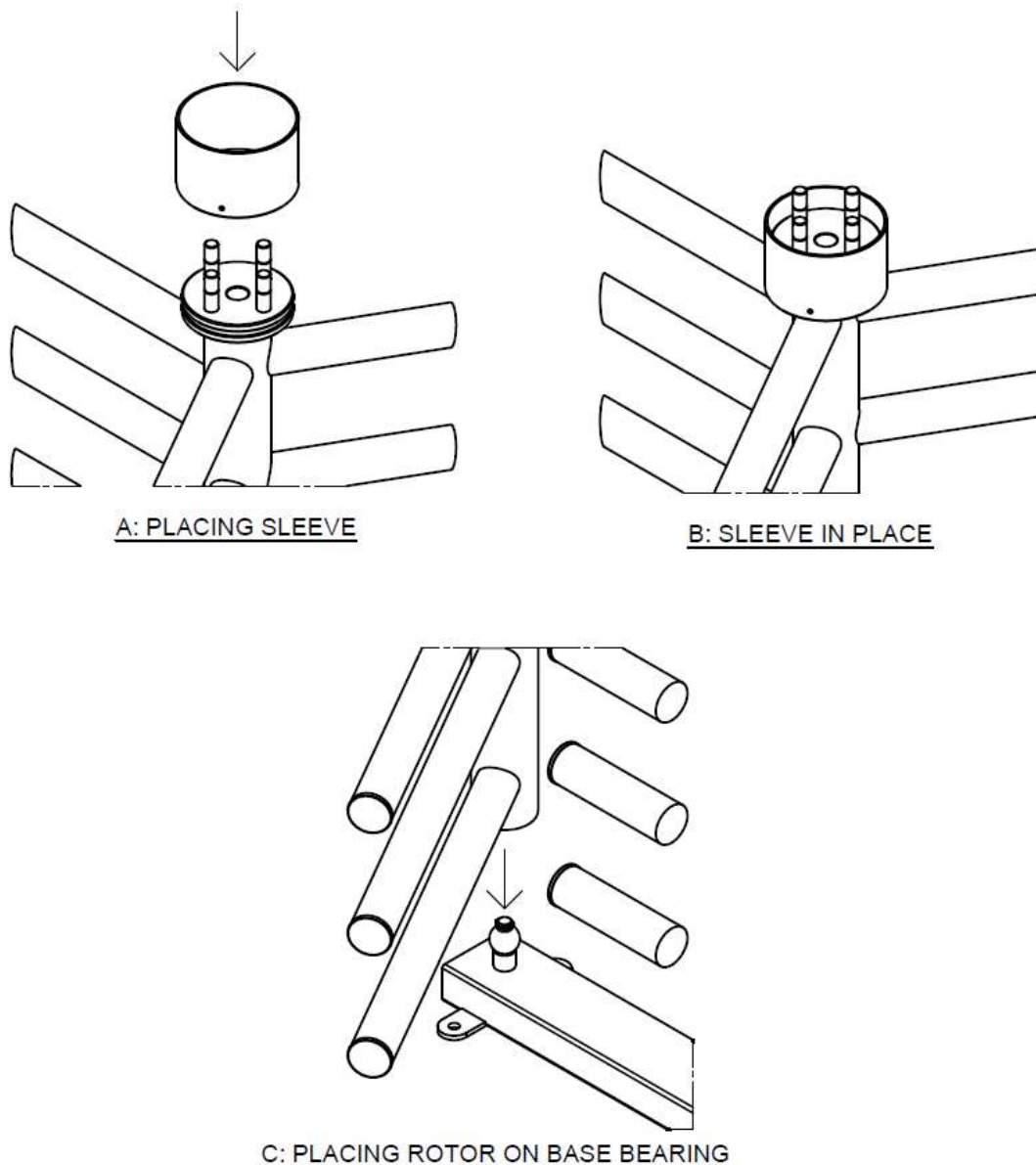
**Figure 18: Double Comb Assembly**



**Figure 19: Double Comb Fixing to Channel**

## 6. ROTOR ASSEMBLY

- 6.1. Loosen and remove the four M12 bolts which secure the mechanism to the top channel. Also remove the washers and bean washers.
- 6.2. Slide the sleeve over the rotor top disk. Allow the sleeve to top of the uppermost arms.
- 6.3. Place the base of the rotor onto the base bearing. Unbolt mechanism and move to the side. Insert rotor, then drop mechanism onto rotor, ensuring the holes in the mechanism disk slides onto the four M16 studs on top of the rotor disk.



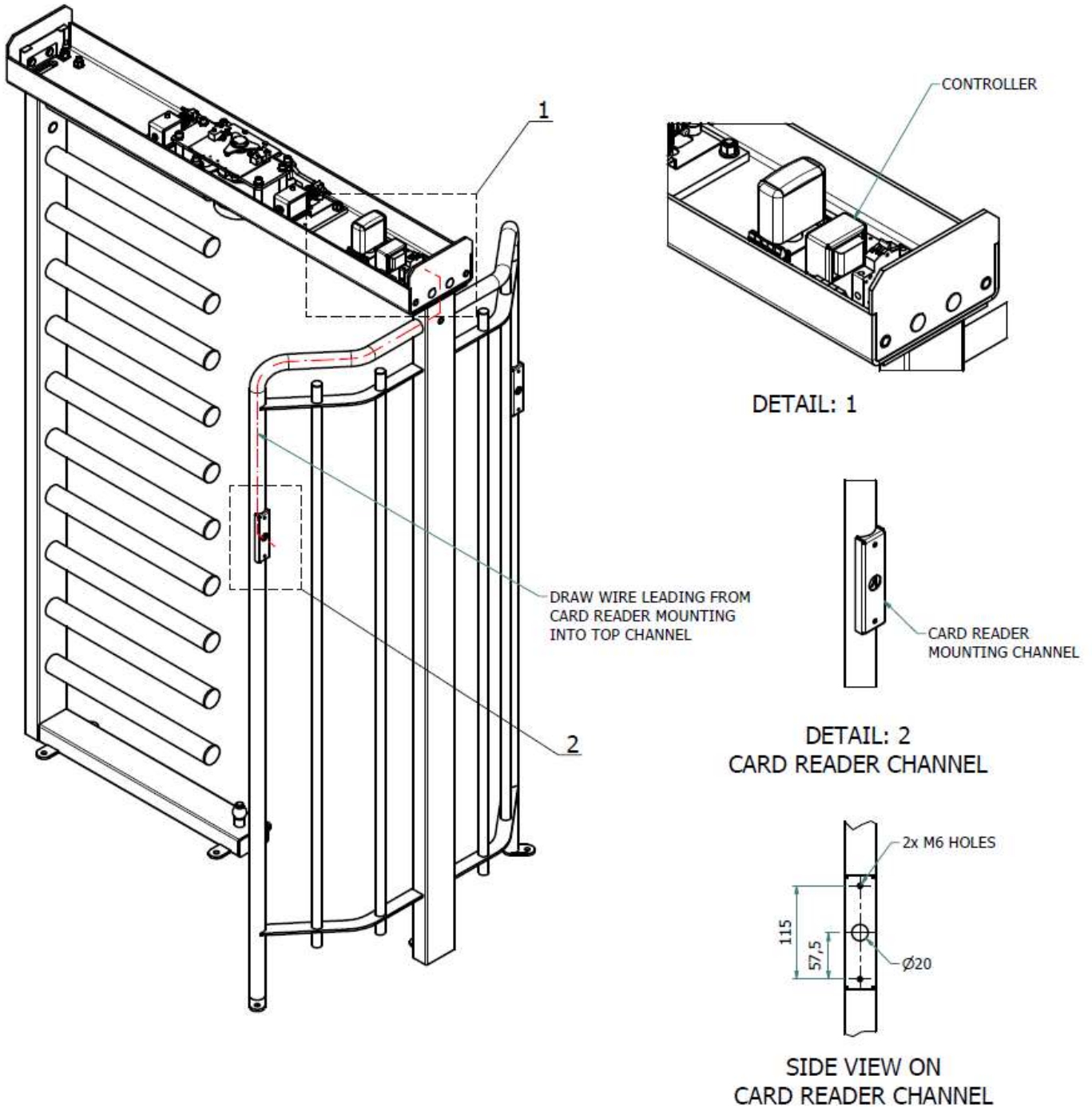
**Figure 20: Rotor Assembly Details**

- 6.4. Reinsert and tighten the four M12 bolts which secure the mechanism to the top channel.

- 6.5. Place the bean washers over the M16 studs on the top disk and fasten using four M16 nylock hexnuts. Tighten each nut incrementally. As tightening is done, the rotor will be raised into position. Tighten until there is a 1mm gap between the rotor top disk and rubber buffer disk.
- 6.6. Raise the sleeve into position to cover the rotor coupling. Align and tighten the 4mm grub screws on the sleeve within recessed groove in the rotor top disk.

## 7. CARD READER CHANNEL MOUNTING & DRAW WIRES

7.1. Connect power, triggers and test the unit (See section 13). Draw wires are provided from the card reader mounting channels to the top channel and can be used to lead the cables from the card reader to the control panel.

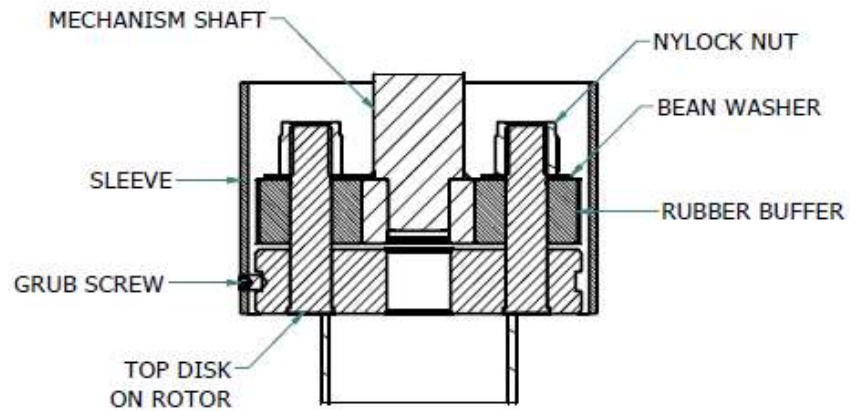


**Figure 21: Card Reader Mounting Channel & Draw Wire**

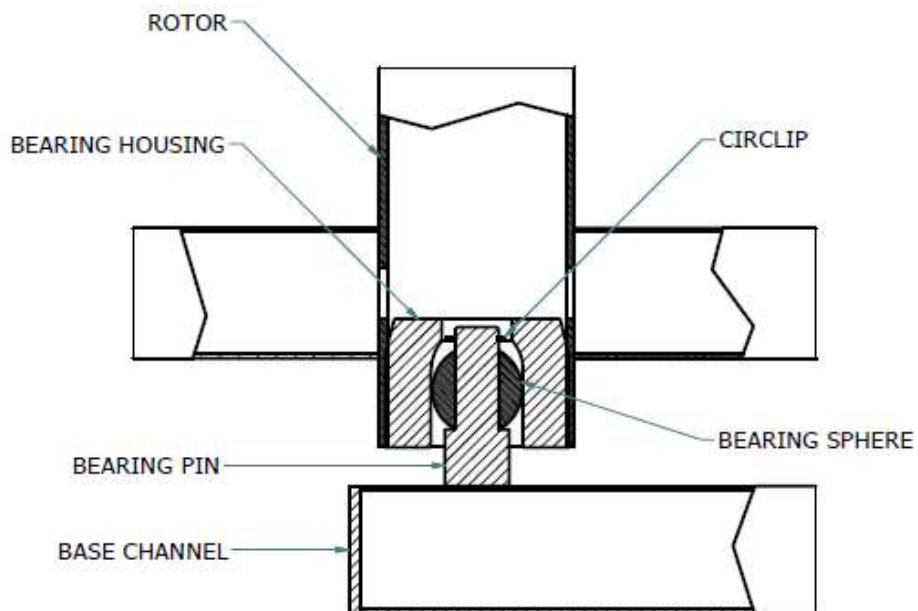
- 7.2. Suitable card reader brackets can be bought from Turnstar.
- 7.3. After turnstile is fully functional, fit the turnstile top cover in place and lock with the key provided.

## **8. FURTHER ROTOR ASSEMBLY INFORMATION**

- 8.1. The rotor is suspended from the mechanism, and only requires a bearing sphere at the base to keep it centralised. See Figure 22: Views on Top Disk & Base Bearing, view 2. Lower the rotor onto the bearing sphere, with the rotor internal bush keeping it centric.
- 8.2. Place mechanism with rubber buffer disk onto the studded top disk of the rotor.
- 8.3. Lower the mechanism onto the rotor, so the mechanism shaft and rubber washers fit over the studs in the rotor disk, ensuring the rotor is aligned with one arm pointing directly toward the screen. Place the bean washers over the studs on the rubber buffers and the hex nylock nuts above the bean washer onto the top studs.
- 8.4. When tightening the nylock nuts, the rotor will lift. Tighten until the arms are aligned central between the arms of the comb. There should be a 1mm gap between the mechanism disk and the rotor top disk.
- 8.5. Lift the sleeve and tighten with the grub screws biting into the groove in the rotor disk.



VIEW: 1  
TOP DISK



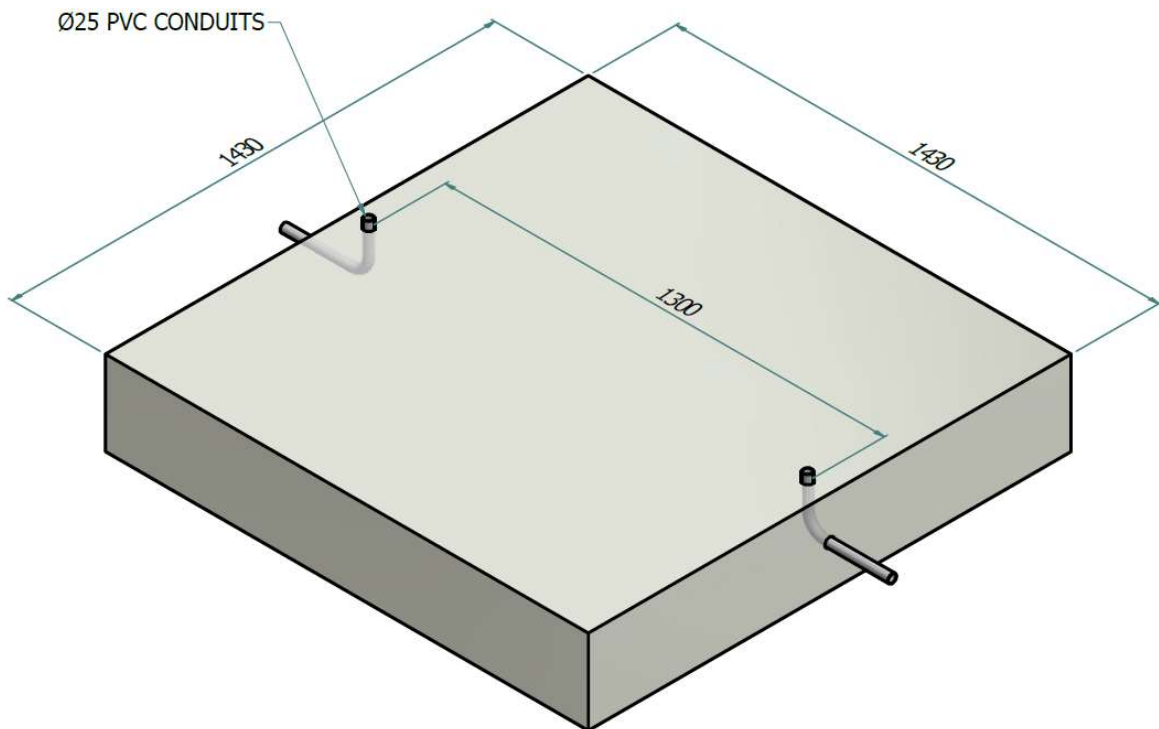
VIEW: 2  
BASE BEARING

**Figure 22: Views on Top Disk & Base Bearing**



## 9. INSTALLATION

- 9.1. The turnstile must be secured in place on a level concrete plinth or tiled finished floor.
- Single Turnstile Specification: 1430mm long x 1430mm wide x 125mm deep, 20MPa strength concrete. (See Figure 13)
  - Double Turnstile Specification: 2180mm long x 1430mm wide x 125mm deep, 20MPa strength concrete. (See Figure 17)
- 9.2. Provision for power and data (where required) cabling must be made prior to the turnstile installation. Power and data cabling can enter the turnstile in one of four positions.
- Floor position A
  - Floor Position B
  - High Level side entry A
  - High Level side entry B



**Figure 23: Isometric view on plinth and conduits provision**

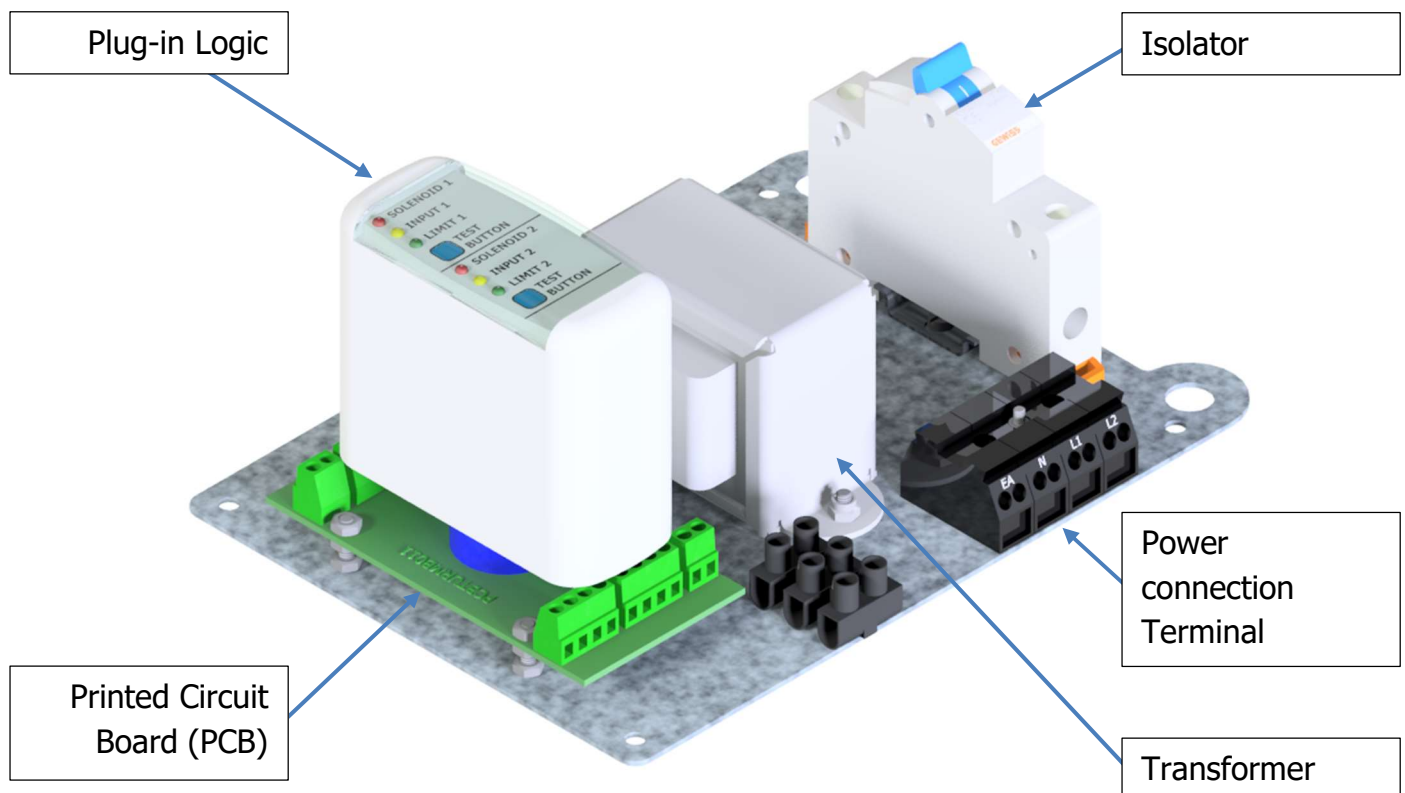
- 9.3. Recommendation: It is strongly recommended that the comb of a single turnstile be bolted to a robust structure, such as a wall or fencing post. This provides extra stability.
- 9.4. Position the assembled turnstile at the desired installation point.
- 9.5. Feed power and data cabling to the turnstile control panel.
- 9.6. Ensure the turnstile is level, positioned straight and that the distance between the outside of the screen and comb is 1400mm (2150mm for a double between the outside of the two screens) at floor level.
- 9.7. Bolt the turnstile to the floor using M10x75 coach bolts with nylon plug. Where possible, bolt the turnstile comb and screen to a robust structure (to provide extra stability).

Note:

- The turnstile can be installed on floor tiles.
- The turnstile cannot be installed directly onto brick paving as the bricks tend to crack during/-after installation.
- When installing a security gate or fence beside the turnstile, the gate/-fence should not be welded to the turnstile. Welding damages the finish of the turnstile and can cause corrosion. If a fixing is required, the item can be bolted to the turnstile through the hole provided in the comb/-screen.
- Care must be taken to prevent concrete from getting onto the turnstile. Concrete removed by builders can cause corrosion on the turnstile.

## 10. **CONTROL PANEL & LOGIC**

- 10.1. The control panel consists of a 220v AC power connection terminal, leading to an isolator. The isolator leads to an 18VAC transformer (sometimes 19V or battery backup) which distributes power to the printed circuit board and the plug-in logic. All the components are mounted onto a pre-galvanised chassis plate.
- 10.2. The plug-in logic controls the functions of the turnstile. (The logic may differ from the image shown. See Section 11.



**Figure 24: Turnstile control panel components**

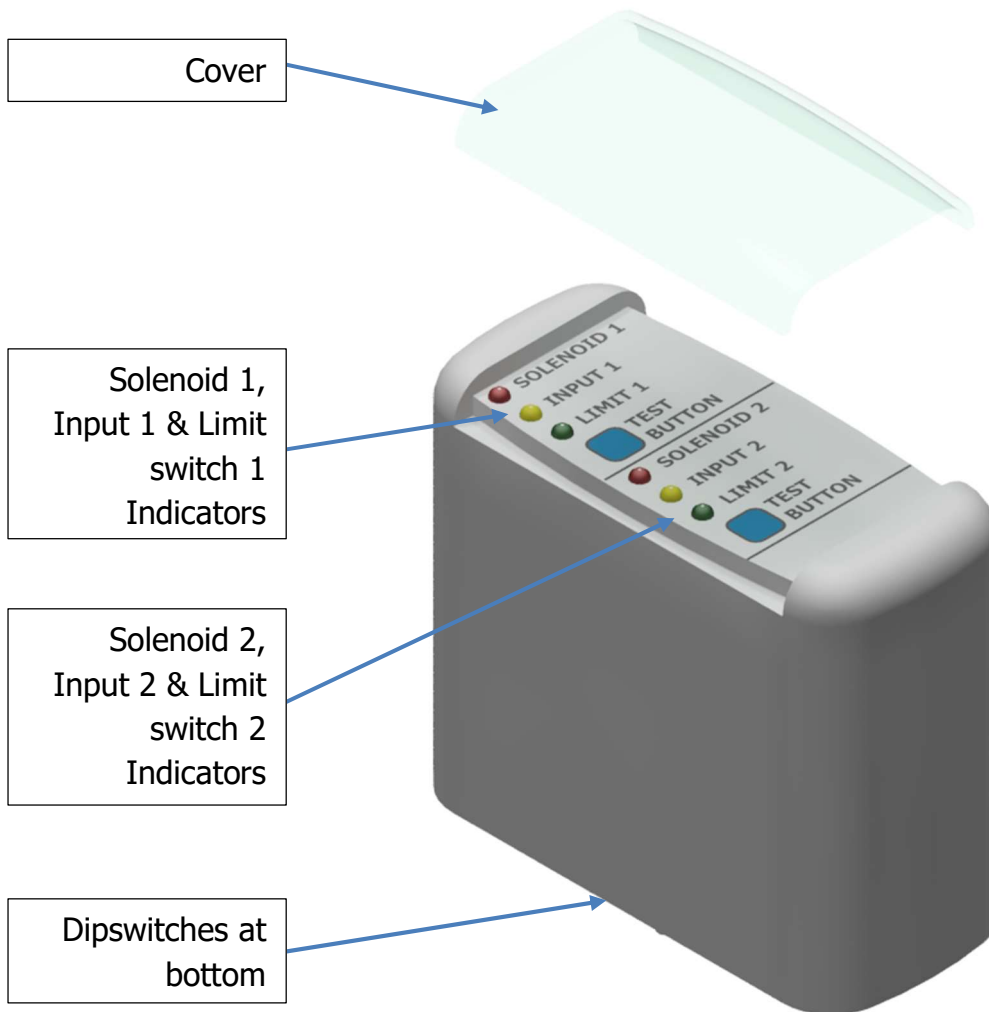
- 10.3. The trigger inputs on the logic are activated by a potential free contact (dry contact).
- 10.4. The limit switch inputs on the logic are activated by a potential free contact (dry contact).
- 10.5. The solenoid outputs on the logic are solid state MOSFET rated at 1,5A / 24VDC.
- 10.6. The EOT (End of transaction) outputs on the logic are normally open relays rated at 0,5A / 24 VDC.

## 11. TURNSTILE LOGIC TYPES

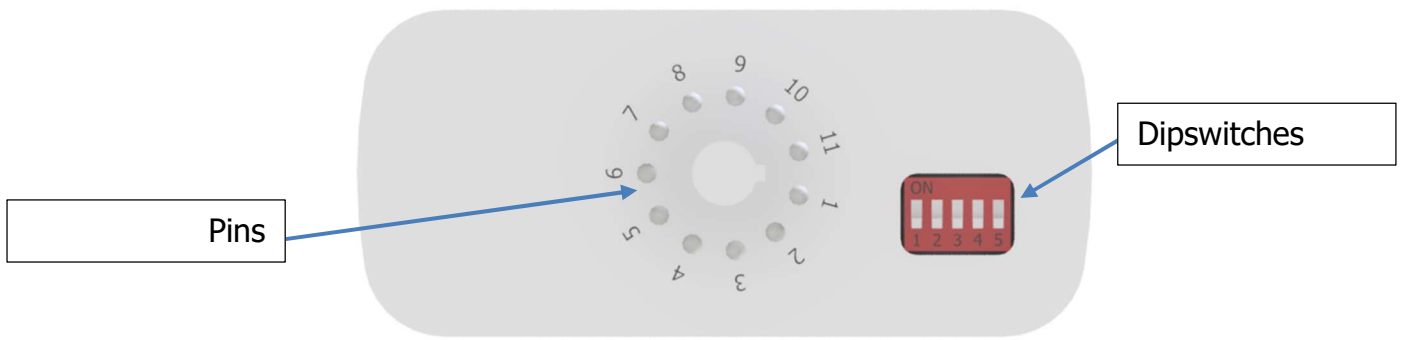
11.1. The control panel may be using one of two plug-in logics. Both logics have the same operation and features and are interchangeable. The grey logic (TURTL373) is mainly used locally in South-Africa and neighbouring countries. The blue logic (TL300TUR) is mainly used for exports to other countries.

11.2. The face of the logic incorporates two blue test buttons and six diagnostic LED indicators.

11.3. To test the grey logic, press one of the test buttons briefly.



**Figure 25: Grey Plug-in Logic (TURTL373)**



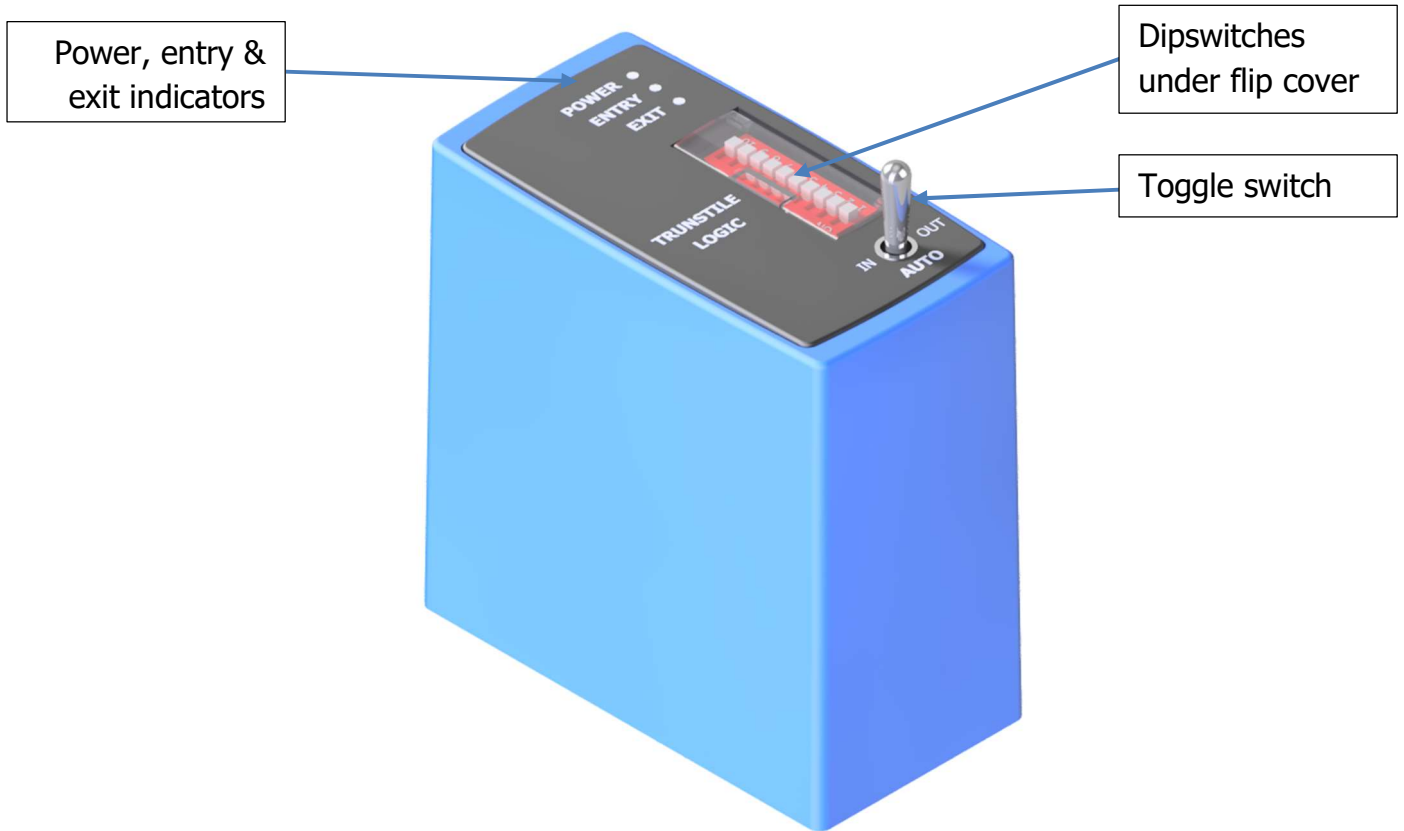
**Figure 26: Base of Grey Plug-in Logic (TURTL373)**

**Table 1: TURTL373 Logic Dipswitch Settings**

Switch No.	Function	ON	OFF
5	Sound	On	Off
4	Solenoid 2	Fail-Secure	Fail-Safe
3	Solenoid 1	Fail-Secure	Fail-Safe
2	Input 2 (Direction 2) (Fire Alarm)	Extended Trigger	Once-off Trigger
1	Input 1 (Direction 1) (Fire Alarm)	Extended Trigger	Once-off Trigger

11.4. The blue logic (TL300TUR) has a section showing feedback LED, dipswitches under a flip-open cover and a toggle switch for testing. The feedback section shows when the logic has power, when an entry trigger is received and when an exit trigger is received. The toggle switch must always be in the centre for automatic mode.

11.5. To test the grey logic, flip the toggle switch briefly to either 'in' or 'out' and return it to the centre.



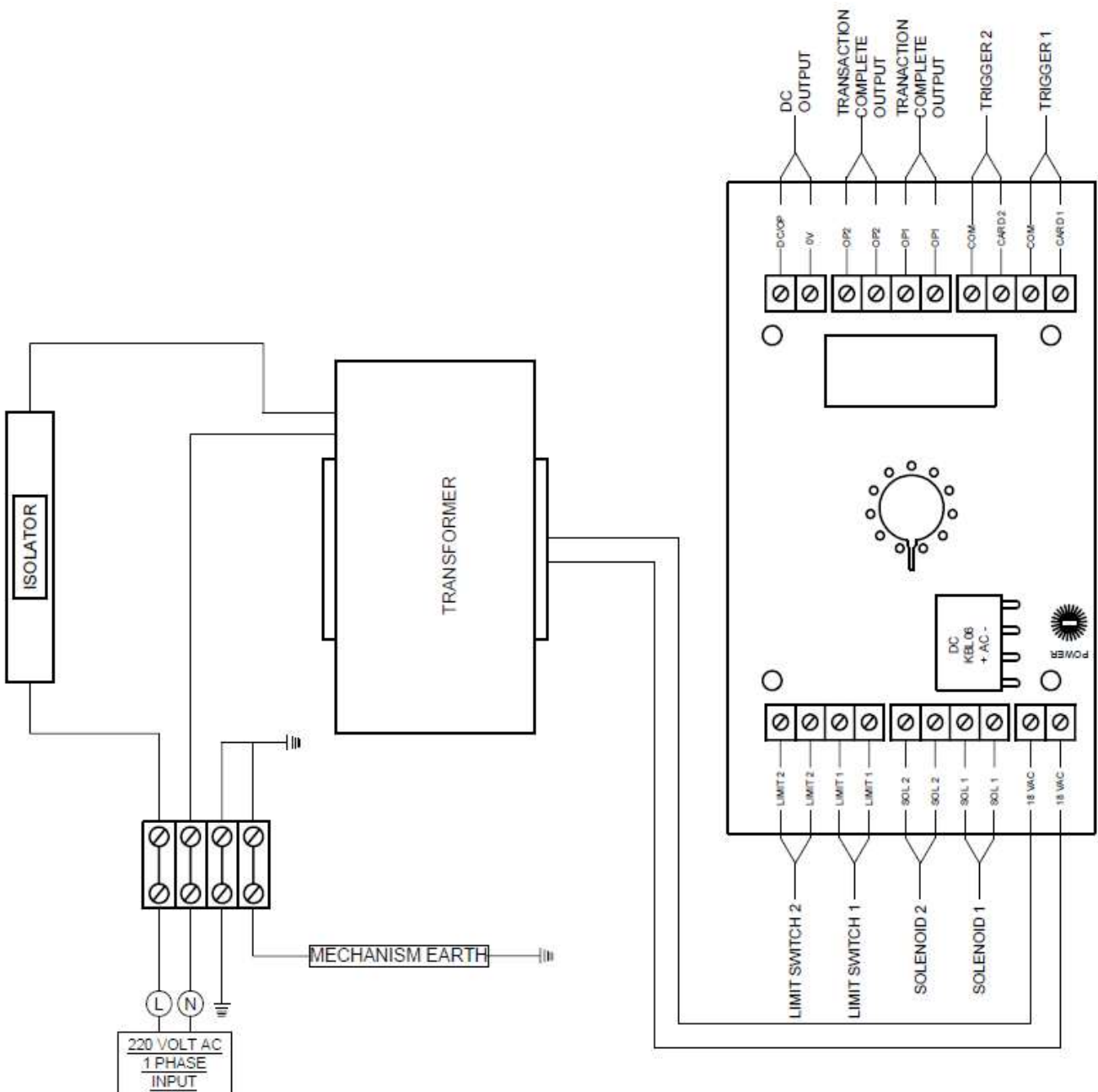
**Figure 27: Blue Plug-in Logic (TL300TUR)**

**Table 2: TL300TUR Logic Dipswitch Settings**

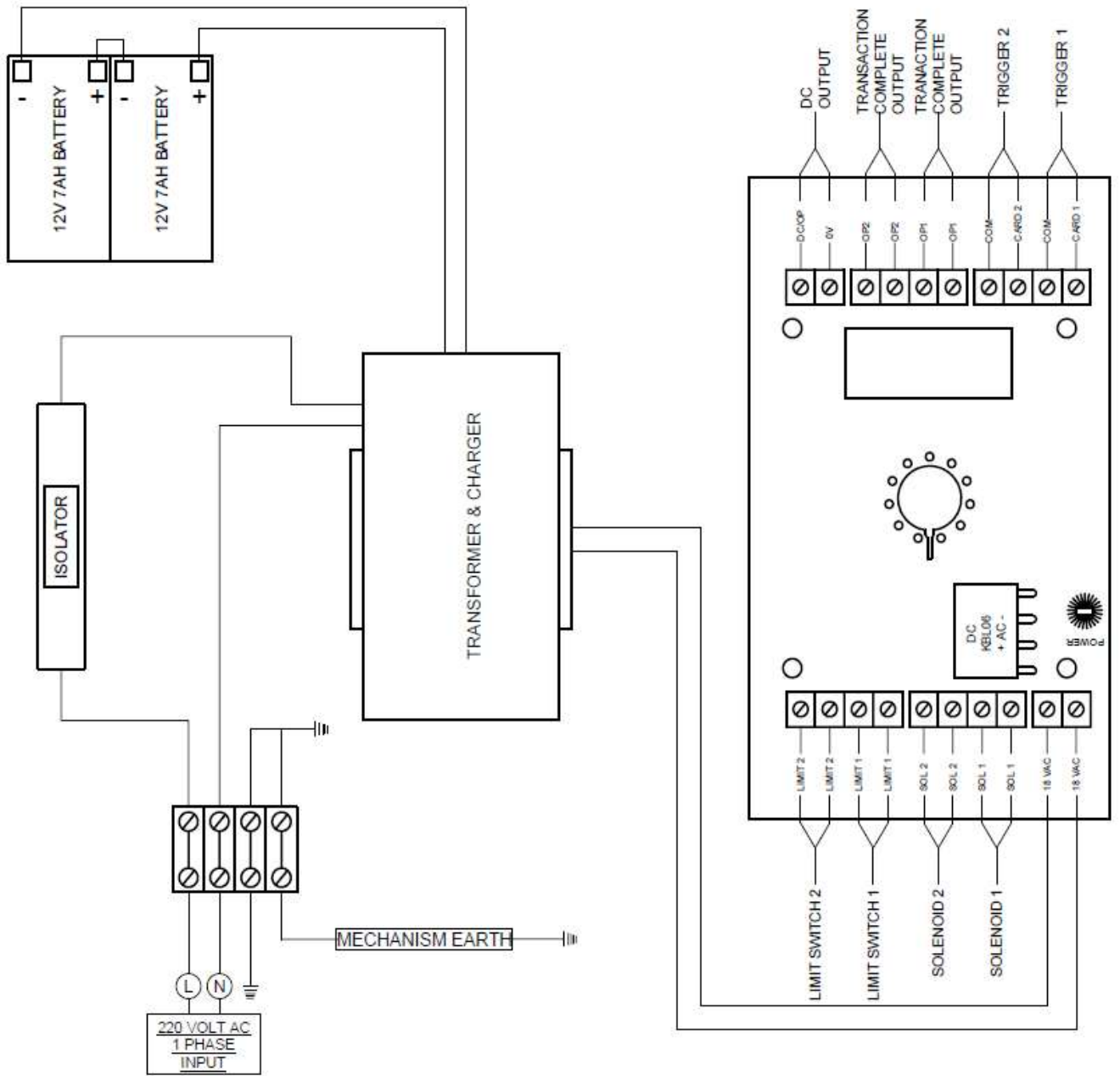
Switch No.	Function	ON	OFF
10	Not used	Reset	Off
9	Not used	-	Off
8	Timeout	10 Sec.	20 Sec.
7	Trigger memory	On	Off
6	Exit trigger latch	Enable	Off
5	Entry trigger latch	Enable	Off
4	Relay output mode	LED / Buzzer mode	Transaction Complete Mode
3	Entry/ Exit trigger input	N/C	N/O
2	Exit Solenoid	Fail Safe	Fail Secure
1	Entry Solenoid	Fail Safe	Fail Secure

## 12. WIRING DIAGRAMS

12.1. The control panel consists of a 220v AC power connection terminal, leading to an isolator. The isolator leads to the transformer which distributes 18VAC power to the printed circuit board and the plug-in logic. All the components are mounted to a pre-galvanised plate.



**Figure 28: Wiring Diagram for Full Height Turnstile**



**Figure 29: Wiring Diagram for FH Turnstile with Battery Backup**



### **13. STANDARD FACTORY SETUP**

- 13.1. Ensure mains power is switched off.
- 13.2. Connect the mains power cable to the turnstile controller at the power connection terminal.
- 13.3. Connect the access control relay output to the triggers on the PCB (Trigger 1 and Trigger 2), one for each direction. The trigger to unlock the turnstile is a dry-contact, potential free input. The closing signal should be no longer than 0,5 seconds.
- 13.4. Switch on the mains power.
- 13.5. Check that mains power is being distributed to the control board.
- 13.6. Test the turnstile unlocking by triggering the access control system. Confirm the direction that is being opened is correct as required by the access control. If it is not, swap the trigger inputs on the control panel.
- 13.7. When triggering, walk through the turnstile. When exiting, the turnstile rotor will lock, not allowing further entry. Repeat this for the opposite direction.
- 13.8. If the turnstile does not trigger from the access control system, test the logic using the button or toggle provided.

## 14. **FIRE ALARM SET-UP**

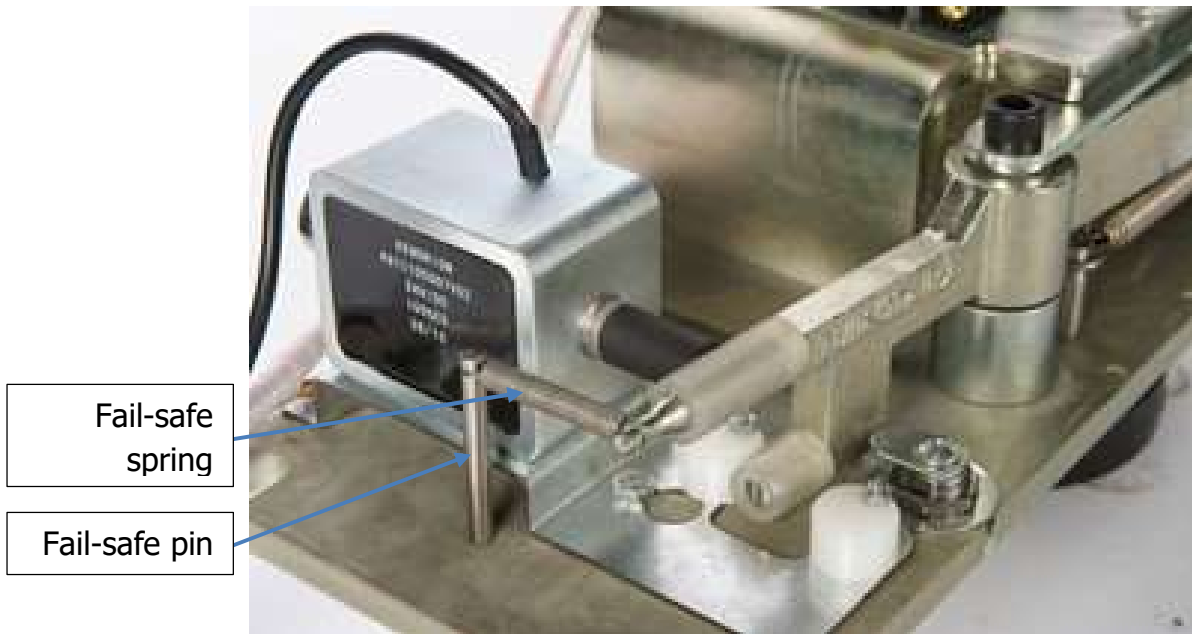
- 14.1. If the grey logic is used (TURTL373), ensure dipswitches 1 & 2 is switched **ON**. When giving an extended trigger to either trigger 1 or trigger 2 from the access control, the turnstile will be open, and any number of pedestrians can pass through. The turnstile will remain open until the extended trigger is removed.
- 14.2. If the blue logic is used (TL300TUR), ensure dipswitches 6 and 7 is switched **ON**. When giving an extended trigger to either trigger 1 or trigger 2 from the access control, the turnstile will be open, and any number of pedestrians can pass through. The turnstile will remain open until the extended trigger is removed.

## 15. **FAIL-SECURE AND FAIL-SAFE**

- 15.1. The turnstile mechanism can be configured either in fail-safe or fail-secure. The default factory setting is fail-secure.
- 15.2. A fail-safe mechanism configuration unlocks the rotor to freely rotate in the case of a power-failure.
- 15.3. A fail-secure mechanism configuration locks the rotor in case of power failure. In this case, if the rotor is required to be unlocked, this can be done by unlocking the mechanical over-ride with the key provided.



**Figure 30: Solenoid in Fail-secure arrangement**



**Figure 31: Solenoid in Fail-safe arrangement**

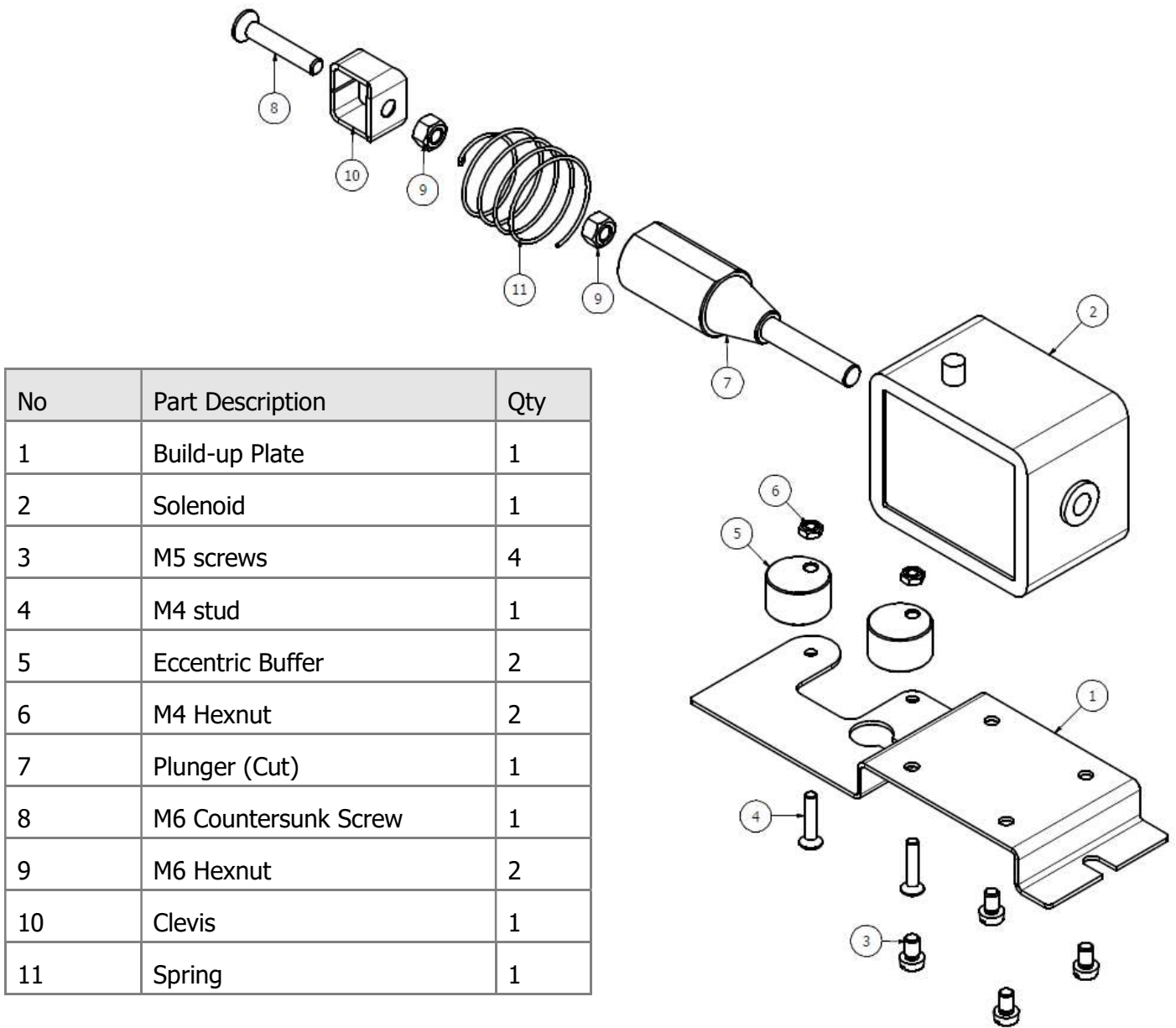
15.4. If fail-safe, a solenoid is 'pushing' on the pawl when under power. When in fail-secure, a solenoid is pulling when under power.

15.5. For **Fail-Secure** setting, on the logics,

- Grey Logic (TURTL373) – Ensure dipswitches 2 and 3 are **ON**.
- Blue Logic (TL300TUR) – Ensure dipswitches 1 and 2 are **OFF**.

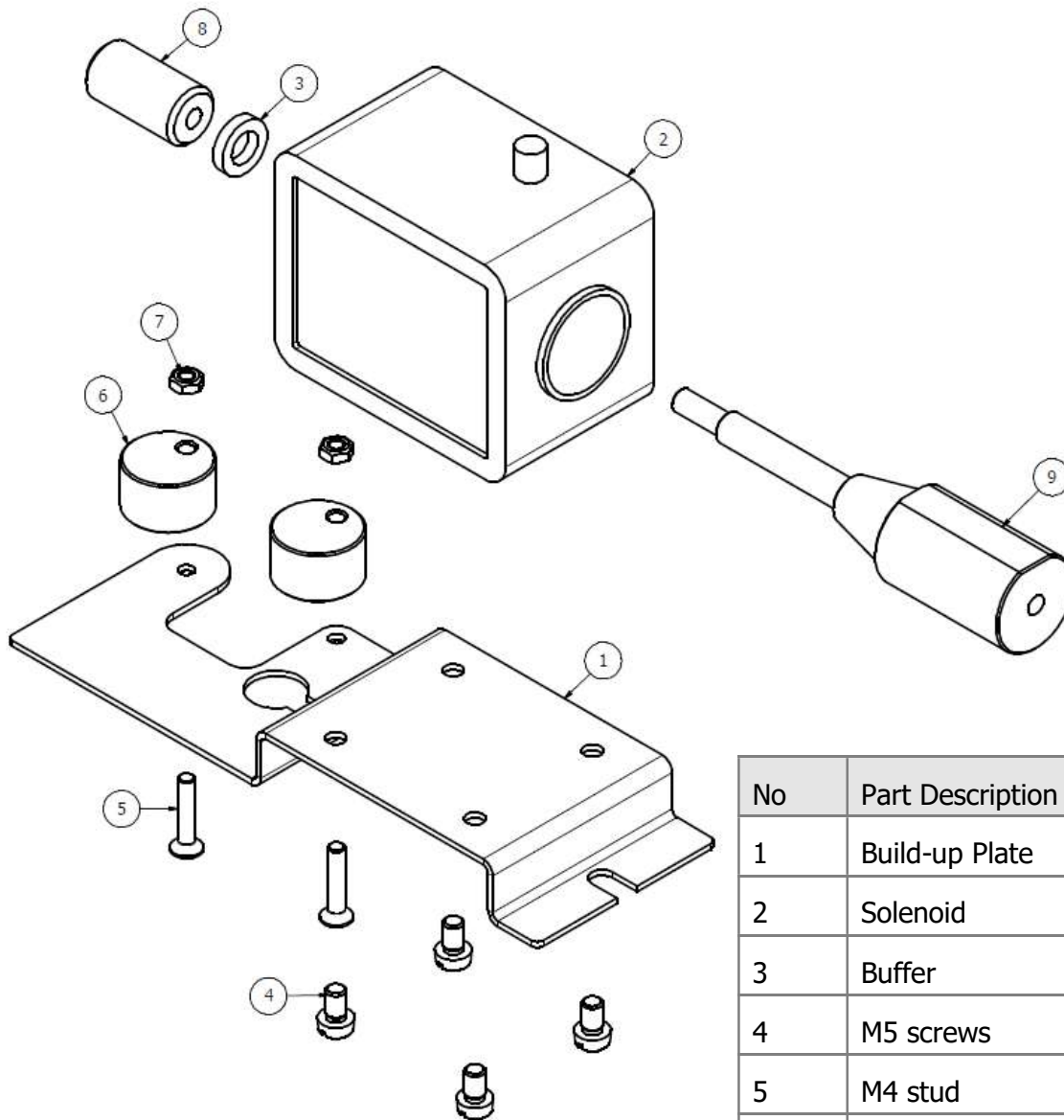
15.6. For **Fail-Safe** setting, on the logics,

- Grey Logic (TURTL373) – Ensure dipswitches 2 and 3 are **OFF**.
- Blue Logic (TL300TUR) – Ensure dipswitches 1 and 2 are **ON**.



No	Part Description	Qty
1	Build-up Plate	1
2	Solenoid	1
3	M5 screws	4
4	M4 stud	1
5	Eccentric Buffer	2
6	M4 Hexnut	2
7	Plunger (Cut)	1
8	M6 Countersunk Screw	1
9	M6 Hexnut	2
10	Clevis	1
11	Spring	1

**Figure 32: Solenoid assembly – Fail-secure**



No	Part Description	Qty
1	Build-up Plate	1
2	Solenoid	1
3	Buffer	1
4	M5 screws	4
5	M4 stud	1
6	Eccentric Buffer	2
7	M6 Hexnut	2
8	Cam	1
9	Plunger	2

Note, when placing the fail-safe solenoid build up, also install the fail-safe pin and spring to the pawl, shown in Figure 31.

**Figure 33: Solenoid assembly – Fail-safe**

## 16. MAINTENANCE

16.1. The recommended maintenance interval is every 12 months.

**Table 3: Recommended Maintenance Procedure**

No	Part Description	Check
1	Cleaning of all external powder coated surfaces	
2	Checking fixing and functionality of all turnstile keyed locks in top cover and for mechanism (key 60198)	
3	Cleaning of turnstile mechanism and top channel	
4	Checking of turnstile mechanism pawl settings and application of grease to pawls and locking disk	
5	Checking of turnstile solenoid operation & positioning and cleaning with alcohol	
6	Microswitch adjustment, if necessary (2x microswitches)	
7	Checking of turnstile battery backup system	
8	General functionality: Enter turnstile and become trapped. Trigger for access to be granted and finish the entry (do this for both clockwise and anti-clockwise directions)	
9	General functionality: Enter turnstile and become trapped. Allow for time-out and return to the outside position (do this for both clockwise and anti-clockwise directions)	
Turnstile Serial Number:		
Date of maintenance:		
Maintenance carried out by:		
Turnstile Serial Number:		
Date of maintenance:		
Maintenance carried out by:		

## 17. CLEANING

- 17.1. Depending on the finish of the turnstile, different cleaning instructions will apply.
- 17.2. Dusting – Dust turnstile with a feather duster or soft cloth.
- 17.3. Wash – Cleaning of turnstile to be done with a soft cloth (non-abrasive) dipped into a mixture of warm water and mild dishwashing liquid (alkaline-based cleaner with a pH of 12 or lower). Then rinse the turnstile with clean water. Do not spray with high pressure water near the top channel as water can damage the internal electronics.

**Table 4: Recommended Cleaning Frequency**

Type	Action
Powder-coated mild steel	Dust once a month
	Wash stubborn dirt in the affected area
Hot-dipped Galvanised mild steel	Dust once a month
	Wash stubborn dirt in the affected area
304/316 grade stainless steel	Wash the entire turnstile twice a month with warm soapy water and a soft cloth
Powder-coated 304/316 grade stainless steel	Dust once a month
	Wash stubborn dirt in the affected area

## 18. **SPARE PARTS**

18.1. The below table shows the suggested spare parts to keep on hand for servicing the turnstile or to repair the turnstile in an emergency.

**Table 5: Spare Parts List**

Part Description	Qty
Transformer	1
Battery Backup UPS power supply	1
Battery	2
PC Board	1
Plug-In Logic (Ultitech or Procon)	1
Microswitch	2
Solenoid	2
Lock with Key	2
Lock cam	2
Indexing Roller	1
6mm Key	1
Clevice	2
Fail-secure spring	2
Fail-safe spring	2



## 19. FAULT FINDING

Fault	Cause	Solution
Turnstile rotates continuously, even without power.	The over-ride lock might be unlocked with the key.	The over-ride lock might be unlocked with the key.
Turnstile does not unlock automatically on power failure when in fail-safe mode.	The mechanism is not set-up for fail-safe.	Check if the mechanism is set-up for fail-safe operation.
	The logic is not set for fail-safe operation.	Set the logic for fail-safe operation.
Turnstile unlocks automatically on power failure when in fail-secure mode.	The mechanism is not set-up for fail-secure.	Check if the mechanism is set-up for fail-secure operation.
	The logic is not set for fail-secure operation.	Set the logic for fail-secure operation.
Turnstile does not unlock.	Solenoid needs cleaning.	Clean solenoid with alcohol. No Q20 allowed to be used for cleaning.
Turnstile rotor does not self-centre.	Indexing spring broken.	Replace indexing spring.
3-arm Turnstile trapping you	Assembly is wrong.	Check the rotor assembly and correct.
4-arm Turnstile trapping you.	Microswitches are wired incorrect.	Correct wiring on microswitches.
Batteries are not charging.	Battery output voltage incorrect.	Check output of battery backup UPS power supply and adjust output voltage to 27,6v.
Turnstile is on but does not rotate on trigger activation.	Trigger not received by control panel.	Isolate where the fault could be. Test the turnstile using either the test pushbuttons or toggle switch provided on the plug-in logic.
	Access control trigger faulty.	Check for continuity on the access control trigger.
	Possible faulty PC board.	Trigger either card 1 or card 2 terminals to isolate if there is a fault on the PC board.
Turnstile allows more than 1 person to go through at a time.	Trigger signal extended.	Check if the fire-alarm settings are active and check the length of trigger

		activation. The signal may be too long and should be $\frac{3}{4}$ of a second or less.
	Faulty microswitch.	Check if a microswitch is faulty or broken. Replace microswitch.
Arms of turnstile are colliding or scraping against the comb.	Rotor lowered.	Check mechanism. The circlip may be damaged and the rotor may have dropped.