



catrax  
*clip*



[www.TURNSTILES.us](http://www.TURNSTILES.us)

[www.TURNSTILES.us](http://www.TURNSTILES.us) / [www.entrapass.com](http://www.entrapass.com)  
8641 S. Warhawk Road, Conifer, CO 80421 / 303-670-1099

## TABLE OF CONTENTS

---

<b>1 DIRECTIONS</b> .....	<b>3</b>
<b>2 INTRODUCTION</b> .....	<b>3</b>
<b>3 CATRAX CLIP CHARACTERISTICS</b> .....	<b>4</b>
3.1 CATRAX Clip operation.....	5
<b>4 CATRAX CLIP INSTALLATION AND ASSEMBLY</b> .....	<b>6</b>
4.1 Opening the package.....	6
4.2 Drilling the floor.....	7
4.3 Fastening the column .....	7
4.4 Arm Assembly .....	8
4.5 Access to the CATRAX Clip after assembly .....	9
<b>5 INSTALLATION/ASSEMBLY OF OPTIONAL ITEMS</b> .....	<b>9</b>
5.1 Deposit kit with urn.....	9
5.1.1 Connecting the deposit kit to the control board .....	10
5.2 Pictogram kit.....	11
5.3 Power supply.....	11
5.4 Control board .....	11
5.4.1 Inputs.....	13
5.4.2 Outputs.....	13
5.4.3 Control board configuration – Dip Switch DS1 .....	15
5.4.4 Examples of configurations.....	16
<b>6 MAINTENANCE</b> .....	<b>16</b>
6.1 Preventive and corrective maintenance schedule .....	16
6.2 Troubleshooting .....	18
<b>7 TECHNICAL CHARACTERISTICS</b> .....	<b>19</b>

## 1 DIRECTIONS

---

- Thoroughly read the information and instructions contained in this manual before using the product. This will extend the life of the product and will enable you to fully benefit from all its features.
- This product was not designed for outdoor use in unprotected areas.
- Retain this manual for future reference.

## 2 INTRODUCTION

---

Following a new technological concept focused on sturdiness and reliability, and with innovative design elements, such as varied colors and broadly curved lines, Digicon has launched as part of the CATRAX line the Clip model, aimed at serving physically disabled persons.

CATRAX Clip meets the needs of the vast majority of access control technologies presently available, being acclaimed as the best option in the access control market.

### 3 CATRAX CLIP CHARACTERISTICS

---

The CATRAX Clip is an access control miniblock model (column type) aimed at persons with physical disabilities features an arm with brushed stainless steel (AISI 304) finishing and a two-way mechanism with horizontal movement.



The column finishing may be either in brushed stainless steel (AISI 304) or 1020 carbon steel with black epoxy powder electrostatic coating. It features a reinforced structure, fully rounded corners and with no exposed screws, offering space and comfort for practically any access control solution. It also features a space for a collection safe (optional item).

In order to simplify maintenance and assembly, the CATRAX Clip column has an internal U-shaped mounting rack (drawer type) with standard drilling to mount optional electronic boards. Also, extra drilling can be done by the customer according to their needs. Access to the mounting bracket is through a key with a code, and it is removed and inserted through the front door.



The top panel comprises a plastic cover and a stainless steel plate. The cover is made in an injected plastic structure and is available in stainless steel or black (other colors available upon request). Optionally, the cover may feature a slot for reading magnetic or bar code tags/cards.

The top cover stainless steel plate allows for easy configuration and customization of the product at a low cost. The plate can also feature slots for optional items, such as pictogram, deposit urn spout, display kit, or a combination of these items. The figures below show some of these options.

Detail of top cover: flat and with spout to deposit cards.



Detail of pictogram



As well as compatibility with the vast majority of available technologies, Digicon can provide the following optional items:

deposit kit with urn, pictogram kit, power SUPPLY, and control board. These items are described in greater detail in section 5 Installation/Assembly of optional ITEMS

**NOTE**

For detailed information on the dimensions of CATRAX Clip components, see section 7 TECHNICAL CHARACTERISTICS, page 19 in this manual.

**3.1 CATRAX CLIP OPERATION**

The CATRAX Clip basic mechanism features a two-way turning system with horizontal movement, two 12V electromagnets to activate the locks and two optical sensors that can supply a signal to activate the electromagnets and return the passage.

In the electronic model, which features a micro processed control board (optional), a signal that enables the passage is sent through one of the inputs depending on the direction of passage. If this signal is recognized, the equipment will allow the CATRAX Clip arm to move forward. Once half the turn (45 degrees) is completed, a 400 millisecond return signal is sent informing the direction of passage.

Depending on the CATRAX Clip configuration and model, forcing the arm in the absence of an enabling signal will activate an electromagnet and block the passage. Also, the equipment may also send a signal for an audible alarm and/or activate the pictogram in red in the front panel(models with pictogram). In this case, a return signal is sent indicating that the access controller was forced and informing the direction.

## 4 CATRAX CLIP INSTALLATION AND ASSEMBLY

### 4.1 OPENING THE PACKAGE

As the package may contain varied items (depending on the customer order), it is extremely important to carry out a thorough visual inspection before starting the installation and assembly process. All the Digicon packages include a checklist as a guide for the inspection.



#### ATTENTION

To avoid losing the bolts used to assemble the CATRAX Clip, and the spanners, these are shipped taped to the cardboard. Thus, before disposing of any wrapping material (plastics and cardboard), make sure that all the items in the checklist are there.

See below the parts that may come with your CATRAX Clip:

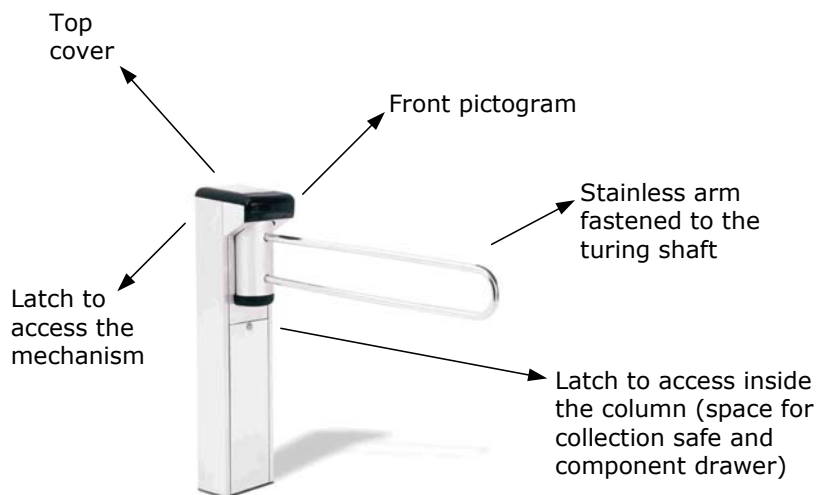

#### NOTE

As well as the items above, CATRAX Clip may be supplied with a poser supply kit and a control board.

#### 4.2 DRILLING THE FLOOR

Before installing the CATRAX Clip, check:

1. The site chosen to install the equipment.
2. Whether there is an power source or socket close by (installation ducts).
3. Whether the site chosen is adequate to install the access controller (closed environments).
4. Whether there is enough clearance (at least 5 cm) between the rear part of the CATRAX Clip column and the wall. This clearance is important to ensure access to the top panel locks and the cable passage cover.
5. Whether there is enough room for the arms to turn once the CATRAX Clip is assembled. For further details concerning equipment dimensions, see item 7 TECHNICAL CHARACTERISTICS, page 19 in this manual.
6. Whether the floor is in condition to receive anchor bolts (minimum 4 cm of FCK15 MPa concrete or equivalent).

#### ATTENTION

Since installation of the CATRAX Clip requires drilling the floor, it is extremely important that the installation site be chosen carefully.

#### 4.3 FASTENING THE COLUMN

To fasten the column to the floor, follow the steps and figures indicated.

1. Drill the floor with a 3/8" bit (redrill with a 12 mm or 1/2" bit). Make four external holes according to measurements indicated in the figure below.

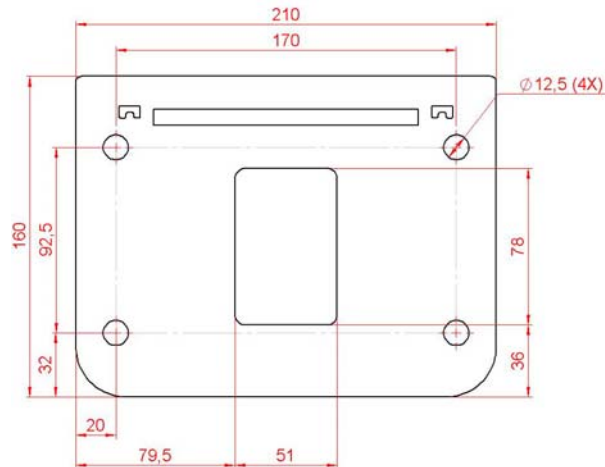

#### NOTE

The central slit is for the cable output , and the cables must be dimensioned according to the size of the opening.

2. Clean the holes, removing drilling residues.
3. Place the outside of four anchor bolts in the holes. Leave approximately 25 mm of the anchor bolt protrude from the hole.

**NOTE**

We recommend the Tecart brand anchor bolts, model AF38110, 3/8x4".

4. Position the column and fasten it to the floor with the four bolts that come with the anchor bolts. Use a 3/4" socket wrench or articulated ratchet spanner.

**4.4 ARM ASSEMBLY**

After drilling the floor and installing the column, it is possible to assemble the arm and plastic covers.

Below is a sequence of instructions and figures to help assemble the CATRAX Clip arm. TURNSTILES recommends that at least two people carry out the assembly.

1. After unpacking and installing the CATRAX Clip, place the arm close to the front holes on the tube (central shaft). First fit the lower arm rod, then press the top rod for it to reach the respective hole.



2. Once the arm has both rods duly fitted, turn the arm to one side up to approximately 180 degrees or until it reaches the end of its travel. You will notice there are two holes on the back part of the tube.





3. Use a # 5 Allen wrench to fasten the arms to the holes using the bolts and washers that come with the product.



4. The following figures show the CATRAX Clip with the arm assembled and fastened (position zero and end of travel).

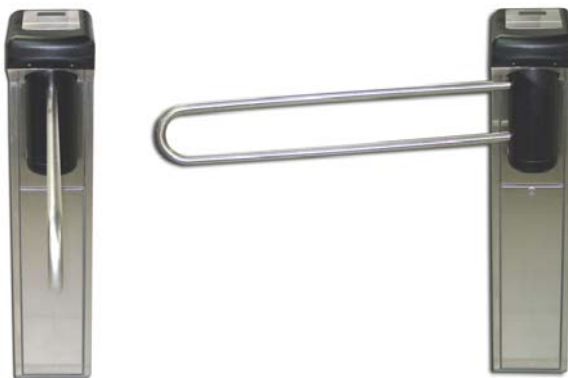

#### **4.5 ACCESS TO THE CATRAX CLIP AFTER ASSEMBLY**

After the CATRAX Clip has been installed and assembled, access to the inside of the equipment is possible using the key that comes with the equipment in three ways:

- rear cover;
- front cover;
- column door.

## **5 INSTALLATION/ASSEMBLY OF OPTIONAL ITEMS**

---

Although it is compatible with the majority of the access control technologies currently available, Digicon also offers several optional items that allow for improving and adapting the operation of the CATRAX Clip to customer needs. Below are descriptions for each one of these items.

### **5.1 DEPOSIT KIT WITH URN**

The deposit kit with urn features a card or tag collection, retention and retrieval device. Ideally suited for places that receive eventual visitors or users. The kit has a spout, a solenoid-activated retention device and a storage urn. The following figure shows the items that come with the deposit kit and may serve as a guide for its assembly.



**5.1.1 Connecting the deposit kit to the control board**

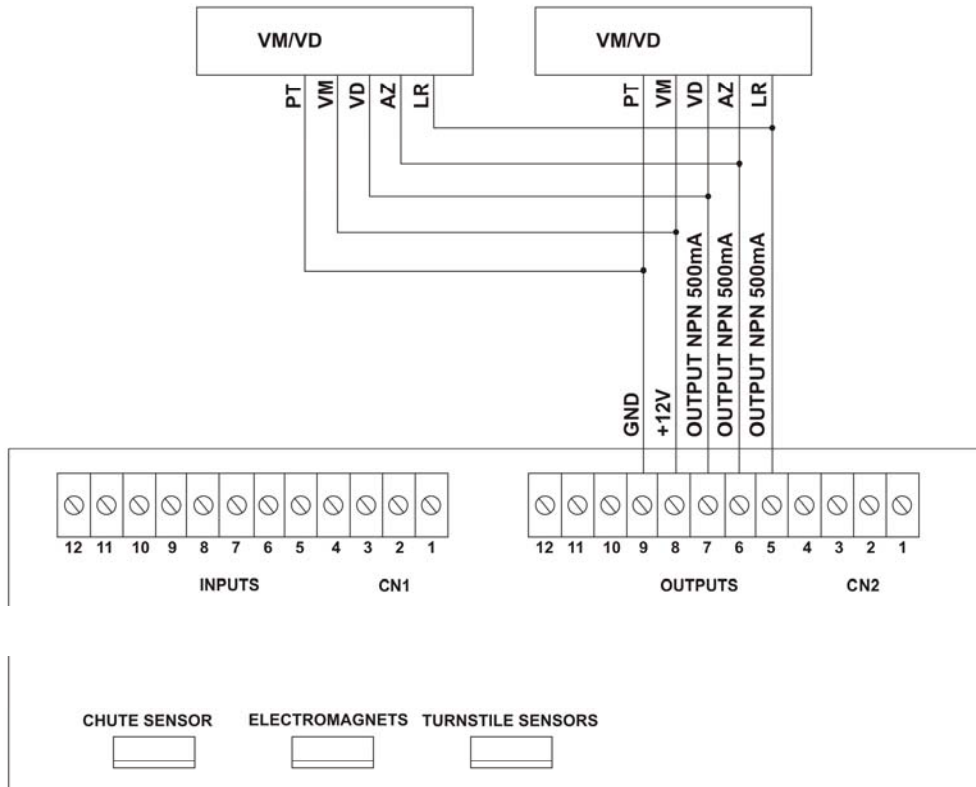

**NOTES**

- The urn for the cars is part of the kit and is positioned below the deposit kit.
- The tag reader is not part of the kit.

## 5.2 PICTOGRAM KIT

The pictogram kit visually signals when the passage is allowed (green color), and when it is blocked (red color). The pictogram is installed on the front part of the plastic cover.

Detail of pictogram



## 5.3 POWER SUPPLY

This power supply was especially designed for the CATRAX line. Among the main advantages of this optional item is its ability to adapt to voltage variations that are common in many installation sites – the input voltage may vary between 90 and 250 VAC.

The technical characteristics, protections and specific dimensions of this power supply were thoroughly tested and approved under the most adverse environmental and temperature conditions, which ensures an appropriate supply for equipment operation. On top of the input and output voltages indicated in the figure below, the power supply is also protected against short circuits and overheating.

Input (85 a 250 VAC)

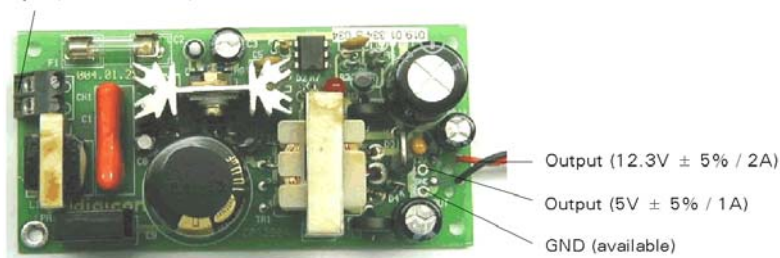

### NOTE

The power supply can be fastened to the board mounting rack provided with the CATRAX Clip.

### ATTENTION

The supply does not have a ground cable input. Grounding is to be made directly on the ratchet casing using the board mounting rack fastening bolt.

## 5.4 CONTROL BOARD

The CATRAX Clip control board was designed to meet the needs of the majority of currently available access control technologies. The controller features three mechanical characteristics and layout perfectly suited to the CATRAX Clip needs, and is one of the best options for equipment operation.

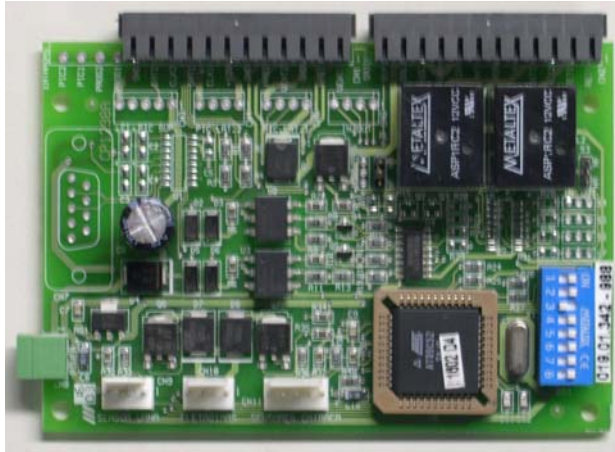

The table below describes the functions of the control board connectors.

Signal	Name/Description
<b>CN1</b>	<b>INPUTS</b>
1	+Vext1 (to enable passage by tension)
2	HAB1 (right to left direction)
3	GND
4	Vext2 (to enable passage by tension)
5	HAB2 (left to right direction)
6	GND
7	+12VDC (available for auxiliary – maximum of 500 mA)
8	CLOCK1 (input for reader, left to right direction)
9	DATA1 (input for reader, left to right direction)
10	CLOCK2 (input for reader, right to left direction)
11	DATA2 (input for reader, right to left direction)
12	GND
<b>CN2</b>	<b>OUTPUTS</b>
1	NA or NF contact (HAB1 return)
2	C contact (HAB1 return)
3	NO or NC contact (HAB2 return)
4	C contact (HAB2 return)
5	Output for X indicator (NPN open collector – maximum 500 mA) – orange wire
6	Output for → arrow (NPN open collector – maximum 500 mA) – blue wire
7	Output for ← arrow (NPN open collector – maximum 500 mA) – green wire
8	+12VDC (power for indicator arrows) – red wire
9	GND (power for indicator arrows) – black wire
10	+ tag collector urn solenoid
11	- tag collector urn solenoid
12	audible signal (open collector - NPN)
<b>CN8</b>	<b>POWER – Power input</b>
1	+12VDC power input
2	GND power input
<b>CN9</b>	<b>URN SENSOR</b>
1	LED anode
2	Urn signal
3	GND
4	GND
<b>CN10</b>	<b>ELECTROMAGNETS</b>
1	+ electromagnet 1
2	- electromagnet 1
3	+ electromagnet 2
4	- electromagnet 2
<b>CN11</b>	<b>OPTICAL SENSORS</b>
1	Sensor signal 1
2	LED 1 anode
3	Sensor signal 2
4	GND
5	LED 2 anode

**NOTES**

- Optical sensor (CN11) and electromagnet (CN10) cables are supplied with the CATRAX Clip.
- The urn sensor (CN4) cable is supplied with the deposit kit (optional).

**5.4.1 Inputs**

The input and passage enabling (HAB1 and HAB2) signals can originate from relay contact, pushbutton, or 5 to 24 VAC/DC or 110 to 220 VAC/DC voltages.

To enable the passage through relay contact or pushbutton, make the connection according to the figure below:

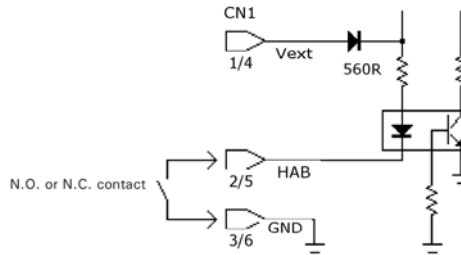

Passage enabling through voltage pulse is shown in the following figure. Follow the polarity for DC voltages and use an external resistor for high voltages (110 to 220 V).

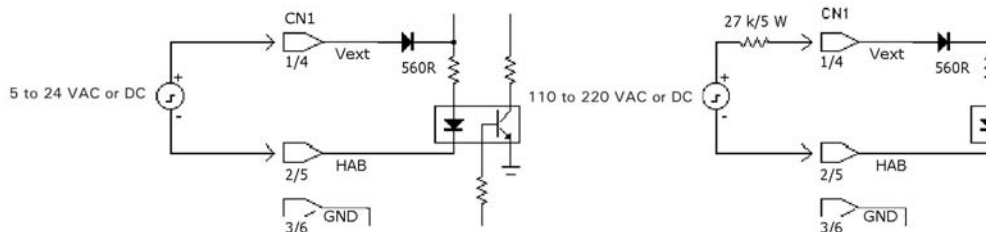

The control board also has inputs for optical sensors (CN11) that monitor CATRAX Clip turning (no mechanical wear), and two opto-insulated inputs to release the CATRAX Clip if needed.

**5.4.2 Outputs**

The CATRAX Clip board features outputs for return signals, electromagnets, pictograms, deposit box, and audible alarm.

*5.4.2.1 Return signals*

The return signals indicate the moment and the direction of passage and are originated at a relay – normally open (NO), or normally closed (NC) contact. Connect the outputs according to the figure below.

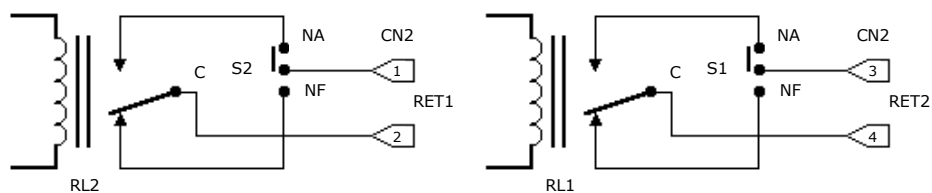

#### 5.4.2.2 Electromagnets

The electromagnets are activated to block the passage. Unlike traditional solenoids, electromagnets do not cause friction between the spool and the locking device, preventing malfunction problems. Also, activation is done through a transistor, not a relay, preventing burning the electromagnets due to "contact binding" (no mechanical wear).

#### 5.4.2.3 Audible alarm

The audible alarm output is activated by an NPN transistor (maximum 500 mA) whenever the CATRAX Clip:

- receives a release signal (two brief beeps);
- has not been released and is forced for 1 second (1 second beeps);
- stops in the middle of a turn for more than 2 seconds (1 second beeps).

Connect the outputs according to the figure below.

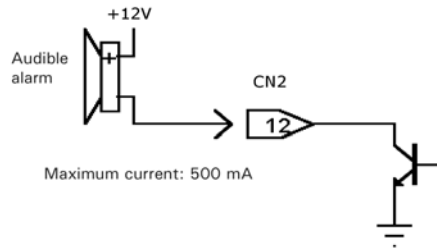

#### 5.4.2.4 Connection schematics

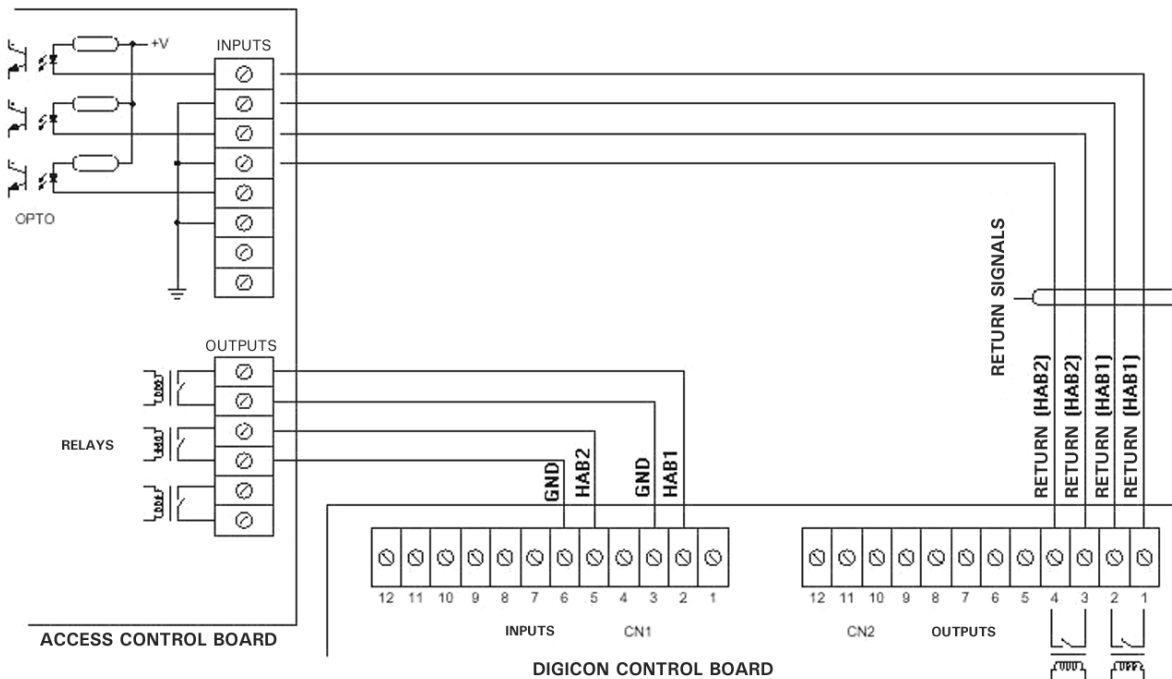

#### 5.4.2.5 Pictogram

Pictogram outputs are activated by NPN transistors (maximum 500 mA). On activation, GND is sent through the corresponding output.

#### 5.4.2.6 Pictogram connections

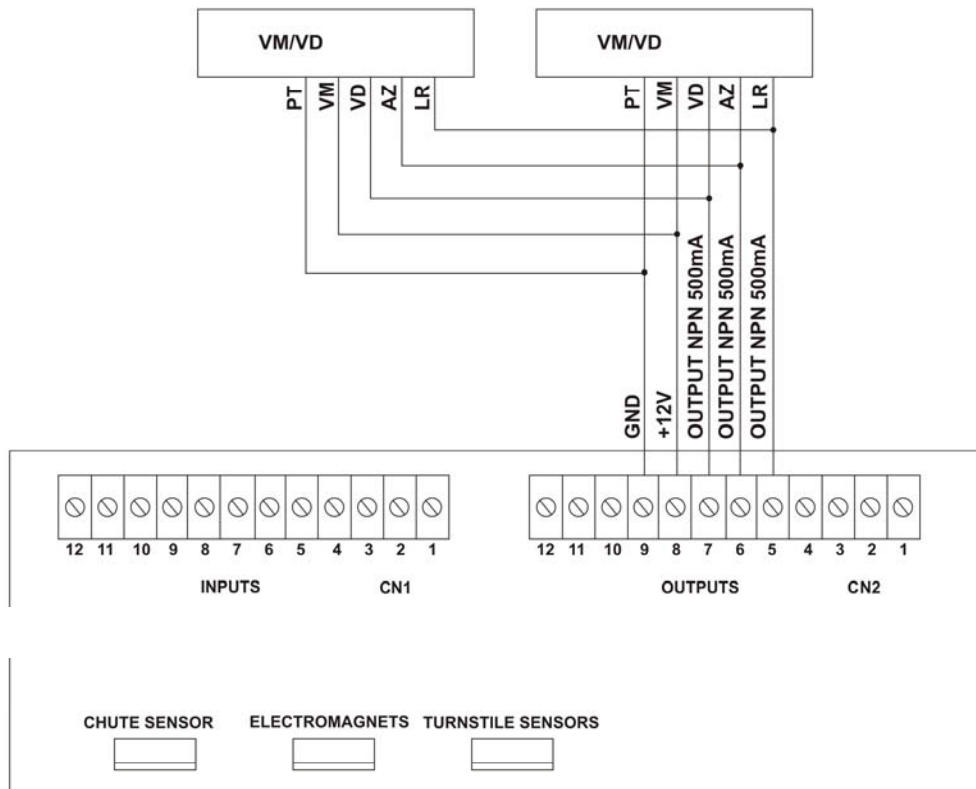

#### 5.4.3 Control board configuration – Dip Switch DS1

DS1 dip switch is used to configure the following actions:

- direction of passage;
- maximum passage time;
- NO inputs (normally open relay or pushbutton contacts without input voltage) to enable passage in the presence of these signals, or NC inputs (normally closed relay or pushbutton contacts with input voltage) to enable passage in the absence of these signals;
- enable an audible alarm signal if the access controller stops in mid turn for over 2 seconds.

To program the DS1, place each pin in the desired position according to the table below.

	01	02	03	04	05	06	07	08
Release both directions	-	-	-	OFF	OFF	-	-	-
Locked left to right direction	-	-	-	ON	OFF	-	-	-
Locked right to left direction	-	-	-	OFF	ON	-	-	-
Locked both directions	-	-	-	ON	ON	-	-	-



NO inputs	-	ON	-	-	-	-	-	-
NC inputs	-	OFF	-	-	-	-	-	-
Enable audible signal in mid turn	-	-	-	-	-	ON	-	-
Disable audible signal in mid turn	-	-	-	-	-	OFF	-	-
Wait for first turn	-	-	-	-	-	-	ON	ON
Hold for 5 seconds	-	-	-	-	-	-	OFF	ON
Hold for 10 seconds	-	-	-	-	-	-	ON	OFF
Hold for 15 seconds	-	-	-	-	-	-	OFF	OFF
Enable by edge	-	-	OFF	-	-	-	-	-
Enable by level	-	-	ON	-	-	-	-	-

#### NOTES

- The control board can be fastened to the mounting rack that comes with the CATRAX Clip.
- The shaded fields indicate the default configuration of the board.

#### 5.4.4 Examples of configurations

1 - Configuration of controller to receive on relay pulse (normally open contact), release turn the hold the passage for 10 seconds:

	1	2	3	4	5	6	7	8
Configuration	-	ON	OFF	ON	ON	-	ON	OFF

2 - Configuration of controller to leave the clockwise direction always released and, upon receiving the release signal at HAB2 (counter clockwise), release passage for indeterminate time.

	1	2	3	4	5	6	7	8
Configuration	-	ON	OFF	OFF	ON	-	ON	ON

3 - Configuration of the controller to release turn while the relay has a closed contact, and as soon as the relay contact opens remove the release.

	1	2	3	4	5	6	7	8
Configuration	-	ON	ON	ON	ON	-	ON	ON

## 6 MAINTENANCE

### 6.1 PREVENTIVE AND CORRECTIVE MAINTENANCE SCHEDULE

**Sphere base – Frequency: every 700,000 cycles**

Check the sphere tracks for wear.

Corrective actions:

1. If there is excessive wear (shards, perforations, steel filings or grooves where the sphere runs), replace the part.
2. If the part does not show wear signs, clean and grease it using bearing grease.



### **Optical sensors – Frequency: at least once a year (depending on environmental conditions)**

This maintenance procedure requires the use of a multimeter. To check for the need of corrective actions, it is necessary to measure the CN11 when the controller is powered, according to the instructions below:

- Set the multimeter to measure DC voltage of up to 20 V. Next, place the black pointer on pin 4 and the red pointer on pin 1 on CN11. Voltage should be under 0.8 V (non-obstructed sensors). With the pointers in the same position, force the equipment arm on both sides (on one side the voltage should be higher than 4.5 V).
- Repeat the operation in the previous placing the black pointer on pin 4 and the red pointer on pin 3 on CN11. The results obtained should be the same as those on pins 4 and 1.
- Check the sensors for signs of dust.

Corrective actions:

1. If the measurements do not match the results above, replace the faulty sensor.
2. Clean the sensors with a clean brush.

#### **NOTE**

In excessively dusty environments, perform this maintenance procedure more frequently.

### **Electromagnets - Frequency: every 700,000 cycles**

This maintenance procedure requires the use of a multimeter. To check for the need of corrective actions, disconnect the CN10 from the access controller board and check electromagnet resistance. The value should be between 12.5 and 13.5 ohms on pins 1, 2, 3, and 4 of the electromagnet connector. After measuring, reconnect CN10 to the board.

Corrective actions:

1. Replace the electromagnet if incorrect resistance, electromagnet in short or open circuit is observed.
2. If the electromagnet is not working, check the board and the voltage.
3. If the electromagnet is moving, tighten the base bolts.

Electromagnet adjustment (if necessary):

1. Force the lock against the sprocket and the equipment arm until the lock is totally inside the first tooth (until the arm locks).
2. Next, release the fastening bolts and press the electromagnet against the lock buffer so that all its area contacts the electromagnet.
3. Retighten the bolts.

### **Lock assembly – Frequency: every 700,000 cycles**

To check for the need of corrective actions, you should:

- Check the correct lock position.
- Check the lock fitting to the sprocket for wear.

Corrective actions:

1. If the lock is incorrectly positioned, check the retention ring and the spring that tensions the assembly.
2. If the lock fitting to the sprocket is incorrect, replace the lock or the sprocket.
3. If there are signs of wear on the lock end, replace the lock.

### Sprocket assembly – Frequency: every 700,000 cycles

To check for the need of corrective actions, you should:

- Check the sprocket teeth for wear.
- Check the clearance between the central shaft, the sprocket and the cotter pin.

Corrective actions:

1. If you observe any signs of wear on the part teeth replace the sprocket.
2. If you notice excess clearance between the sprocket and the shaft/cotter pin assembly, replace the sprocket or the cotter pin (to change the sprocket, use a pulley extractor).

## 6.2 TROUBLESHOOTING

Defect	Likely causes	Action
<ul style="list-style-type: none"> <li>• CATRAX Clip will not go on</li> </ul>	<ul style="list-style-type: none"> <li>• Power supply cable is not connected properly.</li> <li>• Power supply fuse is burnt.</li> </ul>	<ul style="list-style-type: none"> <li>• Check the wiring and the fuse (fuse: 3 A).</li> </ul>
<ul style="list-style-type: none"> <li>• CATRAX Plus is locked</li> </ul>	<ul style="list-style-type: none"> <li>• Optical sensors are obstructed or defective.</li> </ul>	<ul style="list-style-type: none"> <li>• Carry out preventive maintenance procedures in the sensors or send the equipment to Technical Assistance.</li> </ul>
<ul style="list-style-type: none"> <li>• CATRAX Plus will not activate electromagnet (always released)</li> </ul>	<ul style="list-style-type: none"> <li>• The cable is broken or the distance between the electromagnet and the lock device is out of adjustment.</li> </ul>	<ul style="list-style-type: none"> <li>• Adjust the electromagnet or send the equipment to Technical Assistance.</li> </ul>
<ul style="list-style-type: none"> <li>• Arm will not stay in the correct position</li> </ul>	<ul style="list-style-type: none"> <li>• The sphere base is worn, dirty, has a broken spring or lacks lubrication.</li> </ul>	<ul style="list-style-type: none"> <li>• Request replacement of the defective part or send the equipment to Technical Assistance.</li> </ul>
<ul style="list-style-type: none"> <li>• CATRAX Plus will not lock on the first tooth.</li> </ul>	<ul style="list-style-type: none"> <li>• The distance between the electromagnet and the locking device is out of adjustment.</li> </ul>	<ul style="list-style-type: none"> <li>• Adjust the electromagnet or send the equipment to Technical Assistance.</li> </ul>

## 7 TECHNICAL CHARACTERISTICS

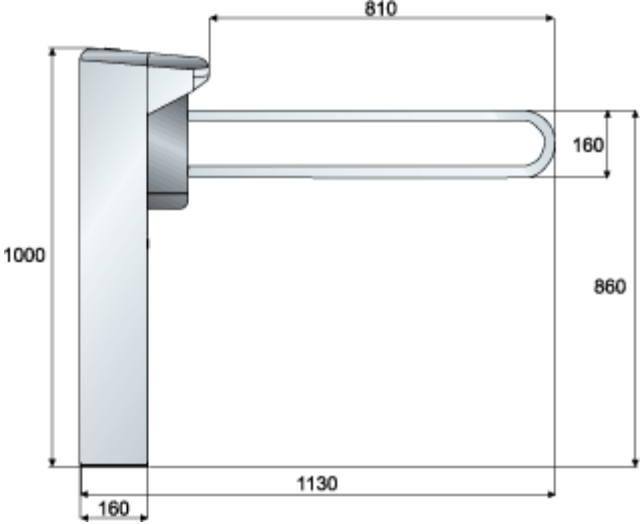
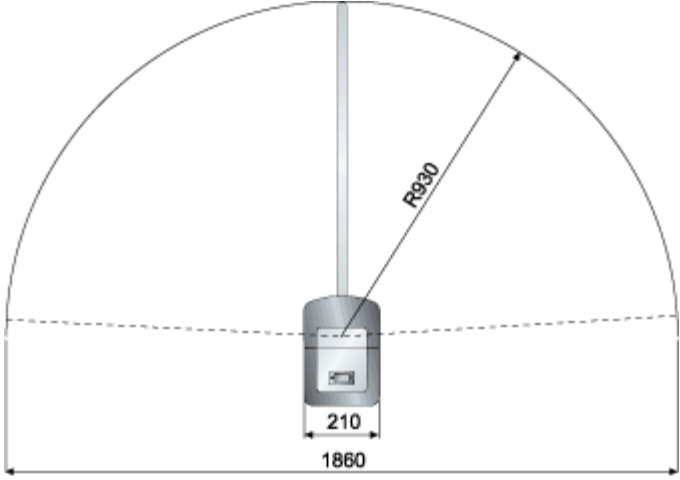
<b>Dimensions</b>	
Side view:	
Top view:	
Packaging:	Height: 103 cm Width: 27 cm Depth: 55 cm
<b>Other information</b>	
Gross weight:	37 kg (+ 2 kg of packaging)
Electromagnet power supply:	12 V and 2 A
Sensor power supply:	5 V and 0.5 A
Power supply (optional)	Input: 85 V to 250 VAC Output: 12.3 V ± 5% / 2 A, and 5 V ± 5% / 1 A Dimensions: 35 x 51 x 105 mm Distance between holes: 43 x 98 mm Hole diameter: 3.5 mm