

mTripod

Pivoting Tripod turnstile

TURNSTILES.us



Extensive functions and intuitive operation

These exceptional pedestrian gates can be controlled with all common reading devices. The front faces allow installation of numerous card-reading models, ensuring maximum flexibility. The product is characterized by an extremely slender silhouette, shapely form and flowing lines.

The lean design harmonically integrates itself in architecturally demanding surroundings, and its inviting shape increases user acceptance.

The housing consists of a specially developed two-component polymer. This material opens up previously impossible design potentials.

Unlike stainless steel, our material is not cold and hard but instead feels comfortably warm and nice to touch. A friendly reception for visitors is thus provided on entering the building.



Unobstructed escape routes

FlowMotion® gates provide free passage if there is a power outage or alarm signal. They automatically resume operation when the alarm is over or power has been restored.



Large visitor numbers

It makes sense to use several parallel lines if large numbers of visitor authorizations need confirmation within a very short time. All FlowMotion® pedestrian gates are suitable for the straightforward setting up of multiple applications thanks to their uniform stylistic language and control technology.

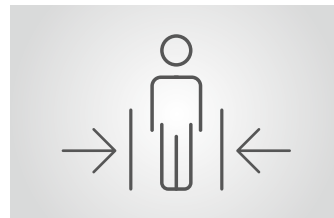

Secure access control

Light sensors (optional) raise the alarm if someone climbs over or crawls under the pedestrian gates. Interlocking in the closed state (optional) prevents any forced entry.

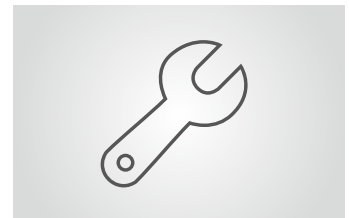

Rapid installation

Our pedestrian gates are supplied ready for installation. All the selected options have already been installed, and the corresponding parameters preset, before delivery to the point of use. This, and the drilling templates, considerably shorten commissioning times.

mTripod

Pivoting tripod turnstile



- > Revolutionary design, won Design Award 2018
- > Extensive functions and intuitive operation
- > Drop-arm mechanism (optional) permits passage during power outages or alarms
- > Ethernet plug-in module for IP connection (optional)
- > Designed for more than 10 million opening and closing cycles



Technical data	mTripod	mTripod short
Housing variants	Long	Short
Application	Indoor and outdoor	Indoor and outdoor
Passage width (to end of arm)	20.3 inches	20.3 inches
Flow ratings (number of persons per min.) ¹	approx. 20	approx. 20
Drive technology	MHTM™	MHTM™
Control system	MGC	MGC
Voltage	100 – 240 V AC, 50/60 Hz	100 – 240 V AC, 50/60 Hz
Power consumption	Typical 30 W	Typical 30 W
Duty cycle	100%	100%
Housing material	mDure	mDure
Housing dimensions (L x W x H)	51.2 x 11.4 x 41.3 inches	28.7 x 11.4 x 41.3 inches
Enclosure rating	IP 54	IP 54
Weight	About 154 lbs.	About 126 lbs.
Temperature range	-22 to +131 °F	-22 to +131 °F

¹ Depending on reader, lock setting, person behaviour

Features	
Direction of passage	Uni- or bi-directional
Emergency release	On power outage or closing of alarm contacts
Random generator	Integrated in control system
Throughput data acquisition and event log	Integrated in control system
Control system inputs and outputs	8 digital inputs, 4 digital outputs, and 6 relay outputs

Standard colours	
	
Basalt (similar to RAL 9006)	Anthracite (similar to RAL 9005)

Potential applications	
	

Dimensional drawings

mTripod – side view

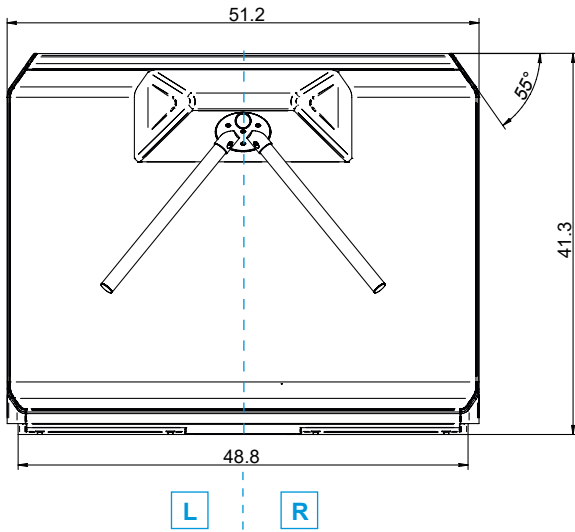

mTripod short – side view

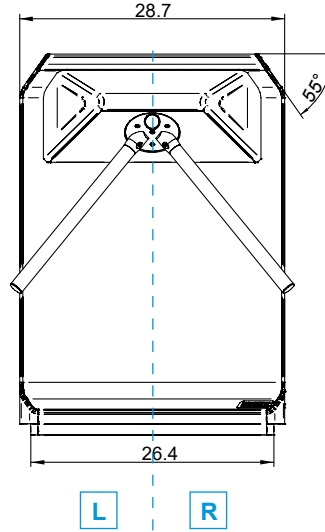

You can obtain options as left **L** or right **R** versions. If you look at the mTripod from the tip of the turnstile bar the option is on the left with the left version and on the right with the right version.

mTripod – top view

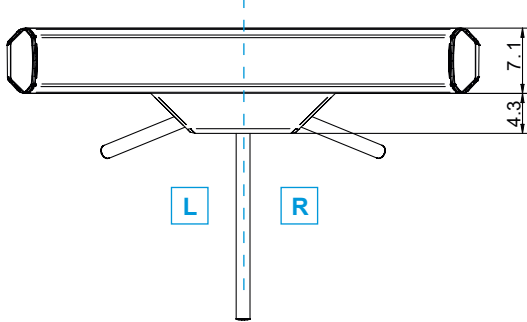

mTripod short – top view

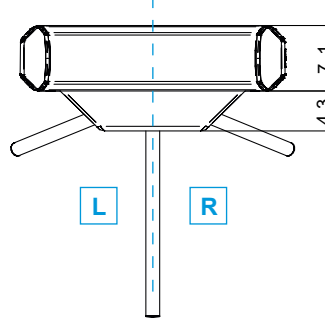

mTripod – front view

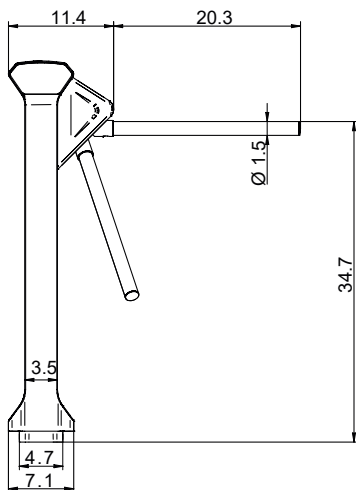

mTripod short – front view

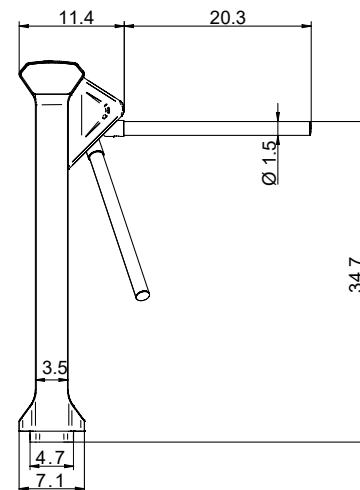

Mounting space for reading devices for mTripod and mTripod short (without passage indicator, mounting depth 1.6 inch)

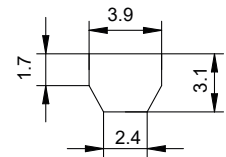

Subject to technical modifications.