

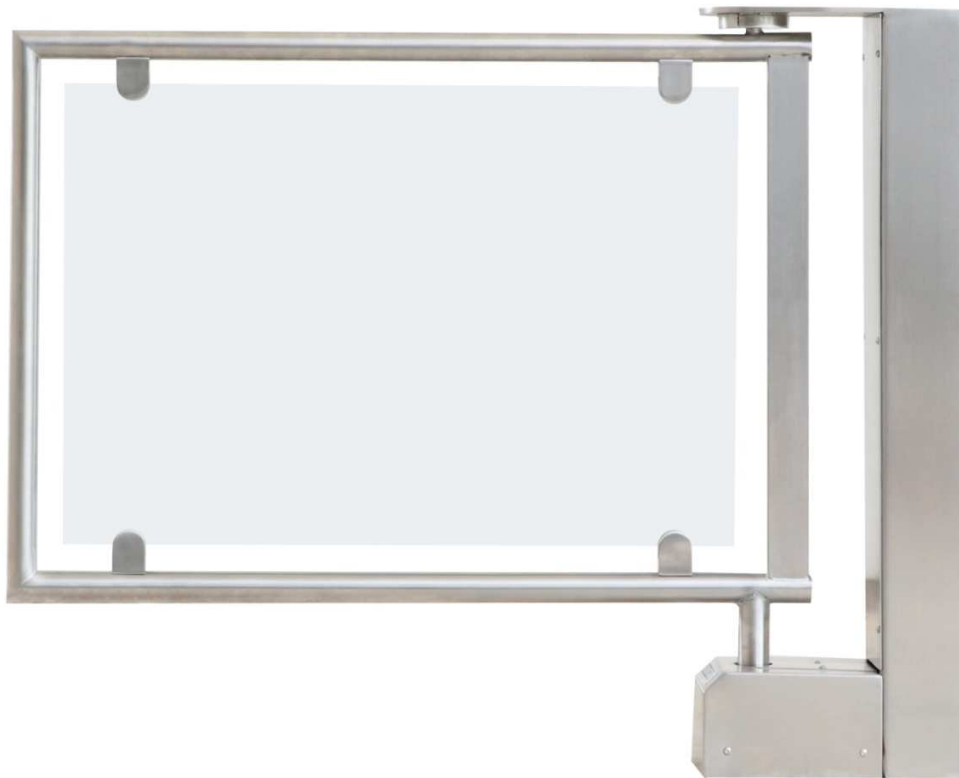

User Manual



SPECIAL NEEDS GATE

Semi-Automatic

CONTENTS

1. COPYRIGHT & LIABILITY.....	3
2. SAFETY	4
3. DATASHEET.....	4
4. INTRODUCTION.....	5
5. INSTALLATION	7
6. TYPICAL ARRANGEMENTS	9
7. READERS.....	11
8. FUNCTIONS.....	12
9. WIRING CONNECTIONS	14
10. CHECKLIST	17
11. MAINTENANCE.....	18
12. PARTS & WARRANTY.....	18

1. COPYRIGHT & LIABILITY

No part of this module may be reproduced in any form, photocopy or otherwise, without the written permission of the copyright holder.

All information, drawings and diagrams may not be made public or shared with a third party.

In the event of any breach of above mentioned copyright, the rights of the copyright holder will be strictly enforced.

This product may need to undergo a yearly service to assure optimum performance. This service may only be carried out by an approved agent.

Any guarantee on this product will expire should an unapproved person attempt to carry out a service. This product guarantee is only valid if the assembly is to manufacturer specification, as described in this manual, and providing the product functions as is expected under standard operating conditions.

2. SAFETY

During Maintenance:

- Avoid contact with moving parts.
- Ensure power supply is off.

During Operation:

- Children and minors must be accompanied and supervised.

3. DATASHEET

Mechanical:	Electro-magnetic Solenoid locking action Plastic Maintenance-free bearing arrangement Hydraulic Floor Spring door closer
Glass:	6mm thick Clear Toughened Glass (Framed version) / 12mm Clear Toughened Glass (Frameless version)
Frame:	Stainless Steel, grade 304 / 316, brushed Powder-coated Mild steel
Function:	90 degree plus, 90 degree minus (180 degree) operation 6 pedestrian throughput per minute Single passage, bi-directional, adjustable to be unidirectional (90 degree only operation) Door closer, hold open / non-hold open (optional)
Power requirement:	220V AC, 50Hz, 3A single phase live + neutral + earth Solenoid & Control Board optional power backup, 24V 7Ah sealed wet batteries Optional: 110 V AC, 50Hz, 3A single phase live + neutral + earth
Weight:	38kg estimated (without packing materials)

4. INTRODUCTION

The Special Needs Gate is a semi-automatic gate unit that unlocks electronically and returns to locking position mechanically.

The Special Needs Gate is primarily designed for wheelchair access, but it is used extensively by health clubs and also goods delivery.

The Special Needs Gate is designed for interior installations and exterior installations which are covered by a roof.

Applications: Office reception areas, health clubs, colleges, libraries, leisure parks and any application requiring a low volume of access for disabled, trolley and wheelchair access.

The following finishes are available:

- 304 grade brushed stainless steel
- 316 grade brushed stainless steel *
- Powder coated mild steel

(*) Suitable for exterior covered coastal installations (within 50km from the coast)

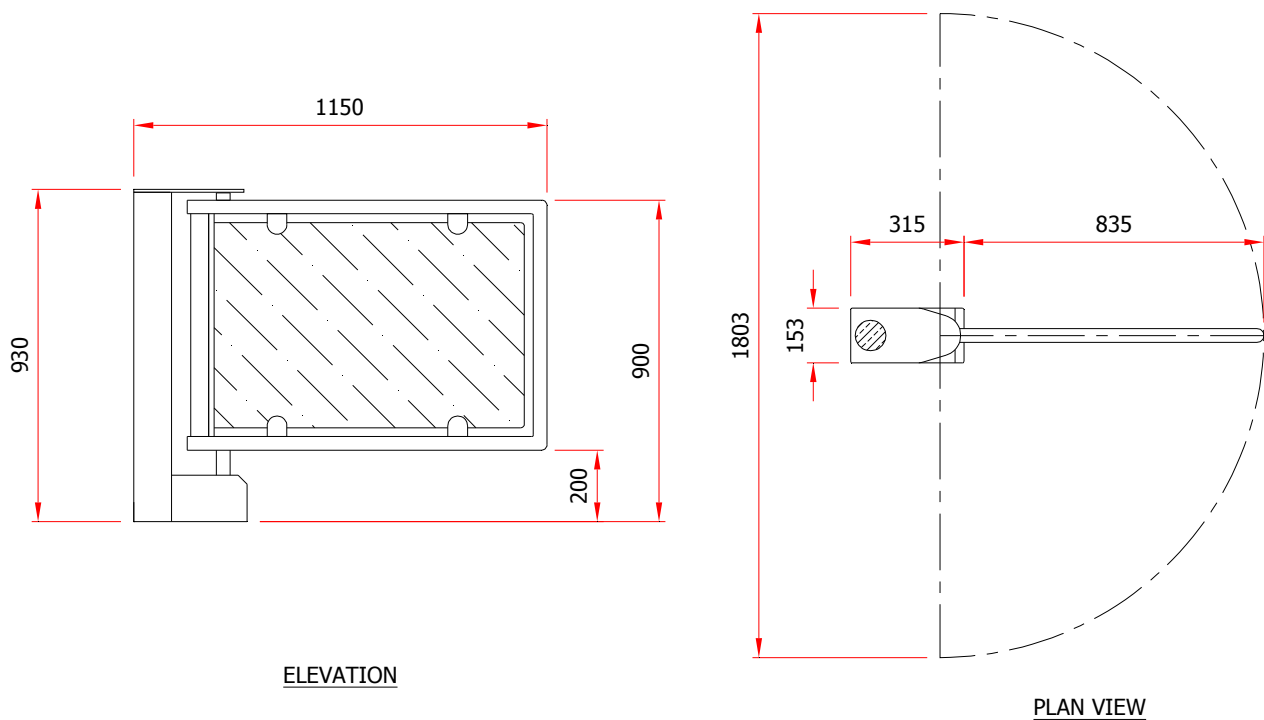

Figure 4A: Framed glass & stainless steel frame Option

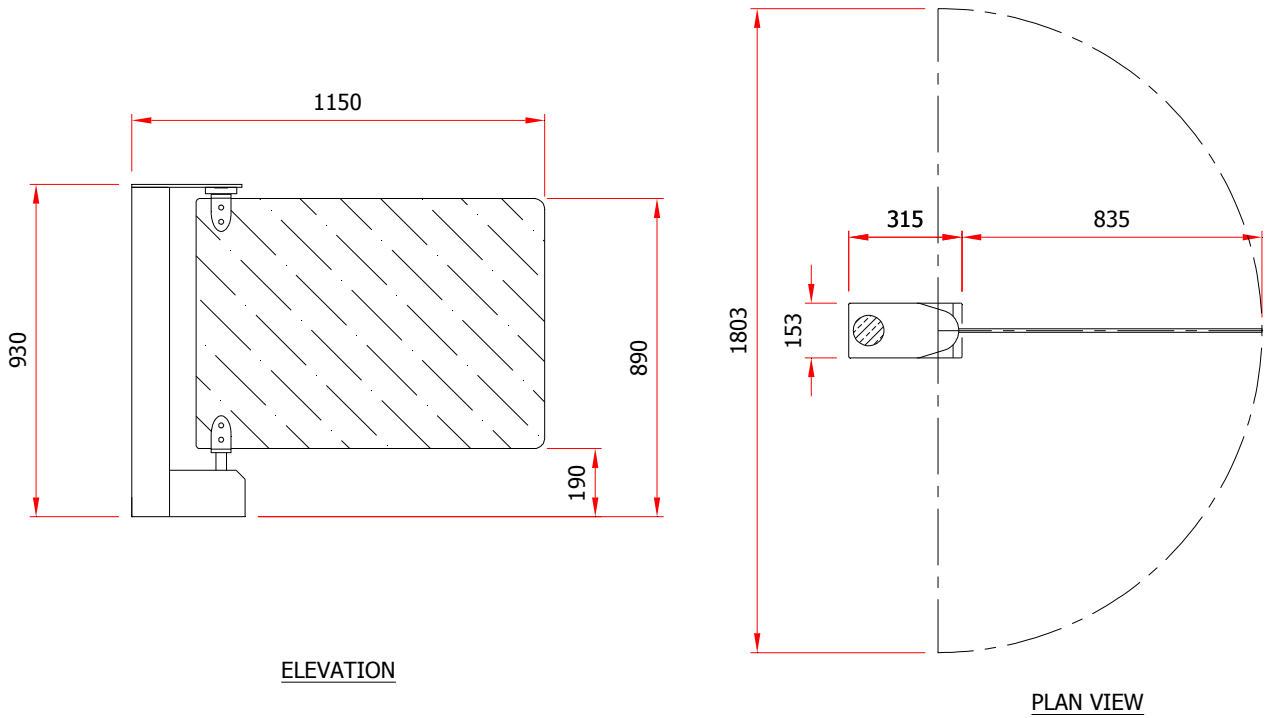

Figure 4B: Frameless glass panel Option

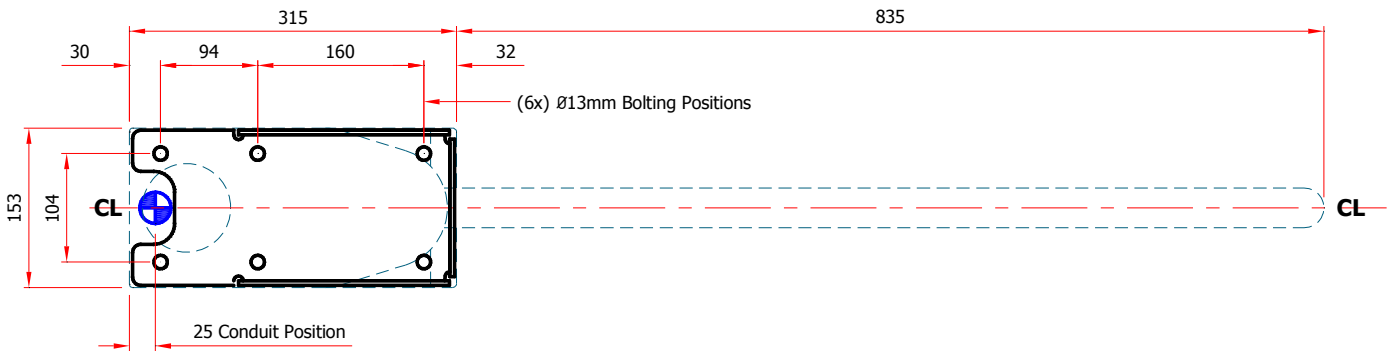

Figure 4C: Footprint & Shadow

5. INSTALLATION

Provision for the power and data cabling for the gate must be in place prior to installation. The gate is designed to be bolted directly onto the finished floor surface, e.g. tiles. The gate is bolted to the floor using M10x75 coach bolts with a nylon plug. The base will then be installed directly on the finished floor. Wiring for control and power are led from the floor, through the conduit point, to the control panel mounted inside the gate channel.

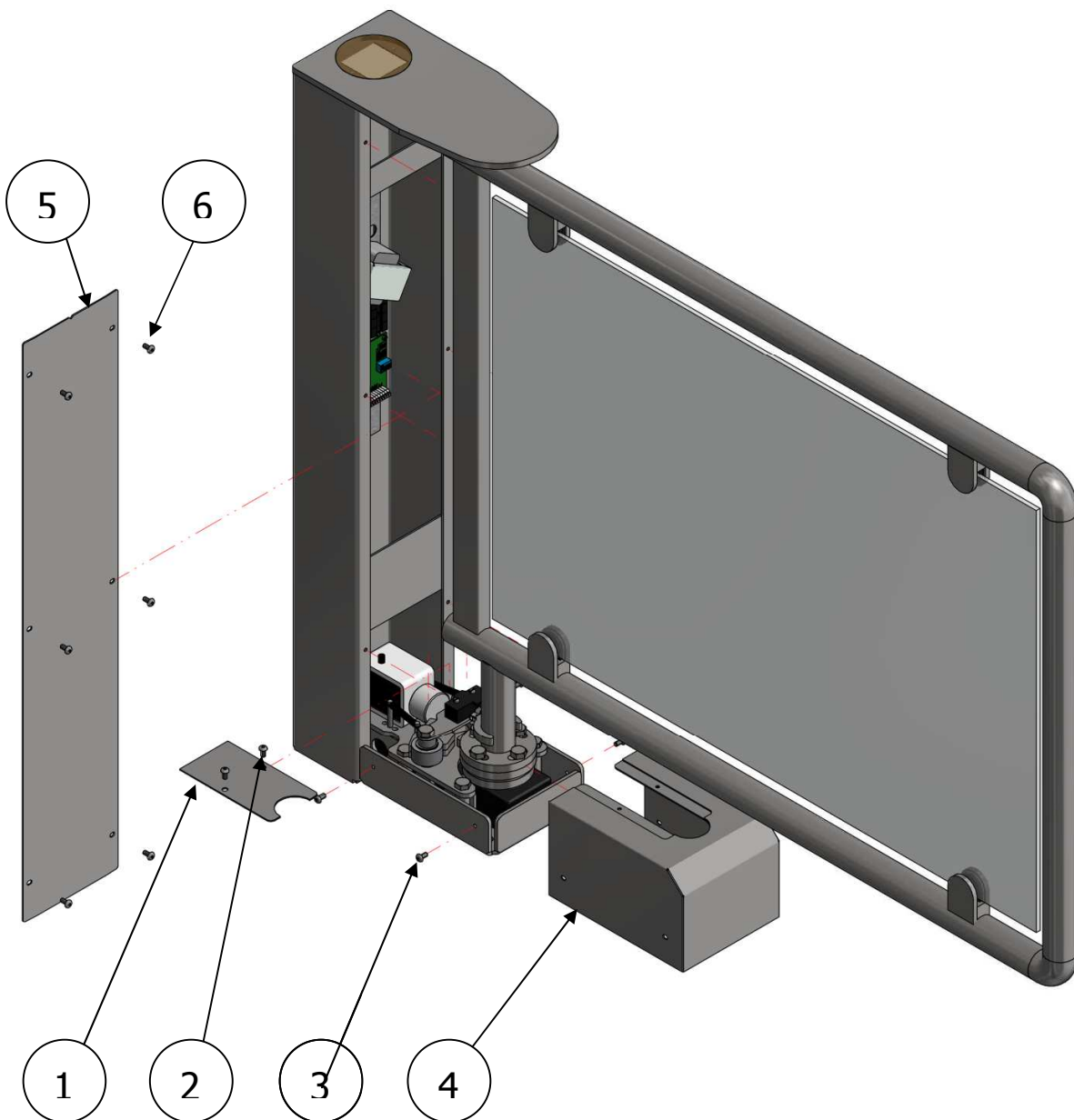

Figure 5A: Covers opening

To access the base plate for bolting the gate to the floor, first remove the finishing plate (1) by removing the two M5 button head screws (2) and lifting the plate. Next, remove the four M5 button head screws (3) from the sides of the mechanism cover (4) and slide the cover forward as shown.

To remove the channel cover (5), unscrew the six M5 button head screws (6). The base plate is now accessible to bolt to the floor.

Bolting points X are the required bolting holes and bolting points Y, are optional and can be used only when needed. Z indicates the conduit aperture area.

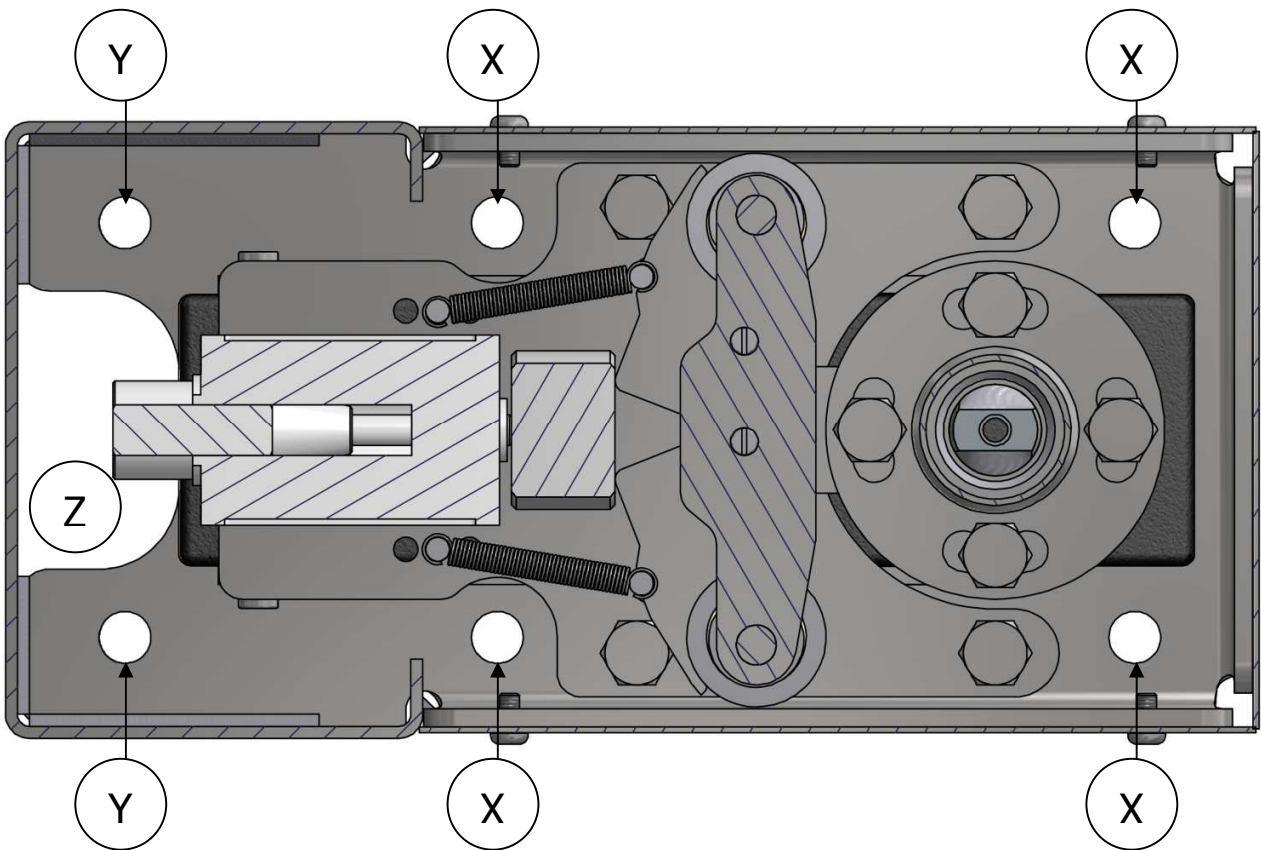

Figure 5B: Bolting Locations

6. TYPICAL ARRANGEMENTS

The Special Needs Gate can be installed next to a reception desk and turnstiles as shown. Normally, the reception will trigger the gate to allow access for special access. The opening clearance for access will be 835mm (approx). The gate can open +90 degrees or -90 degrees, making it 180 degree operation.

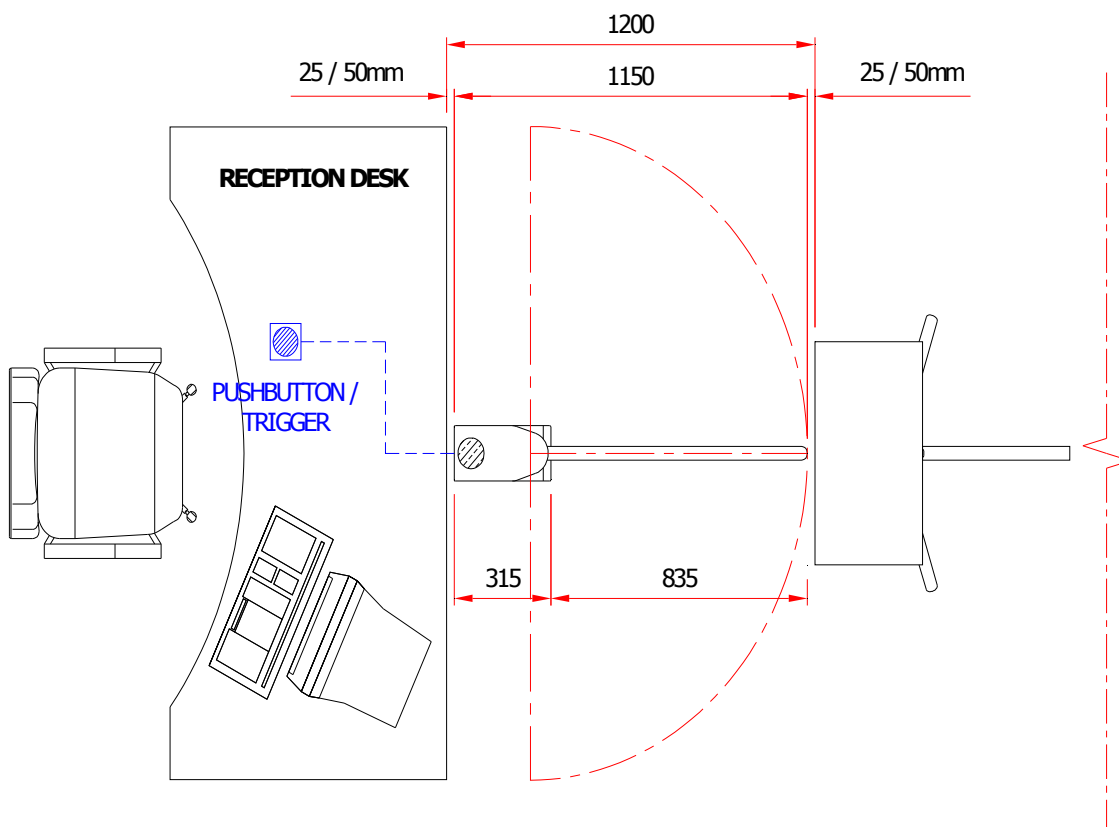

Figure 6A: Typical Reception Installation

The Special Needs Gate can also be installed in dual-arrangement, to form a larger opening passage.

The gate can be installed in passages with limited space. It can be configured to 90 degree only operation to fit into a passage of 1030mm width, while still providing recommended clearance for wheelchairs on opening.

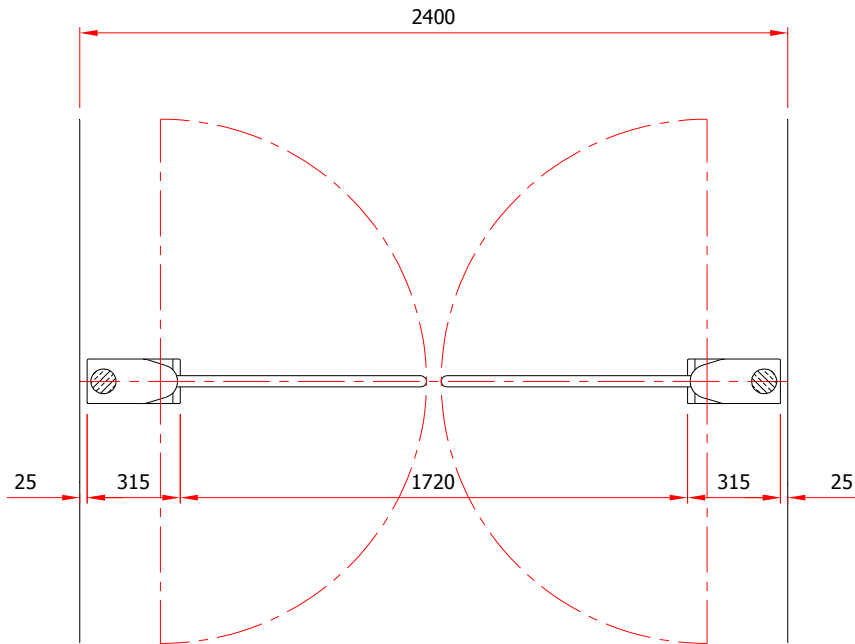

Figure 6B: Dual-arrangement

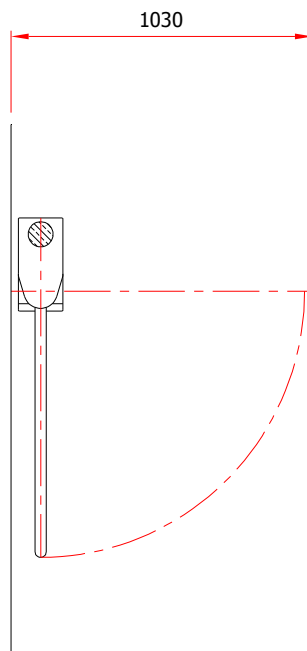

Figure 6C: Limited Passage, 90 degree installation

7. READERS

If a card reader unit or other trigger is to be installed for pedestrians, it should be mounted on a separate post next to the gate. The gate has no provision on the top for a reader.

Note: Turnstar does not supply card readers. An access control system with readers must be supplied by a third party.

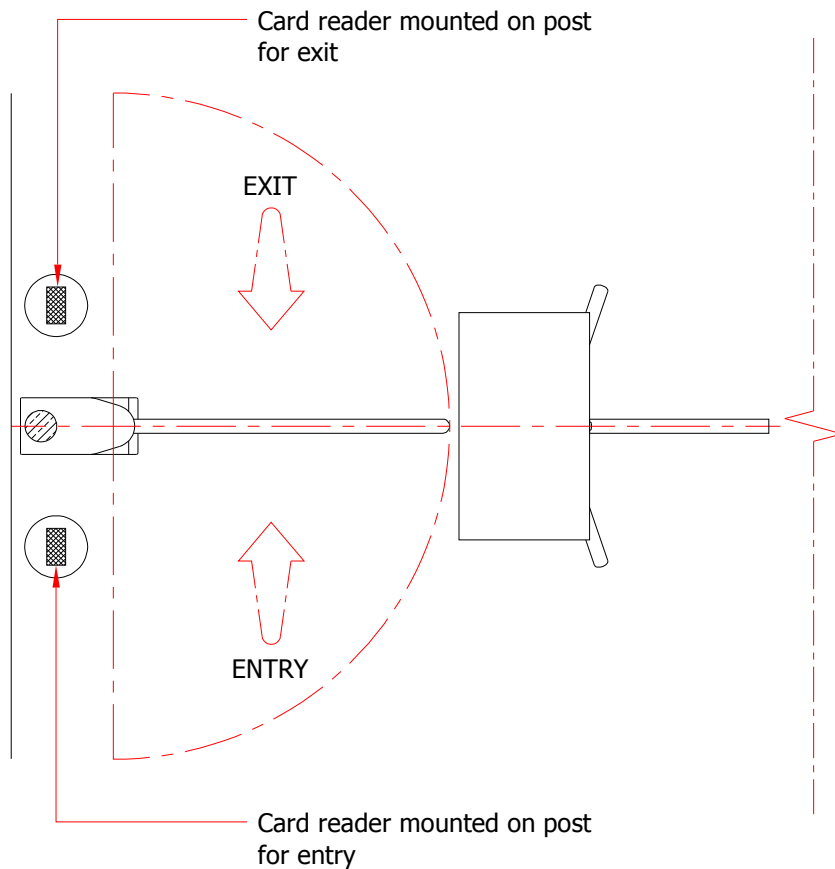

Figure 7A: Reader Mounting

8. FUNCTIONS

The mechanism is supplied only in fail-safe condition. This means that on power failure, the gate will unlock and allow free exit.

The mechanism is fitted with a floor-spring door closer. When triggered, the gate must be pushed or pulled open and will close automatically, and lock (under mains power).

The floor spring door closer is by default 'hold-open', which means that pushing it up to 90 degrees either plus or minus, the gate frame will stay open. To close the gate, move the gate frame to approximately 85 degrees and it will automatically close. This is useful for goods passage, when a trolley needs to pass through without the need for an assistant holding the gate open.

The gate is also available with a non-hold open door closer, however this is a factory setting and must be requested prior to dispatch.

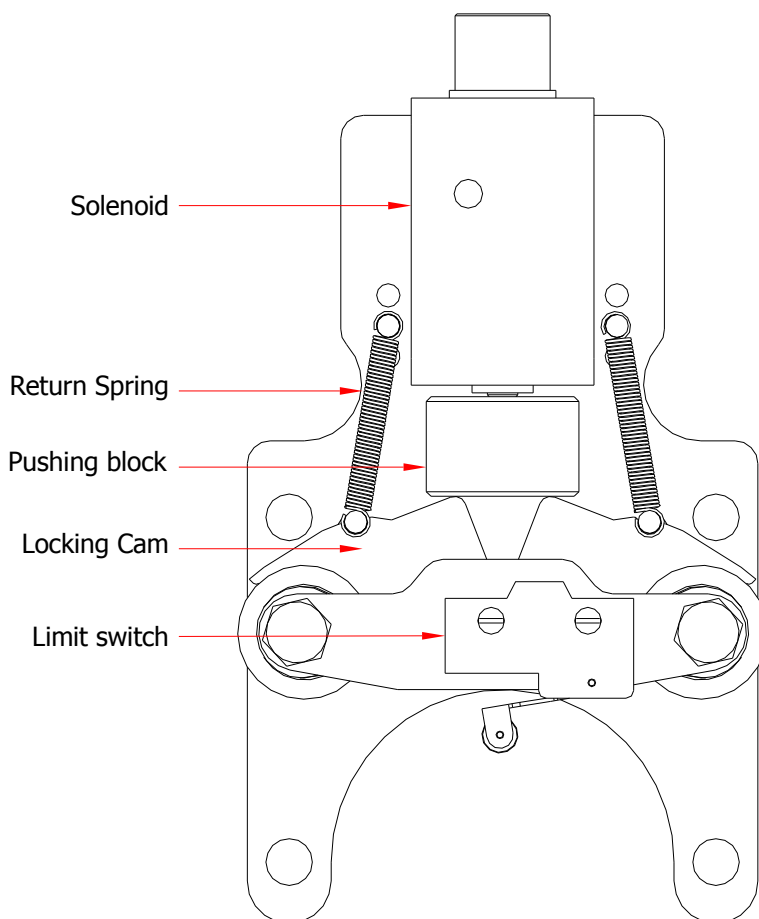
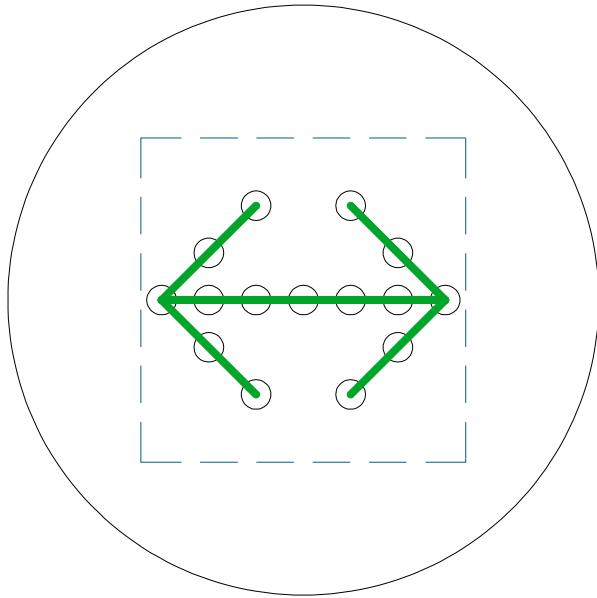
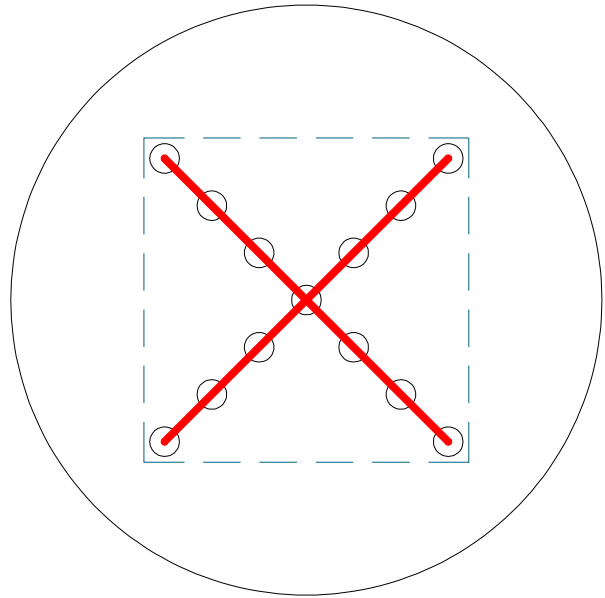

Figure 8A: Mechanism Parts

The LED directional indicator located on the top plate will show when the gate is unlocked or locked. The Green arrow LED will be active when the gate has received a valid trigger and will remain on until the gate returns to the locking position and the time-out expires.



Green Arrow LED



Red Cross LED

9. WIRING CONNECTIONS

The control panel is located inside the upright and can be accessed by removing the front cover.

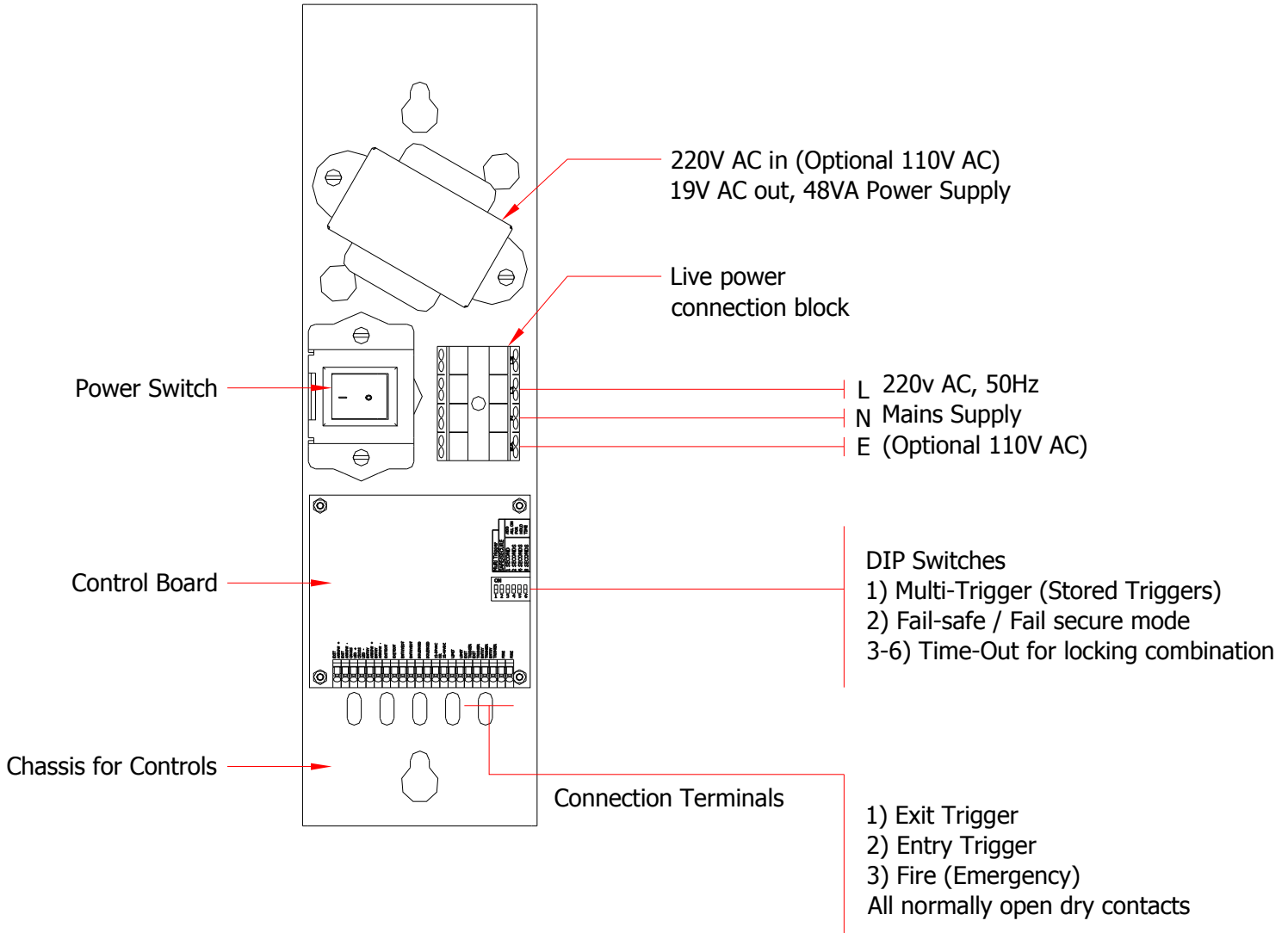

Figure 9A: Control Panel schematic

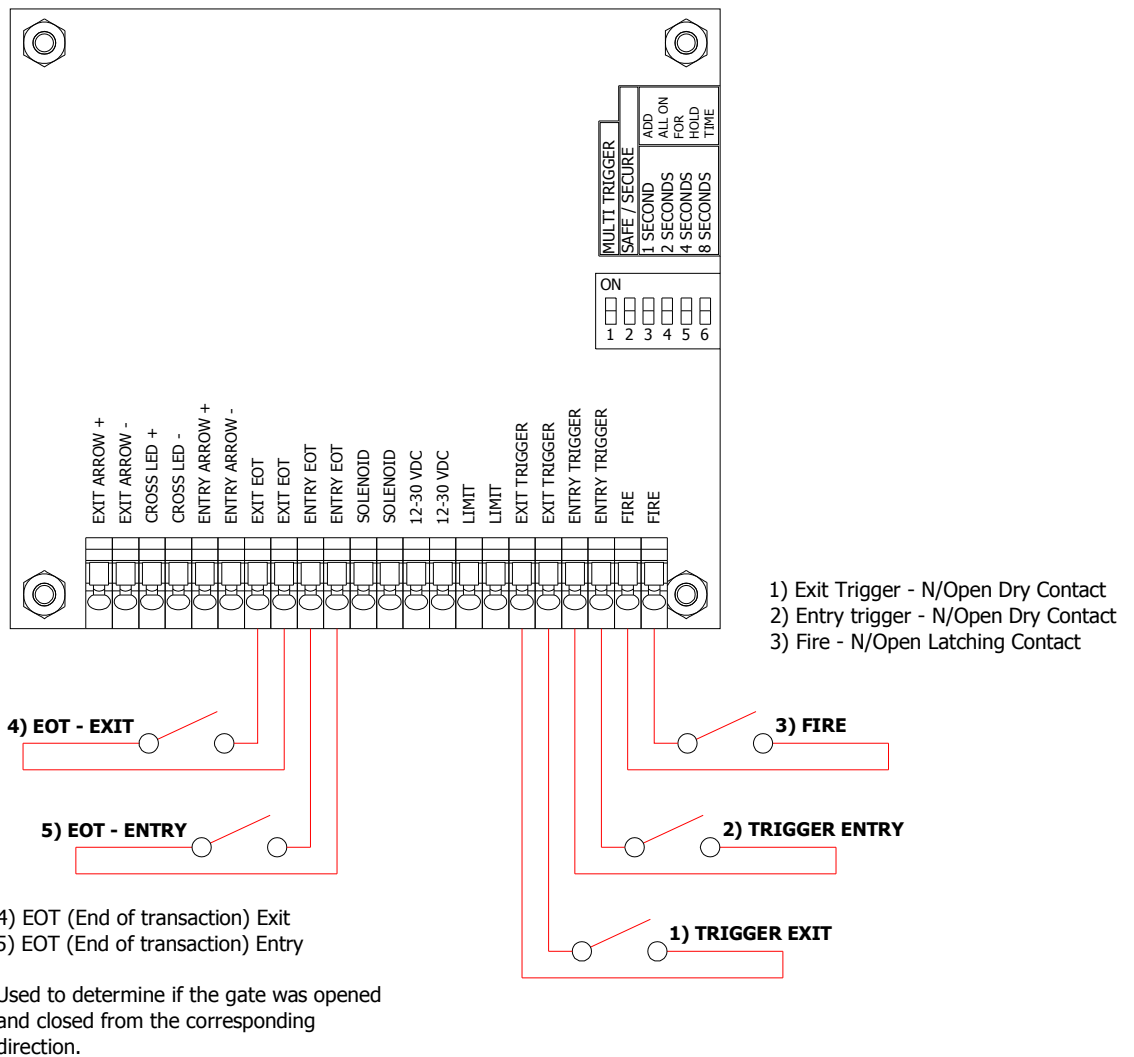
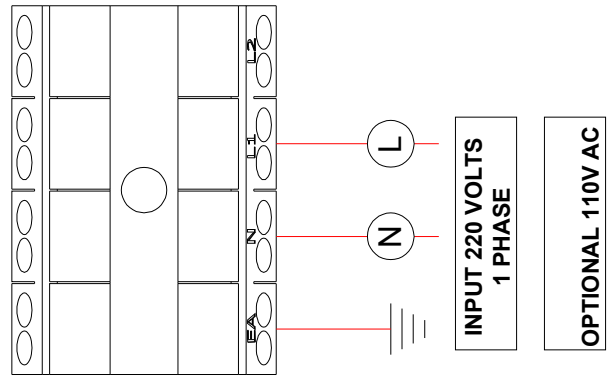

Figure 9B: Wiring Connections

- 1) Trigger Exit will unlock solenoid. The green arrow LED is shown.
 - 2) Trigger Entry will unlock solenoid. The green arrow LED is shown.
- (Triggers and commons require a voltage free normally open dry contact)

Live power (Live/Neutral/earth, 220V AC 50Hz, Optional 110V AC) needs to be connected as shown.

The triggers are similar and one trigger can be used for entry and exit. However, to use the EOT (end of transaction) outputs on the panel, triggers need to correspond to the direction of access.

The control board has a series of dipswitches for optional settings.

- 1) Multi-trigger - When ON, will store multiple triggers up to 3.
- 2) Fail-safe/secure mode - When OFF (Default) solenoid is fail-safe. This means when power fails, the gate will automatically unlock. When ON solenoid is fail-secure. This means when power fails, the gate will automatically lock. For this mode, the mechanism unit needs to be changed to a fail-secure unit, as it is supplied as default as a fail-safe mechanism (factory setting).
- 3-6) Delay - Setting these dipswitches on will provide the time delay for the gate to lock after closing. By default, this is all set to off. When putting multiple dipswitches on, the relocking time delay will increase, for instance setting 1 and 2 seconds on, will have a 3 second delay.

10. CHECKLIST

The following checklist needs to be adhered to during and after installation for commissioning of the unit.

Action	Requirement	Pass
Anchor Bolts Tightened	Check that bolts are tight and that cabinet is fixed securely	
Gate open and 'Hold-open'	With power off, open the gate to 90 degree (either left or right hand opening) and push slightly up to 90 degrees. The gate will hold in open position. Push the gate to less than 90 degree. The gate closes, slowing down when it reaches +-5 degrees.	
Locking check	With power on, trigger the gate, wait for the green arrow led and open. While holding the gate open, wait for the red cross led to switch on and release the gate. The gate closes, slowing down when it reaches +-5 degrees and locks.	
Cable check	All cables are correctly wired to the control panel. Power is connected and isolated. Cables are tied and running neatly in the channel upright, free from possible snagging and cutting.	

11. MAINTENANCE

The stainless steel should be cleaned once every two weeks as per the stainless steel maintenance manual.

Maintenance on the mechanism must be performed by a factory trained technician or an appointed representative. This unit is under guarantee and the guarantee will be considered void should unauthorized persons attempt repairs or maintenance.

12. PARTS & WARRANTY

Manufacturer guarantees the mechanical & electrical functions and parts for a period of 12 months after dispatch.

Parts for replacement purposes can be requested.

Note that the mechanism is only replaced as a whole unit, and the solenoid or cams will not be replaced separately.