

User Manual

MST150

Version: 1.0

Date: Dec. 2018

Table of Contents

- 1. Product Introduction 1
 - 1.1 Appearance and dimensions..... 1
 - 1.2 System component of the product..... 2
- 2. Features and specifications..... 4
 - 2.1 Features..... 4
 - 2.2 Specifications..... 4
- 3. Installation..... 6
 - 3.1 Installation environment..... 6
 - 3.2 Installation 7
- 4. Function Introduction.....10
 - 4.1 LED display10
 - 4.2 Operation10
 - 4.3 Detection Adjustment.....12
- 5. Troubleshooting13
- 6. Product Maintenance.....15
 - Chassis and base maintenance15
 - Movement maintenance15
 - Power maintenance15
- Warranty Card.....16
- Appendix Internal Wiring Diagram17

Notes

PLEASE READ THE FOLLOWING INSTRUCTION CAREFULLY BEFORE OPERATION:



1. It's available for indoor use, if need use outdoor, please use canopy to protect it against rain.
2. Choose the smooth and stable installation place, don't shake the device during security checking to avoid false alarm.
3. Make sure there's no big metal object or strong magnetic field around the device within 2 meters.
4. Device probe mustn't install in high temperature or wet circumstance.
5. Please wait 1 minute for its self-diagnosing when machine starts.
6. Do not disassemble the control cases except the professional technician.
7. Follow the user manual and make sure the right wire connection when the device starts.

1. Product Introduction

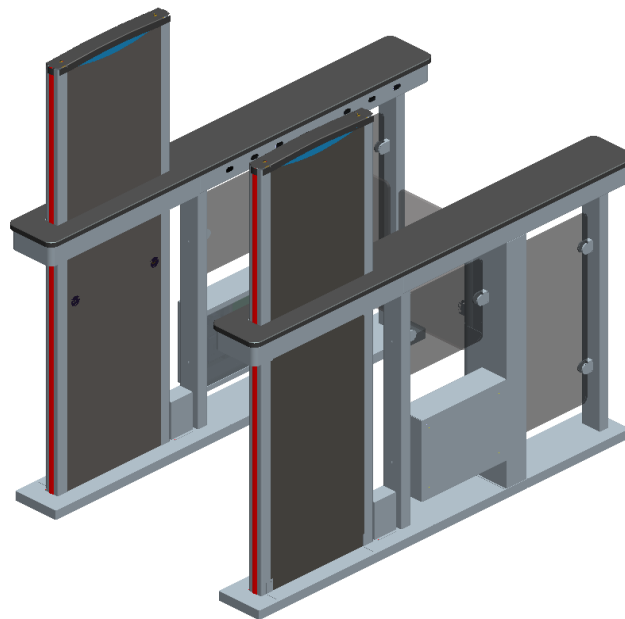

Integrated Metal Detector and Turnstile is mainly used to check the metal items hidden on the body. When the passengers pass through the device, if they don't carry metals, the indicator light turns green, the gate opens automatically, and the passengers can pass; if they carried metals more than preset parameters value, the device would alarm immediately, the indicator light turns red, the gate will not open, and the passengers can't pass. Free to pass when passing in the reverse direction.

1.1 Appearance and dimensions

MST150's appearance and dimensions are shown in Figure 1-1:

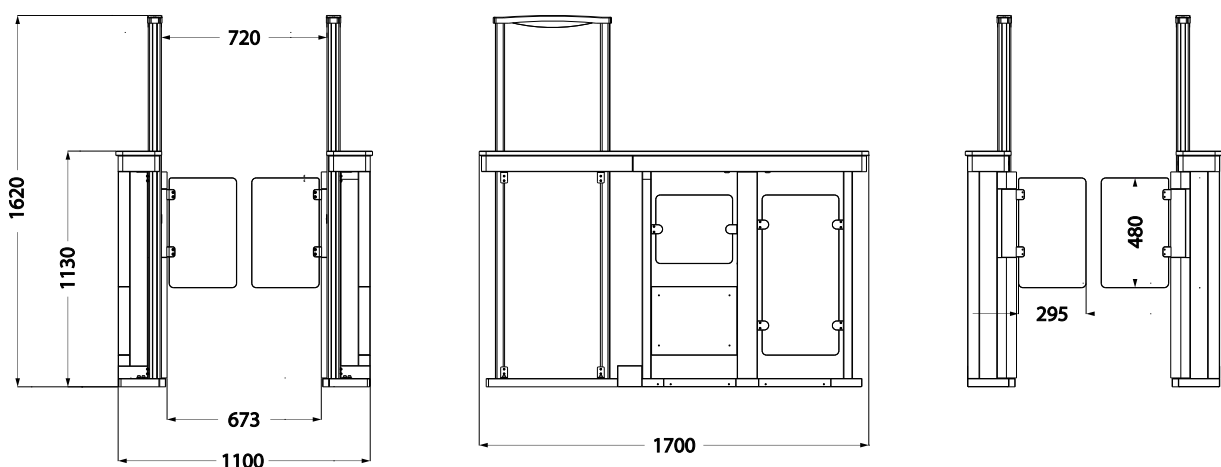
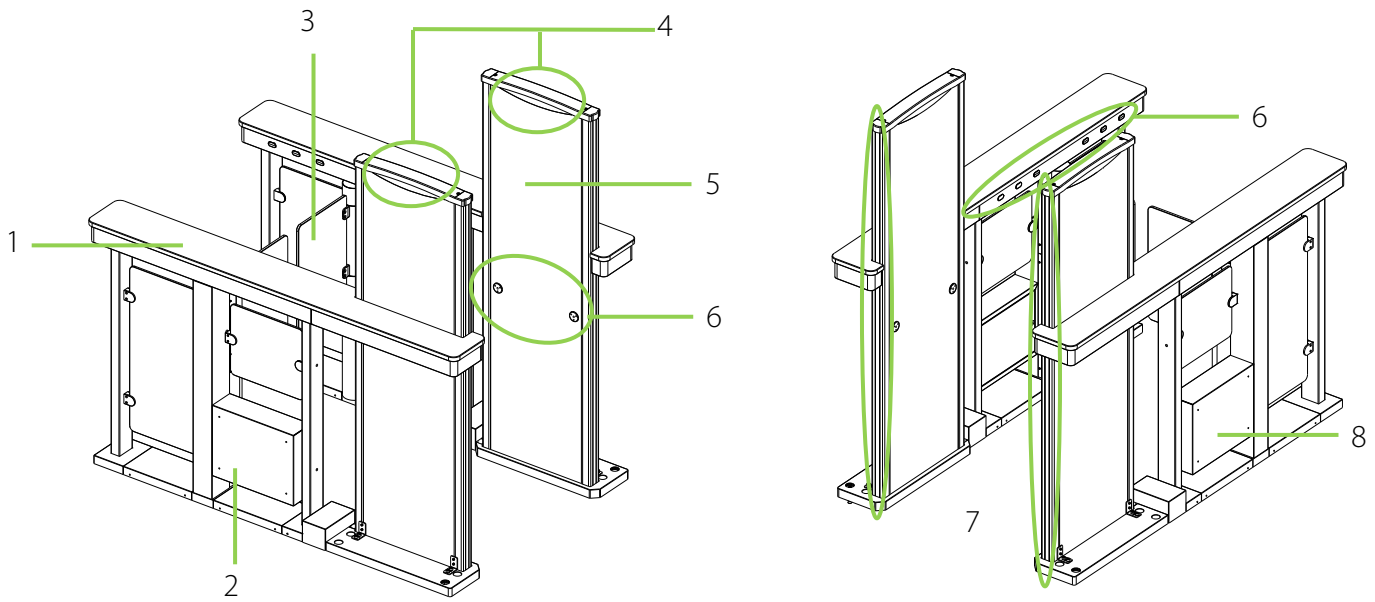

Figure 1-1

1.2 System component of the product



1. Swing Barrier

2. Swing Barrier Control Case

3. Barrier

4. LED Indicators

5. Metal Detector

6. Infrared Sensor

7. Alarm zone LED

8. Metal Detector Control Case

A. Alarm zones LED

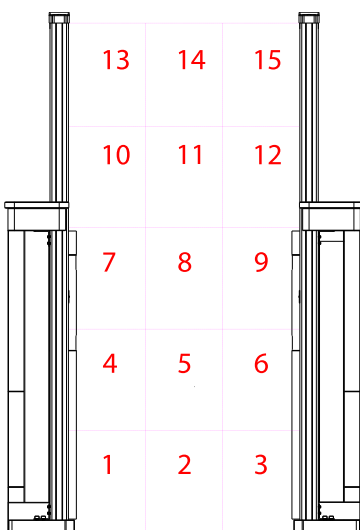

There are five unique sets of precise positioning LED evenly distribution on the door panels, each set is divided to 3 parts, means 15 detection zones (from bottom to top is zone 1, zone 2, zone 3, zone 4, zone 5...).

If the person carries metal, the LED on the corresponding zone turns red and alarms. If the metal is detected in the middle zones, the LEDs on both sides turn red.

B. Infrared sensor

After connected power supply, the device starts to work. When there is no person or object passes the device, the infrared sensors can effectively stop alarming to avoid false alarm. And accurate count passengers and alarm times.

2. Features and specifications

2.1 Features

- **Accurate Positioning:** 15 overlapping network detection zone, bilateral transmit and receive, can be accurately positioned to detect objects, intuitive display of the target location.
- **Micro Processor Technology:** the scanning electromagnetic wave generated by the microcomputer control circuit.
- **Sensitivity Adjustable:** each detection zone has 100 sensitivity levels (0 ~ 99). Preset metal size, you can exclude the coins, keys, jewellery, belt buckle etc.
- **Digital Pulse Technology:** digital signal processing and filtering system has excellent anti-interference ability.
- **Password Protection:** only the correct password can change the sensitivity and other parameters. Password with five digital, can be set by the user.
- **Count Statistics:** pass count and alarm count.
- **Harmless to human body:** harmless to heart pacemaker, pregnant women, magnetic floppy disk, recording tapes etc.
- **Reliability:** SUS304 stainless steel case ensures long-lasting durability.
- **Easy to install:** the system is integrated design, easy to complete the installation or disassemble.

2.2 Specifications

Detection Zone	15
Sensitivity	100 Levels
Channel	12
Work frequency	4KH-8KH
Alarm Relay	1-3 s
Open duration	0.8s (adjustable)
Speed of throughput	Maximum 30/ minute
Delay Close	0-5s
Infrared sensor	Swing Barrier: 6 pairs Metal Detector: 2 pairs

Lid material	Tempered Glass
Barrier movement	Swing
Power Supply Input Voltage	100 ~ 240V , 50/60Hz
Working temperature	-28°C ~ +50°C
Working Humidity	20%-95% (Non-condensing)
Working Environment	indoor
Weight	232KG (with package)
External Dimensions(mm)	1620(H)×1100 (D)×1700 (L)
Channel Dimensions(mm)	1620(H)×720 (D)×1700 (L)

3. Installation

3.1 Installation environment

Please read the following precautions carefully before installation to avoid affecting the use.

- 1) The floor should be flat and fixed, to avoid false alarm by the movement of people walking or moving and shaking of metal objects.
- 2) Keep away from the wall **more than 50cm**.
- 3) The device should not be used in corrosive environment.
- 4) Keep away from **the stationary or fixed bulk metal items** such as aluminum alloy, stainless steel doors and windows, with reinforced wall, etc. **more than 2 meters**.
- 5) Keep away from **the big movable metal items** such as rolling gate, iron security doors, elevators and cars **more than 5 meters**.
- 6) **Any electromagnetic interference sources and electromagnetic radiation source** is not allowed to close the device, the recommended distance is **more than 2 meters**.

The electromagnetic interference sources and electromagnetic radiation sources as following:
Electrical Control Box, Radio Equipment, Interphone, Electronic Computer And Peripheral Equipment, Video Monitor, High Power Motor, Power Transformer, Ac Power Lines, Thyristor Control Circuit (High Power Switching Power Supply, Inverter Welder), Engine, Motor etc.

- 7) Make sure **the protective ground wire** of the system is reliably connected to avoid personal injuries or other accidents.
- 8) After installation, check if the connection is done correctly at the connecting points of the protective ground wire, at the connector assemblies and wiring points of the circuits, as well as at each movable part of the device. Any loose nuts, screws and other fasteners should be tightened in time.
- 9) When installing the devices side by side, the distance between two cannot be less than **100cm**. Specific distance parameters according to the actual environment and the selection of the work frequency to adjust.

3.2 Installation

Step 1 Preparation

1. **Tools:** Measuring tape, adjustable wrench, impact drill and small screwdriver.
2. **Material:** Fireproof PVC and insulation tube (diameter $\geq 25\text{mm}$), standard three-core power extension wire, M12 expansion screw (included).
3. Pull/Run the wires through insulation tube before laying them underground.
4. Power wire and signal wire should be kept separately to avoid interference between strong and weak power. It is recommended that the wiring is to be done by a professional. And the device must be connected to the ground.

Step 2 Draw the mounting line

Draw parallel lines based on the center line of the device.

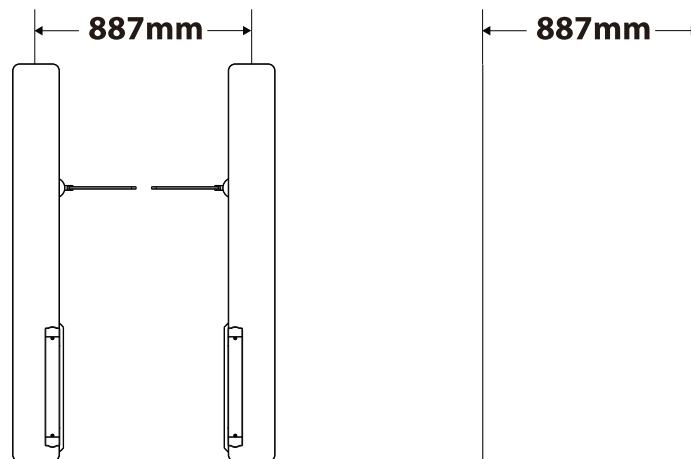

Step 3 Mark the mounting holes and drill

Mark the screw holes at the centre of the stand, and the edge of the chassis base on the ground according to the mounting paper.

Use a hammer drill to make M12 screw holes and then install the screws.

Step 4 Fix the device

Place the device according to the sizes and positions as shown in the figure before installation and fixing. Align the infrared sensor.

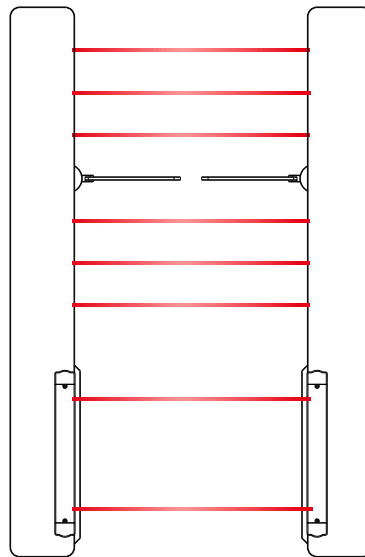

Step 5 Connect the cables

Connect the online cables.

The input voltage for the device is AC100-120V/200-240V and its master and slave are connected by a 5-core cable (signal) and a 2-core cable (power). When installing the device, the user only needs to connect it to the corresponding ports.

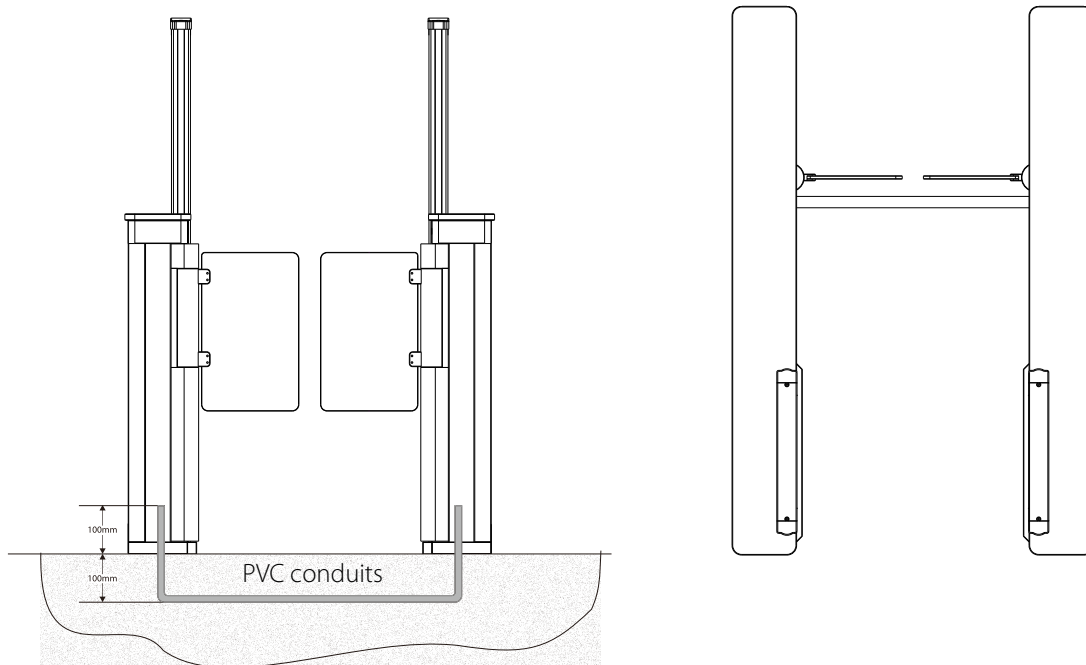

Note that the PVC conduits are laid 100mm under the ground, with the height of the exposed part not exceeding 100mm. In addition, the conduit outlet is bent back to prevent ingress of water into the conduit.

Step 6 Test

1. Wait for 1 minute for its self-diagnosing when machine starts..
2. Check if the indicator light works properly or not.
3. If the test is OK, tighten the screws.

It is recommended that a warning line be drawn for 50cm away from the device, so that the passengers can line up and pass one by one.

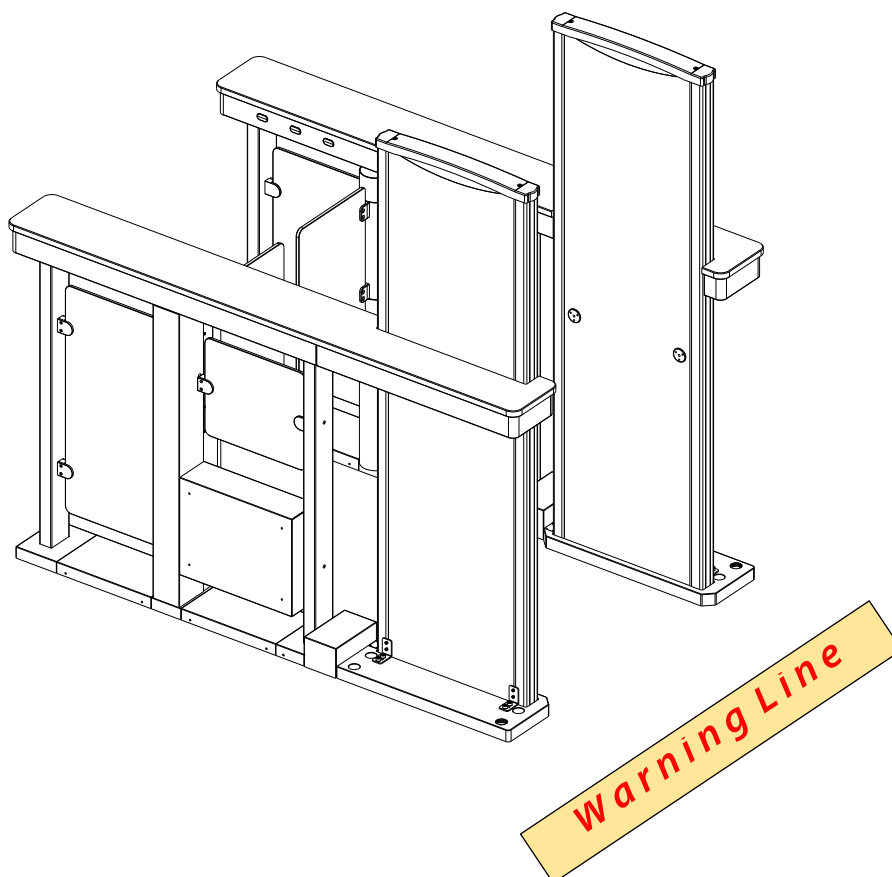

4. Function Introduction

4.1 LED display

LED display is in the metal detector control case. The sensitivity and frequency of the device must be set before use, and it cannot be modified during use.

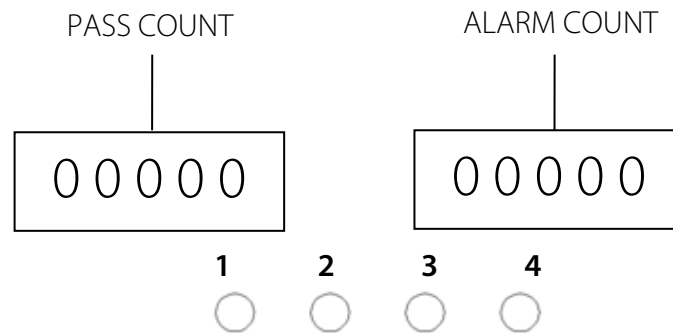

1. **ENTER:** confirm the data after adjusting, and change the single digit when setting the zone sensitivity level.
2. **SETUP:** Switch to various data, and change the tens digit when setting the zone sensitivity level. If press "SETUP" for 5 seconds, you can adjust the frequency. From frequency 1 to frequency 12 is optional.
3. **SELECT:** choose each program and increase the numerical value when input password.
4. **RESET:** reset PASS CNT and ALARM CNT. After adjusted the zone sensitivity, press RESET to confirm directly.

4.2 Operation

- **Power on/off**

Press and hold the reset button for 5 seconds to power on/off the metal detector.

- **Adjust the sensitivity and alarm time**

1. Press "SELECT", panel displays "12345". This is the initial password, if you have changed the password, please enter a password.
2. Then press "ENTER", if it shows "00000" (If displayed "00000", it means input the correct password, you can enter the next debugging program; if shown "E0000", means input the wrong password, need to input the correct password again).

3. Once again press "ENTER", it displays "d-01", (meaning: the alarm time is 1 second. 1-3 seconds for option).
4. Press "SELECT", it shows "1- XX" ("1" on behalf of the zone I, "XX" means the sensitivity value). You can press "SETUP" to change the tens digit and press "ENTER" to change the single digit. XX numerical is bigger, the sensitivity is higher.
5. In order press "SELECT", you can enter the next debugging program. It's for zone 2- zone 6. Zone 6 is overall sensitivity.
6. After adjusted the sensitivity, press "SELECT", it displays "d-01". You can press "SETUP" to change the alarm time. Default is one second.
7. After adjusted alarm time, press "ENTER". Then all the debugging programs have been completed. The device can work normally.
8. The device can automatically count the number of passengers and alarm times. Memory is 09999, press "RESET" to recount.

● **Adjust the sensitivity**

1. Press and hold "SETUP", it shows "F - XX" ("XX" means the frequency value).
2. Press "SETUP" to adjust the sensitivity. There are 1-12 frequencies to choose.
3. Press "ENTER" and then press "RESET".

● **Password input**

1. Press "SELECT", panel displays "12345".
2. Press "SETUP", panel displays "1-345". "-" is for adjustable digit. Continue press "SETUP" to shift "-".
3. Press "SELECT" can increase the number of "-".
4. After input the correct password, press "ENTER", it shows "00000". If shown "E0000", means input the wrong password; need to input the correct password again.
5. Press "ENTER" again, it displays "d-01". Then press "SELECT" to enter the next step.

● **Change password**

1. Press "SELECT", panel displays "12345". if you have changed the password, please enter a password.
2. If you have forgot the password, you can press "SETUP" and "SELECT" to change "E0000" into "88888", then press "ENTER". Panel displays "00000", press "SELECT" to input the number, then press "SETUP" to shift the digit.

3. After input the password you set, press "ENTER", displays "d-01", press "ENTER" again, the password change is completed.

4.3 Detection Adjustment

1. The device must be in a stable status to achieve the best detection effect (refer to the "Installation Environment"), to check whether the device in a stable status, the steps as follows:
 - a. The device is not shaking after power ON for 1 minute.
 - b. The device would not alarm when the tester did not carry any metal items walk through it.
2. Excluding small portable metal objects such as rings, key, belt buckle, shoes and so on, according to the following steps to adjust:
 - a. Choose a small metal as the sample, such as keys.
 - b. Increasing the sensitivity, so that when the tester carry the sample and pass through the device, it would alarms.
 - c. Decreasing the sensitivity a little, carry the sample pass through the device again, if it still alarms, once again to reduce the sensitivity, until the device not alarm when the sample passed through.

Note: If you want to decrease the sensitivity in a certain zone, only have to adjust the sensitivity of relative zone. After finished the above adjustment, the metal which smaller than the sample will not alarm, but the metal objects bigger than the sample can be detected accurately.

If need decrease total sensitivity, you can adjust zone 6.

3. Traffic regulations:
 - a. Draw a waiting line for 50cm away from the device, so that the passengers can line up and pass one by one.
 - b. Before the passengers walk through the device, they should remove all the carried metal objects (such as keys, mobile phone, watch, coins, etc.), place on the side of security chute or a table, and pick it up after security checking.
 - c. Passengers should line up one by one to pass the device, do not crowd, walk through with normal speed, cannot intentionally rush or postponed, and do not crash the door panel.
 - d. If the devices alarms when someone passes through, that means there are some metal objects were hidden in his body. The security guard can use a hand-held metal detector accurately detect the hidden position according to the alarm zones.

5. Troubleshooting

Number	Failure description	Analysis and solution
1	No response from direction indicator or indication is not correct.	Check whether the connection of the roof lamp is correct or not.
2	Delay in barrier opening doesn't close.	Check whether the time of the opening is too long or the IR sensor is covered.
3	Motor doesn't rotate, the resistance is much, or the belt is loose.	The motor works properly, but the rotated angle is not sufficient, so it may cause loosening of belt.
4	When powered ON, the swing doesn't return to the initial position.	Ensure that no obstacle is in the sensing area, then restart the equipment.
5	Infrared sensor cannot count.	<ul style="list-style-type: none"> a. Check the probe cables were well connected with the door panels. b. Check whether there are some infrared interference beside the device, such as: infrared surveillance system, infrared remote control (when press button), outdoor sunlight, etc. c. If both a and b are OK, please replace the Infrared sensor.

6	False alarm.	<ul style="list-style-type: none">a. Firstly, check the installation environment. Make sure there is no movable or stationary large metal objects around in 1.5 meters. In addition, make sure the installation location no wind cause shaking.b. If the false alarm not caused by the environment, please reduce the sensitivity of all zones.c. Change the frequency.d. Change the installation location.
---	--------------	------------------------------------------------------------------------------------------------------------------------------------------------------------------------------------------------------------------------------------------------------------------------------------------------------------------------------------------------------------------------------------------------------------------------------------------------------

6. Product Maintenance

Chassis and base maintenance

Most of the chassis and base of the device are made up of SUS304 stainless steel. If it is in service for a longer period, then there may be rust stains on its surface, regularly sand the surface along the grain softly and carefully. Coat the surface with anti-rust oil; do not cover the infrared sensor.

Note: The base of metal detector is made of wood and painted on the surface. Please pay attention to corrosion and scratching.

Movement maintenance

Switch off the power supply before maintenance. Open the door, clean surface dust, and lubricate the transmission mechanism. Check the belt movement, if found loose, adjust the position of the motor to tighten the belt. Check and tighten others connection parts.

Power maintenance

Switch off the power supply before maintenance. Check the plug connection, if found loose, fix it properly. Do not change any connection position randomly. Check the external power supply insulation periodically. Do periodic check for any kind of leakage. Check if the technical parameters of interface are normal. Check the service life of the electronic components and replace accordingly.

Caution: Above mentioned maintenance method for swing barrier must be carried out by professional personnel. Especially the movement and the electric control part, first switch off the power supply, ensure the operation safety.

Warranty Card

1. Please keep this card with reasonableness, and show it when maintaining it.
2. This card will be invalid if without the signature or stamp of the designated dealer.
3. This card will be regarded as invalid if it has not been filled in details three guarantees and acknowledgment of receipt. Please confirm whether the data filled in the three guarantees and acknowledgement of receipt is correct or not when purchasing it, and then hand it over to the dealer.
4. This card will not be supplied again if losing it.

Model Number	
ID	
Date Acquisition	
User	
Post Code	
Address	
User's Phone Number	
Fax	

Date of Maintenance	Record of Maintenance	Maintainer

Appendix Internal Wiring Diagram

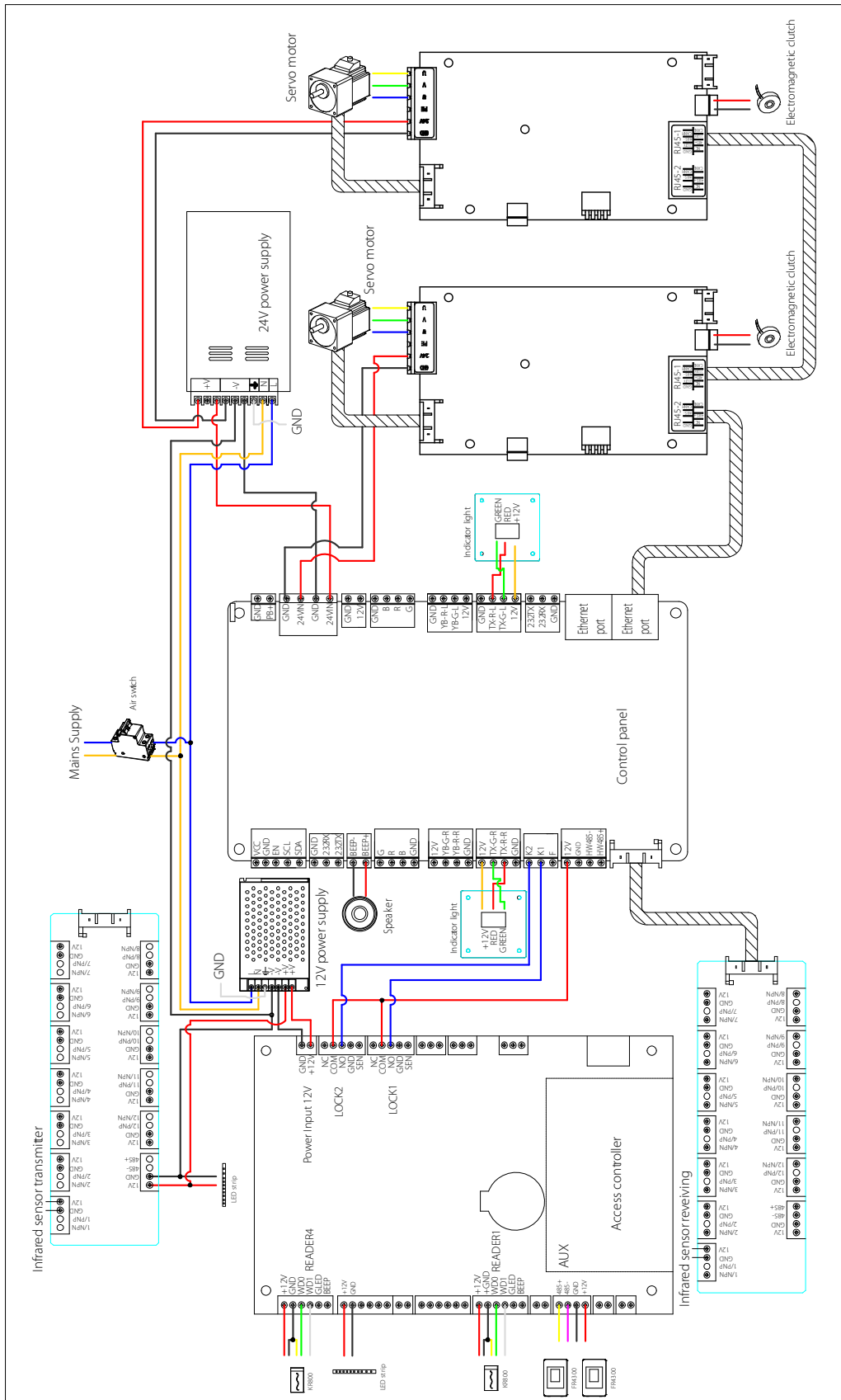



www.TURNSTILES.us

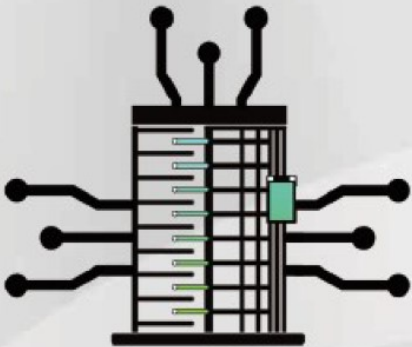

TURNSTILES.us

ZKTeco USA

