

# STOREFRONT SYSTEMS

## SERIES 400 & 450 CENTER GLAZE

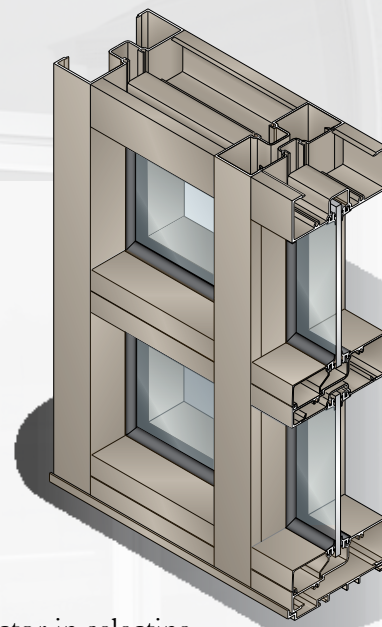

- Series 400 - 1-3/4" x 4" (44.5 x 101.6 mm)
- Series 450 - 1-3/4" x 4-1/2" (44.5 x 114.3 mm)
- 1/4" or 3/8" (6 or 10 mm) Glazing Infills
- Injection Molded Water Deflectors
- Screw Spline Assembly
- Shear Block Assembly
- Stacking Installation Option
- Full Range of Accessory Components
- Available in Anodized or Painted Finishes
- Interior or Exterior Glazed



Fabrication and installation labor costs have always been a decisive factor in selecting framing systems for storefront projects. We offer cost efficient versatile Center Glazed Systems with clean lines and superb performance. All series may be interior or exterior glazed. A top load E.P.D.M. gasket is used to position and weatherseal the glass in the aluminum pocket. Center Glazed Systems are compatible with most Storefront Entrance Doors.

## SERIES 400 & 450 STOREFRONTS TYPICAL DETAILS

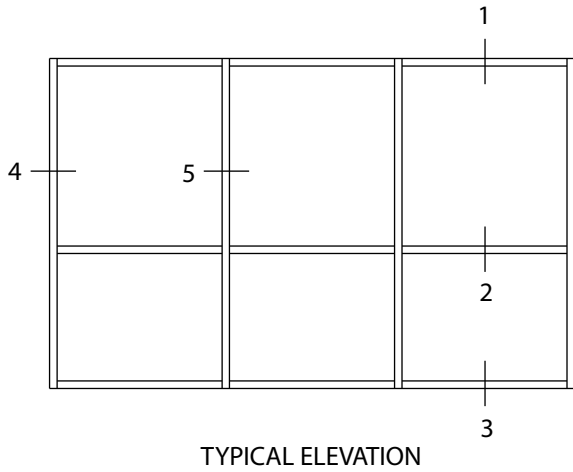

Series 450 details shown; Series 400 are similar.  
Our Center Glazed Systems can be interior or exterior glazed, with Screw Spline or Shear Block Assembly.

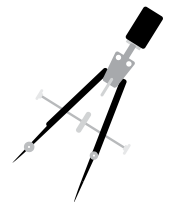
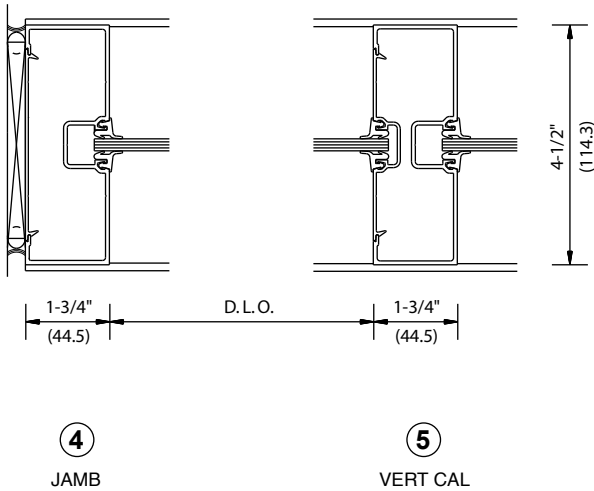
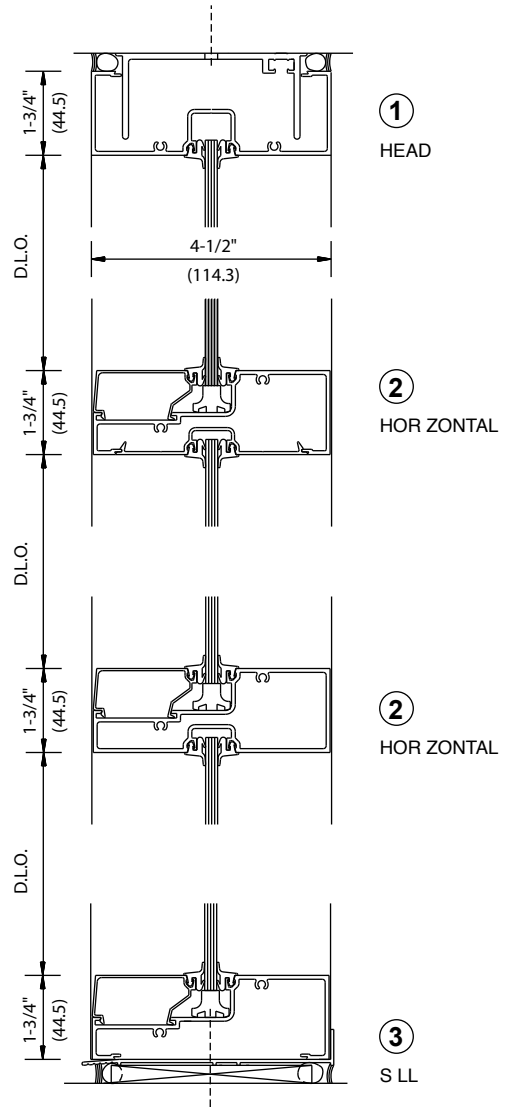

NOT TO SCALE