

TRITON

FULL HEIGHT CURVED GLASS TURNSTILE

**- 10 YEAR -
GUARANTEE**

INDUSTRY LEADER

- The TRITON FULL HEIGHT is designed to be a high security and aesthetic access control solution
- Exported worldwide



APPLICATIONS

- Suited for applications requiring high volume access and high levels of security
- Used extensively in applications such as office reception areas, commercial buildings and universities

DESIGNED FOR

- Interior installations
- Harsh operating conditions

AVAILABLE CONFIGURATIONS

- 1600mm diameter and 1500mm diameter
- 3 arm (120°)
- Single

SECURITY RATING

- 4/5

FEATURES OF THE TRITON FULL HEIGHT TURNSTILE

ROTALOK® ROTATION LOCKING MECHANISM

- Fitted to all Triton Full Height turnstiles
- Ultra heavy-duty electromechanical rotation locking mechanism
- Bi-directional operation
- Designed by professional engineers
- Tried, tested and perfected over a period of over 20 years

RELIABLE TECHNOLOGY

- Self-centering rotation system - rotor returns to starting position after every rotation
- Anti-Trap® safety system - no mid-rotation locking or trapping in the event of a power failure
- Extra secure 60° anti-reverse system
- Programmable PLC logic with user diagnostic features
- Mechanical key override - clockwise and anti-clockwise directions (fail-secure)

DURABLE FEATURES

- Zinc plated for corrosion resistance
- Ultra quiet, buffered solenoids and pawls
- Solenoids rated for 100% duty cycle
- Case hardened locking disk and pawls - eliminating any wear
- Factory settings need no further adjustment
- No routine maintenance whatsoever, ever

RELATED PRODUCTS

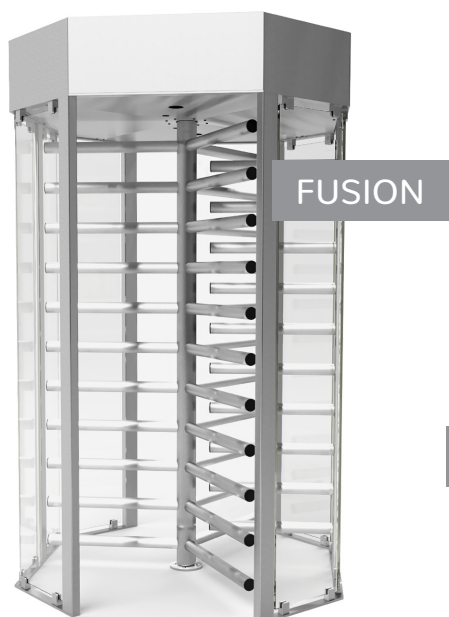

TECHNICAL SPECIFICATIONS

POWER	220 Volt AC (110 Volt AC on request)
FREQUENCY	50Hz / 60Hz
POWER CONSUMPTION	50W
SOLENOID VOLTAGE	24 Volt DC (12 Volt DC on request)
LOGIC VOLTAGE	24 Volt DC
DIAMETER	1600mm wide (factory standard) and 1500mm wide options
ROTOR WING CONFIGURATION	3 wing (120°)
FORM	Curved
ROTOR GLASS WINGS	8mm toughened glass
FRAME GLASS INFILL	6mm toughened glass
PUSH HANDLES	Stainless steel
LIGHTING	2 low-voltage downlighters
PRESSURE MAT	Combination of steel plates and foam covered by carpet indicating not entry
DESIGN	Modular bolt-together design for ease of transport and installation. Components can pass through a standard door. Can be packed in broken-down form either onto a pallet or into a crate for transport
SYSTEMS INTEGRATION	<ul style="list-style-type: none"> • Integrates with all access control and time and attendance systems • Unlocking for entry / exit rotation controlled through normally open dry contact • Transaction / rotation complete output • Integral wireways with draw wires in place - no exposed wires

MANUFACTURING OPTIONS

ROTATION OPTIONS	<ul style="list-style-type: none"> • Electrically controlled bi-directional rotation (factory standard) • Mechanically controlled uni-directional rotation by means of key override • Free rotation
LOCKING OPTIONS	<ul style="list-style-type: none"> • Fail-secure auto-lock on power failure (factory standard) • Fail-safe auto-unlock on power failure • Each direction of rotation configurable for either fail-secure or fail-safe operation
FIRE ALARM OPTIONS	Free rotation when triggered indefinitely (logic programmed for direction or rotation on request)
POWER OPTIONS	Battery backup with two 12 volt 7Ah batteries connected in series <ul style="list-style-type: none"> • Up to 1 000 transactions in fail-safe mode • Up to 60 minutes operation in fail-safe mode
ACCESSORY OPTIONS	<ul style="list-style-type: none"> • Card / proximity reader mounting brackets • Biometric / fingerprint reader mounting brackets • Single / double pushbutton in plastic housing • LED red cross and green arrow indicator light
PRESSURE MAT ACCESSORY OPTIONS	<ul style="list-style-type: none"> • Single pushbutton in plastic housing • Single button remote control and remote control transmitter and receiver
FRAME FINISH OPTIONS	<ul style="list-style-type: none"> • Mild steel with UV resistant polyester exterior powder coat finish (white) ■ • Mild steel with hot dip galvanised finish • 304 grade brushed stainless steel • 316 grade brushed stainless steel ▲ <p>▲ suitable for highly corrosive environments (details available on request) ■ other colours available on request</p>

TRITON CURVED RANGE

1600MM (FACTORY STANDARD)

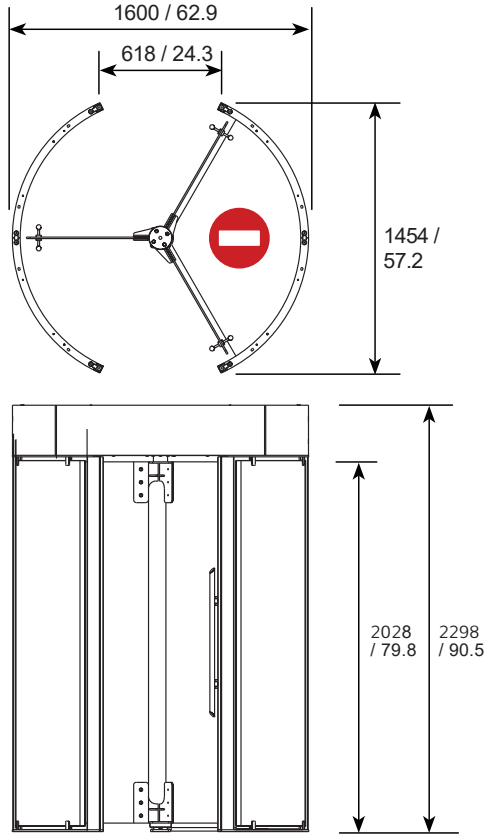

1500MM

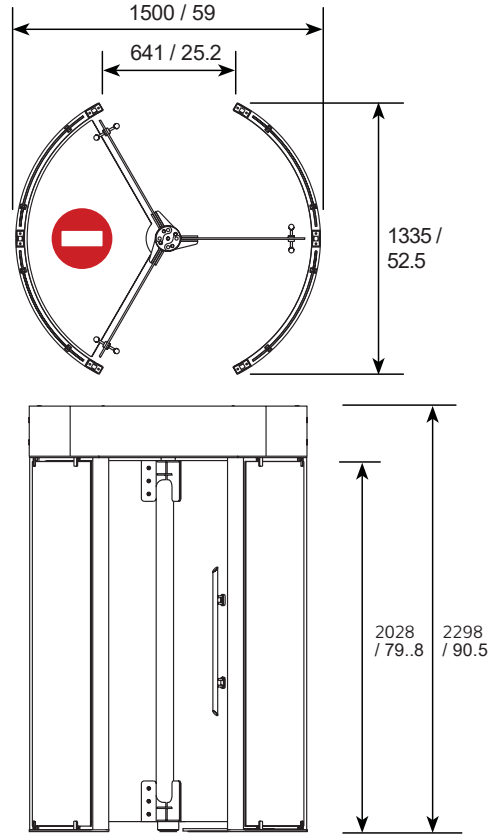

PRESSURE MAT OPERATION

STEP 1

ACCESS CONTROL READER IS TRIGGERED TO ALLOW AUTHORISED ACCESS IN THE DESIRED DIRECTION

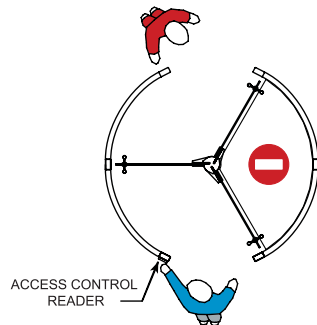

STEP 2

TURNSTILE UNLOCKS ALLOWING ROTATION IN THE AUTHORISED DIRECTION. AN UNAUTHORISED PEDESTRIAN MAY ENTER THE TURNSTILE AT THIS POINT

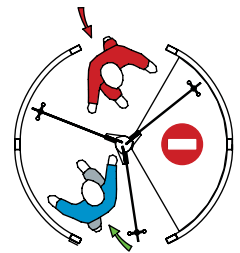

STEP 3

UNAUTHORISED PEDESTRIAN BECOMES TRAPPED INSIDE THE LOCKED TURNSTILE

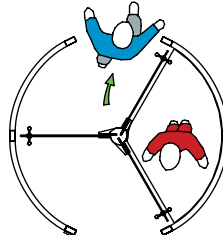

STEP 4

BUILDING SECURITY IS ALERTED AND A PUSHBUTTON /REMOTE CONTROL IS USED TO UNLOCK THE TURNSTILE AND ALLOW REVERSE ROTATION OUT OF THE TURNSTILE

