

User Manual

mTS1000 Series Tripod Turnstile

Date: December 2021

Doc Version: 1.0

English

Document Conventions

Conventions used in this manual are listed below:

GUI Conventions

For Software	
Convention	Description
Bold font	Used to identify software interface names e.g. OK, Confirm, Cancel.
>	Multi-level menus are separated by these brackets. For example, File > Create > Folder.
For Device	
Convention	Description
<>	Button or key names for devices. For example, press <OK>.
[]	Window names, menu items, data table, and field names are inside square brackets. For example, pop up the [New User] window.
/	Multi-level menus are separated by forwarding slashes. For example, [File/Create/Folder].

Symbols





Convention	Description
	This represents a note that needs to pay more attention to.
	The general information which helps in performing the operations faster.
	The information which is significant.
	Care taken to avoid danger or mistakes.
	The statement or event that warns of something or that serves as a cautionary example.

Table of Contents

- 1 OVERVIEW..... 4**
- 1.1 FEATURES..... 4
- 1.2 APPEARANCE AND SYSTEM COMPONENTS..... 5
 - 1.2.1 APPEARANCE..... 5
 - 1.2.2 SYSTEM COMPONENTS..... 5
- 1.3 MECHANICAL SYSTEM..... 6
- 1.4 ELECTRONIC CONTROL SYSTEM..... 6
- 1.5 WORKING PRINCIPLE..... 6
- 1.6 WORKING MODES OF THE SYSTEM..... 7
- 1.7 TECHNICAL SPECIFICATIONS..... 7
- 2 FUNCTION INTRODUCTION..... 8**
- 2.1 FINGERPRINT VERIFICATION..... 8
- 2.2 CARD VERIFICATION..... 9
- 2.3 QR CODE VERIFICATION..... 9
- 2.4 WIRED REMOTE CONTROL★..... 10
- 2.5 WIRELESS REMOTE CONTROL★..... 12
- 3 WIRING DIAGRAM..... 14**
- 4 PACKING LIST..... 15**

1 Overview

The mTS1000 Series is one kind of our innovative semi-automatic tripod turnstile series, it is made of SUS304 Stainless Steel, with the acrylic panel on the top, which is beautiful in appearance and clean and is anti-rust. The top cover panel of the mTS1000 Series integrated general access control is customizable according to different verification modes. The mTS1000 Series runs smoothly and quietly and consumes little power thanks to its small and compact body design.

The mTS1000 Series tripod arms are normally held in a locked position, it grants legal access to the authorized persons and restricts illegal access. When a valid Card/Fingerprint/QR code is detected, arms unlock and automatically rotate at a slight push. During emergencies and power outages the tripod arms completely collapse, the lock will release to allow fast evacuation and egress, thereby ensuring users FAST unencumbered exit to safety. When the power is on, the arm will automatically lift up to form a secure lane.



1.1 Features

Design: Compact body, the device run smoothly, silently and consumes little power.

Count Statistics: Support the count of the number of people Inbound and Outbound.

Verification Modes: Multiple authentication methods, convenient and secure.

Gate Function: Supports anti-passback and fire mode.

1.2 Appearance and System Components

1.2.1 Appearance

The appearance and dimensions of the mTS1000 Series are shown in the figure below:

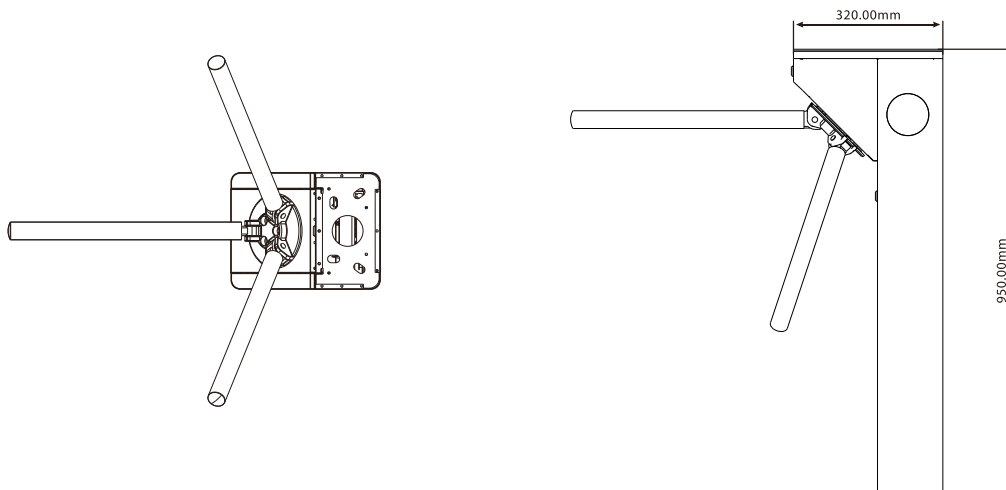

1.2.2 System Components

The system components of the mTS1000 Series are shown below:

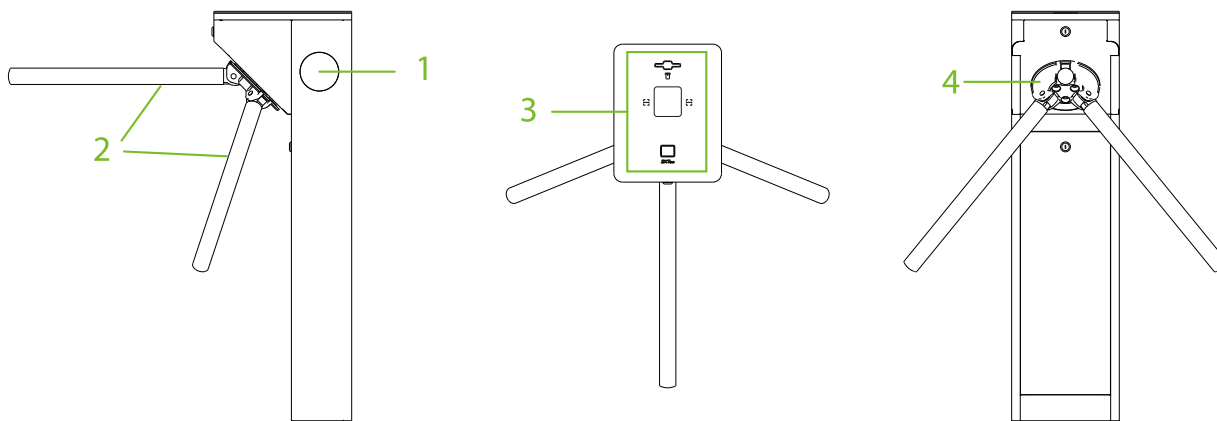

1. Direction Indicator	2. Arm
3. Verification Units	4. Disk Wheel

1.3 Mechanical System

The mechanical system of the tripod turnstile includes the chassis and the core component. The chassis is a carrier where the Direction indicator, Reader, QR code scanner, Fingerprint sensor and the Door lock are installed. The core component mainly consists of the Frame, Bearing, and Arm.

1.4 Electronic Control System

The electronic control system of a tripod turnstile is mainly composed of the Card Reader/Fingerprint sensor/QR code, Turnstile control board and Direction Indicator.

Reader: The reader reads the data in the card and sends it to the Access Controller.

Fingerprint sensor: The device compares the fingerprint that is being pressed onto the fingerprint sensor with all the fingerprint data and sends it to the Access Controller.

QR code sensor: The sensor compares the acquired QR code with all QR code data registered in the device and sends it to the Access Controller.

Turnstile control board: The turnstile control board is the system's control center that receives signals from the reader and the photoelectric switch performs logical calculation and processing of these signals and sends executive commands to the Direction indicator and arm.

Direction Indicator: This indicator displays the pedestrian passage path and directs them to pass through the lane in a safe and orderly manner.

1.5 Working Principle

1. After powering on to the device, the system performs the Power-On Self-Test.
2. When a valid Card/Fingerprint/QR code is detected, the buzzer will give a positive audible prompt to the pedestrian, indicating that successfully verified. And then, the reader sends signals to the Access Controller to request permission to pass through the passage. The Access Controller will send the signal to the master control panel.
3. After receiving the signal from the Access Controller, the turnstile control board sends valid control signals to the direction indicator and the arm. At last the direction arrow turns green.
4. Pedestrians according to the directional signs, gently push the unlocked arm, the arm will automatically rotate until the pedestrian through the channel.
5. If the pedestrian enters the passage but forgets to verify identification, or if the card held/fingerprint/QR code by the pedestrian is invalid, the system does not allow pass. The pedestrian can pass through the passage only after a valid card/fingerprint/QR code is successfully verified.

1.6 Working Modes of the System

To make the product more versatile, this system provides 2 working modes for the user, including Normally Open Mode and Normally Close Mode.

Normal Open Mode: In this working mode, the arm falls down.

Normal Close Mode: In this working mode, the arm is locked.

1.7 Technical Specifications

Feature	Specification
Communication	TCP/IP, RS485
Input Voltage	AC110V/220V, 50/60Hz
Input Control Signal	Switching Signal
Output Voltage	DC 24V
Protection Level	IPX3
Time of Gate Opening/Closing	Minimum 0.6 Second
Operating Humidity	< 93% (Non-condensing)
Operating Temperature	-20°C to 70°C
Flow Rate	Maximum 25/minute
Proximity Switch	Three pairs
Working Environment	Indoor/Outdoor (if sheltered)
MCBF	2 million
Working Power	40W
Standby Power	10W
Dimension (mm) (L*W*H)	798*750*950
Noise	< 60dB
Certifications	CE and FCC

2 Function Introduction

2.1 Fingerprint Verification

In this verification mode, the device compares the fingerprint that is being pressed onto the fingerprint reader with all the fingerprint data sends it to the Access Controller.

The device enters the fingerprint authentication mode when a user presses his/her finger onto the fingerprint scanner.

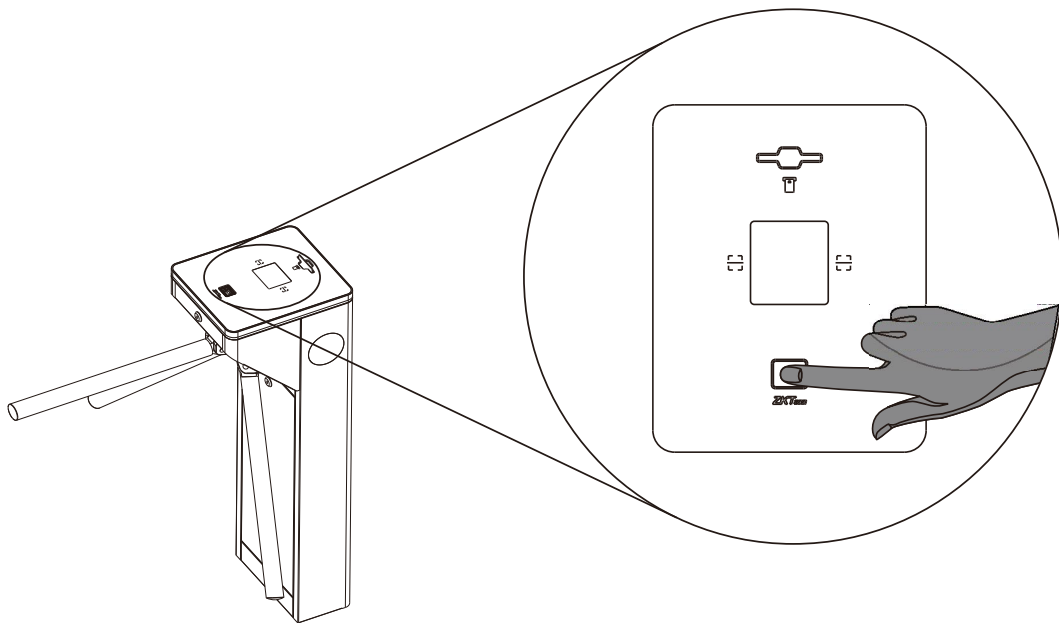

Recommended fingers: It is recommended to use index, middle, or ring finger for registration and avoid using the thumb or little finger, as they are difficult to accurately press onto the fingerprint reader.

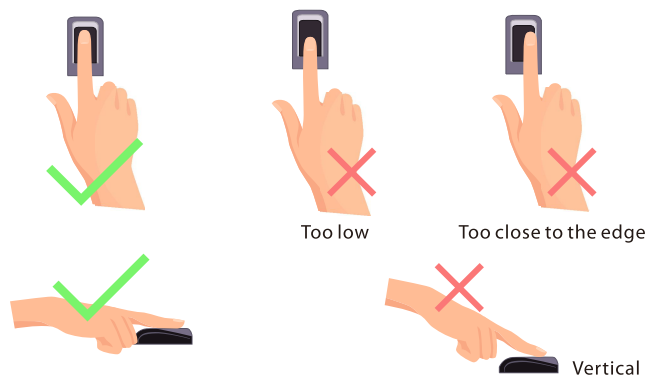

Note: Please use the correct method when pressing your fingers onto the fingerprint reader for registration and identification. Our company will assume no liability for recognition issues that may result from incorrect usage of the product. We reserve the right of final interpretation and modification concerning this point.

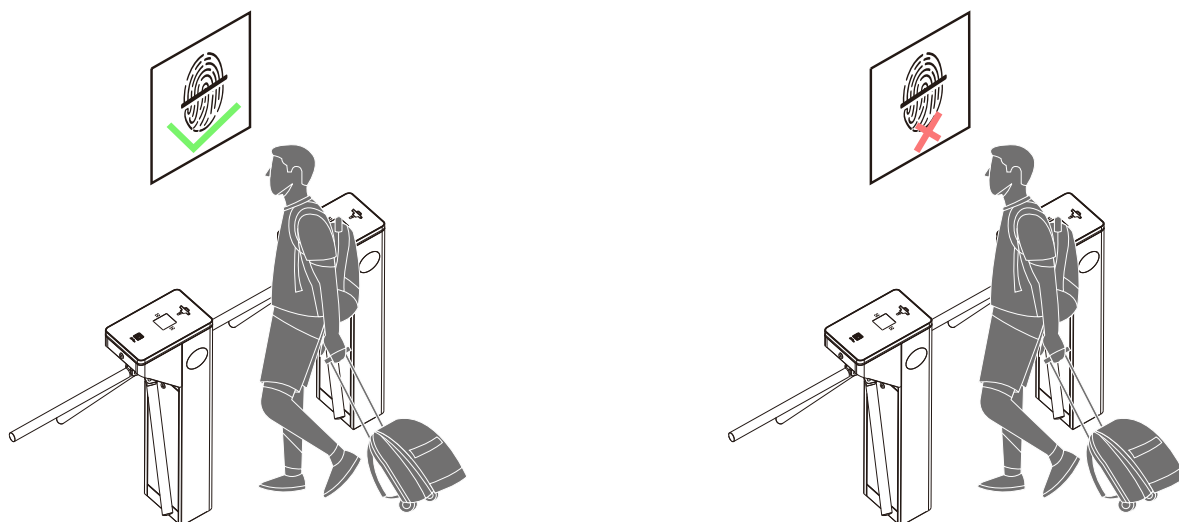

2.2 Card Verification

The Card Verification mode compares the card number in the card induction area with all the card number data registered in the device and sends it to the Access Controller.

The device enters the card authentication mode when a user presses his/her card to the card reading area.

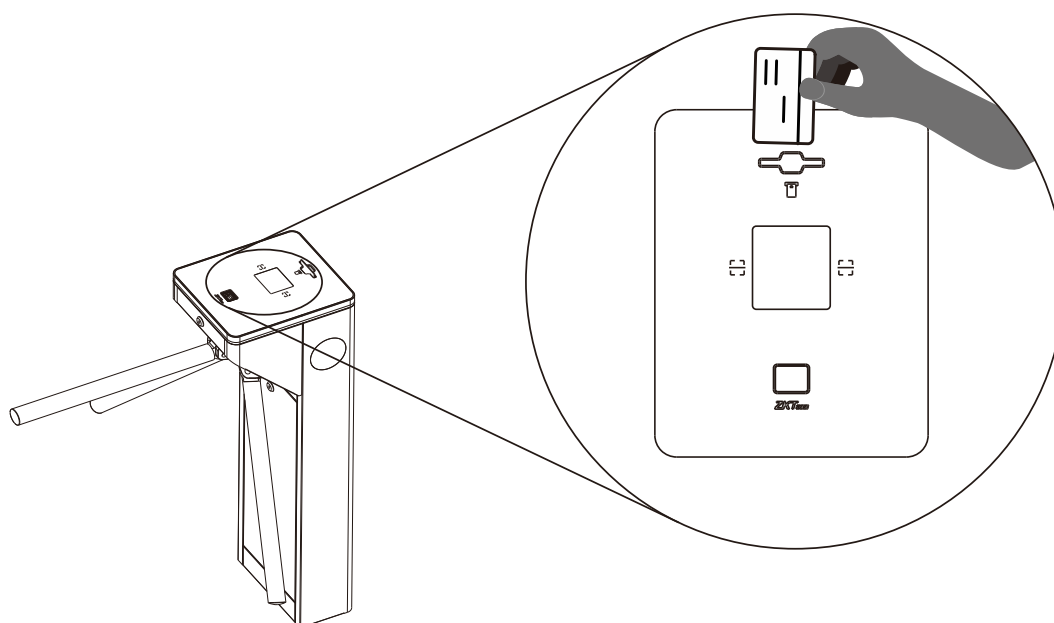

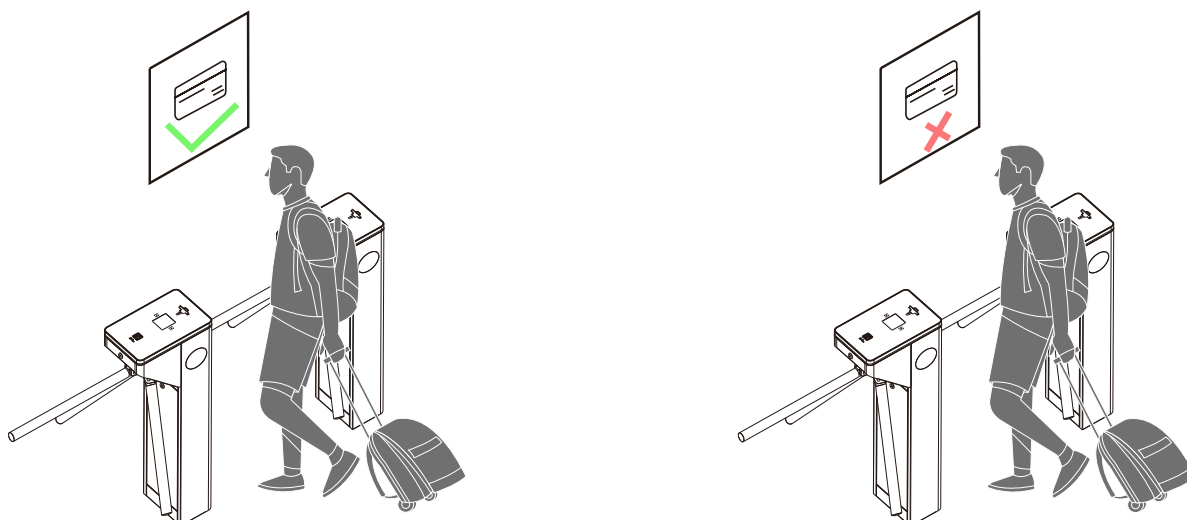

2.3 QR code Verification

The QR code Verification mode is to scan the QR code on the user's mobile phone through the QR code scanner and compare the data with the registered QR code, and then sends it to the Access Controller.

When the user places the mobile phone displaying with the QR code on top of the QR code scanner, the device enters the QR code authentication mode.

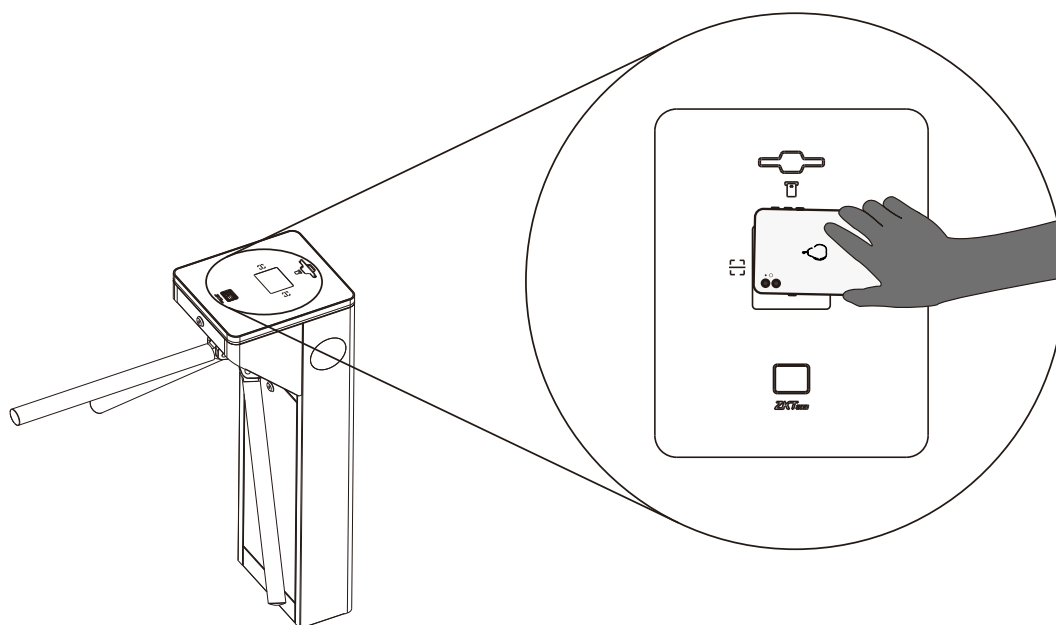

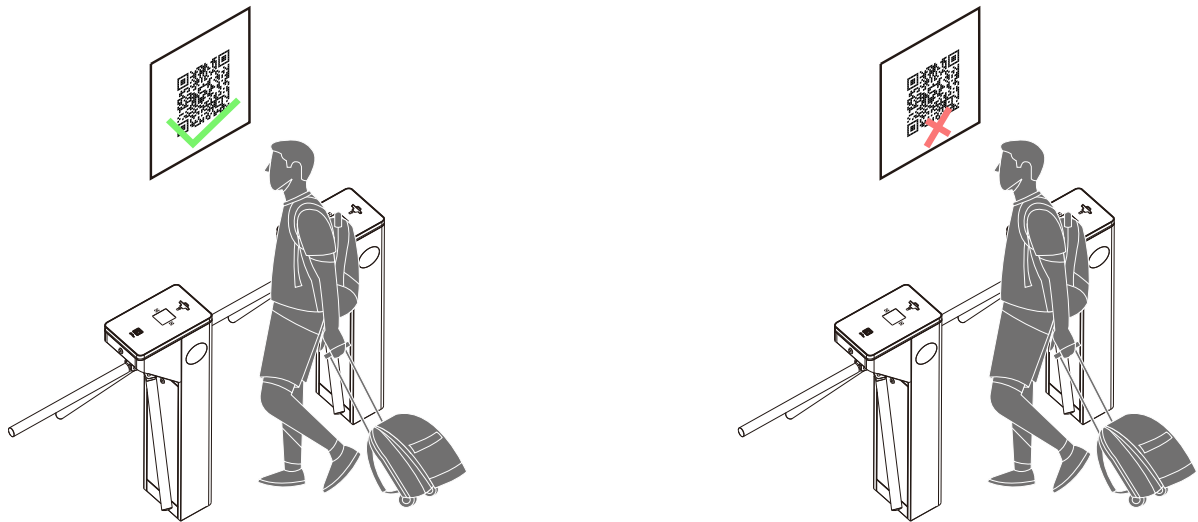



2.4 Wired Remote Control★

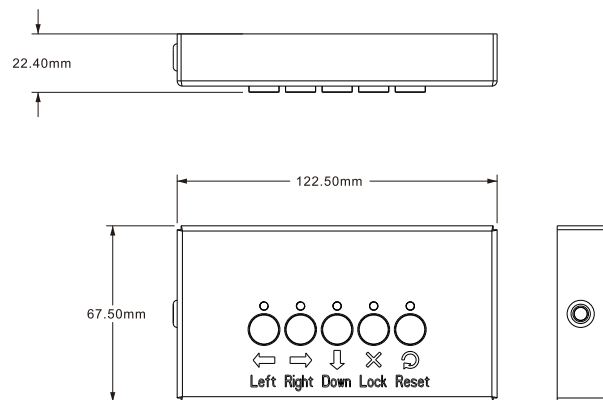

The wired remote control has five buttons, which are the Left button, Right button, Down button, Lock button, and Reset button. These five independent buttons have individual functions as well as combined functions. Pressing two buttons within the specified time interval can call up a predefined mode.















The following tables describe the modes of different button press actions:

1. Independent functions:

Buttons	Description
	Press the button once to open the tripod turnstile and can pass by identity verification from the inbound.
	Press the button once to open the tripod turnstile and can pass by identity verification from the outbound.
	In emergency mode, press the button once to fall the arm lever. Then the inbound and outbound sides get open and can pass freely without identity verification.

	Press the button once to raise the arm lever. Then the inbound and outbound sides are controlled by the tripod turnstile. The identity verification becomes invalid, and no pass is allowed.
	Press a button once to restore the default inbound and outbound identity verification pass mode of the arm.

2. Combined functions:

Status	Description
Inbound free, Outbound control	Press "  " twice to open the tripod turnstile on both sides. The inbound side is free to pass without identity verification and can pass by identity verification from the outbound.
Inbound control, Outbound free	Press "  " twice to open the tripod turnstile on both sides. The outbound side is free to pass without identity verification and can pass by identity verification from the inbound.
Inbound free, Outbound free	Press "  " and "  " at the same time to open the tripod turnstile on both sides and both inbound and outbound sides can pass freely without identity verification.
Inbound forbidden, Outbound free	First press "  " once, and then press "  " once, then the inbound side is forbidden to pass, and the outbound side is free to pass without identity verification.
Inbound free, Outbound forbidden	First press "  " once, and then press "  " once, then the outbound side is forbidden to pass, and the inbound side is free to pass without identity verification.
Inbound control, Outbound forbidden	First press "  " once, and then press "  " once, then the outbound side is forbidden to pass, and the inbound side needs to identity verification to pass.
Inbound forbidden, Outbound control	First press "  " once, and then press "  " once, then the inbound side is forbidden to pass, and the outbound side needs to identity verification to pass.

The wired remote control is connected to the controller, then set the controller's code pairing mode to complete the wired remote control's setup.

Dial code description:

The DIP switch is divided in eight dial codes from KE-1 to KE-8. Move the switch Up to turn ON and down to turn OFF.

Description of Function Setting:

- Dial 0 to turn OFF.
- Dial 1 to turn ON.

Dial code function item:

- **Unmanned passage time (KE-1, KE-2, KE-3):**

Switch Status	Time Period
000 (OFF OFF OFF)	5s (Default)
001 (OFF OFF ON)	10s
010 (OFF ON OFF)	15s
011 (OFF ON ON)	20s
100 (ON OFF OFF)	30s
101 (ON OFF ON)	40s
110 (ON OFF ON)	50s
111 (ON ON ON)	60s

- **Memory Swipe Mode (KE-6):**

Dial 1 (ON) to turn on.
Dial 0 (OFF) to turn off.

- **Turn on Alarm Mode (KE-8):**

Dial 1 (ON) to turn on.
Dial 0 (OFF) to turn off.

2.5 Wireless Remote Control★

The wireless remote control of the tripod turnstile is an intelligent device that remote controls the entrance and exit. It is designed for manual control of the tripod turnstile by the administrator. The wireless remote control has four buttons A, B, C, and D, corresponding to the options open entrance gate, open exit gate, emergency mode open-bar pass, and alarm lock.

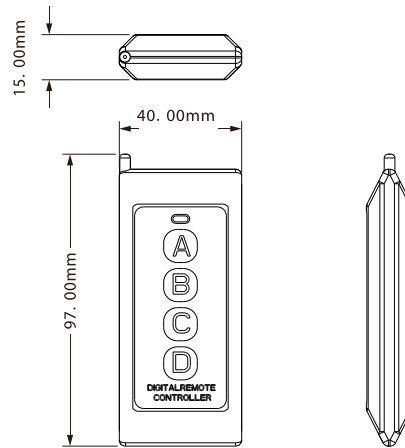

Buttons	Description
A	Press the button once to open the tripod turnstile on the inbound and can pass by identity verification from the inbound.
B	Press the button once to open the tripod turnstile on the outbound and can allow people to pass after their identity verification from the outbound.
C	In emergency mode, press the button once to fall the arm lever. Then the inbound and outbound sides get open and can pass freely without identity verification.
D	Press the button once to raise the arm lever. Then the inbound and outbound sides are controlled by the tripod turnstile. The identity verification becomes invalid, and no pass is allowed.

When the controller is powered on, the wireless remote control is not in communication with the controller. Press and hold the DIP switch of the controller to enter the code pairing mode and operate the remote control according to the eight DIP switch codes of the controller.

To code:

1. First, power the controller of the tripod turnstile.
2. Short press the learning button on the controller, and a light corresponding to the button will flash slowly. Then press any switch on the remote control for acquiring the information. After the successful operation, the light turns off.

Clear code:





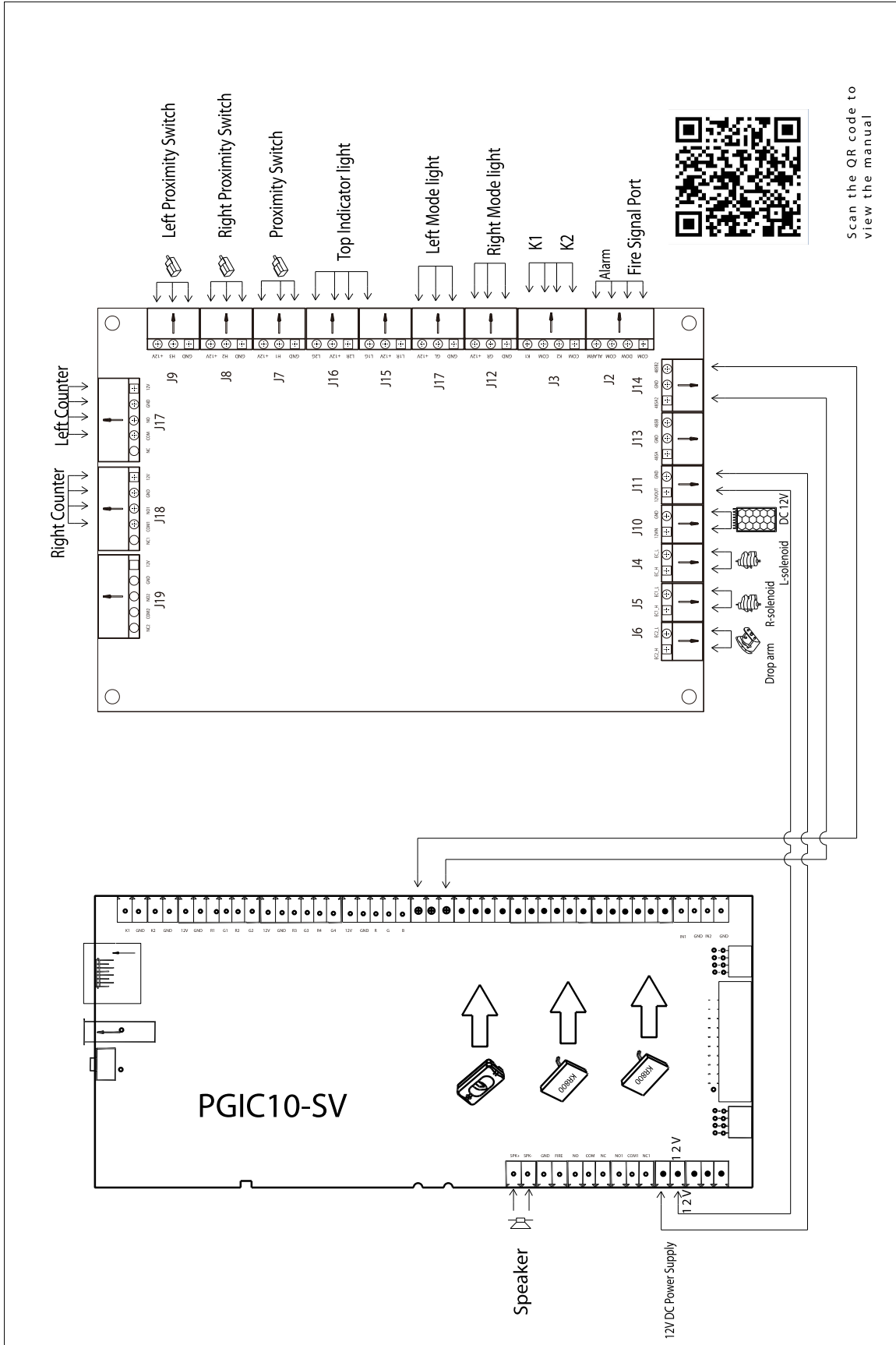

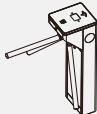

Long press the learning button on the three roller gate controller for 3 seconds. The learning light stays on for a while then turns off indicating the code is cleared successfully. The original learning remote control cannot be used again and can only be remote-controlled by the code again.

3 Wiring Diagram



4 Packing List

The package consists of the following items:

	mTS1000	1
	Power cable	1
	Card	1
	Expansion Screw M12*100	4
	Stainless Steel Maintenance Wipes	1
	Hex wrench	1
	Allen Screw	3
	Key	2
	Washer	3