



# CONTROL MODULE **MAGTRONIC** BA3 / GA / ZA2AL / BR2AL

## TABLE OF CONTENTS

CONTROLLER SOFTWARE	3
TECHNICAL DATA	3
GLOBAL FUNCTIONS	3
NAVIGATION	3
MAIN SCREEN	4
MAIN MENU	4
PARAMETERS MENU	4
MENU SETTINGS	4
PICTOGRAMS CONFIGURATION	5
LICENSE MENU	6
TEST MODE	6
DESCRIPTION OF THE CONTROL MODULE TERMINALS	6
MENU SETTINGS	8
ZERO POSITION	8
CALIBRATION	8
FIRST RUN	8
DEVICE CONNECTIONS	9

## CONTROLLER SOFTWARE

Device's control logic is controlled by the device manufacturer's software. The manufacturer grants licence to using the software only in cooperation with the purchased device and in order to control it. The abovementioned licence is granted by the

manufacturer for products purchased at the authorised distributors only. The licence is granted for:

1. The time of one month from the devices sales date (on the base of a trade credit).
2. An indefinite time - after the payment for the device has been made.

Changes or modifications to the software of whatever kind may be introduced by a detailed and written consent of the device manufacturer only. Making changes or modifications to the software without the manufacturer's consent are not covered by the licence regarding using the software. The manufacturer bears no responsibility for proper and safe operation of the device if changes of whatever kind have been made to the device's controlling software, without the device manufacturer's consent.

The manufacturer reserves the right to introduce changes or updates to the software. To obtain terms and manners of the software update, it is advised to contact our Sales Department. All devices are supplied with a stored standard software described in the manual herein. If a need to make changes of whatever kind to the device's software occurs, it is advised to contact the manufacturer's Sales Department. A software carrier is the device's control logic.

## TECHNICAL DATA

Supply power	24VDC / 24VAC
Storage humidity	10 - 90 %RH
Storage temperature	-40 - 85 °C
Operation humidity	10 - 90 %RH
Operation temperature	-20 - 70 °C
Power output load	max 120W
Fuse	5A

- Module's input signals- Short circuit to ground of an appropriate input pin with potential of 5V. Duration should be MIN: 0.2s, MAX: 1s.
- Module's output signals- Relay signals. Depending on which pair of pins is used, output signals can be normal opened or normal closed. Duration of the output signal can be configured in the driver's menu.



## GLOBAL FUNCTIONS





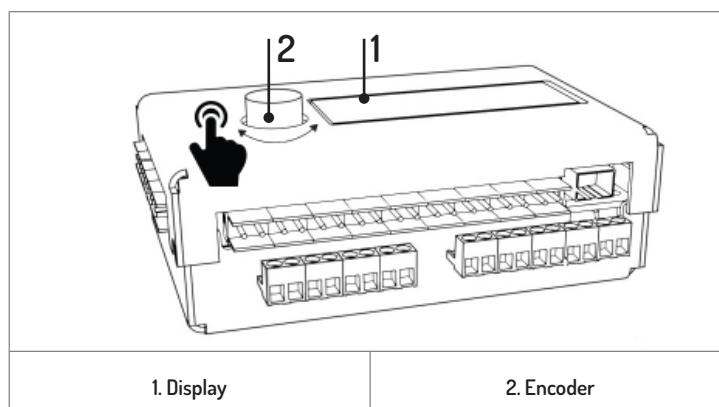

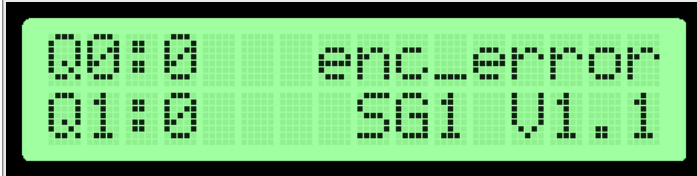
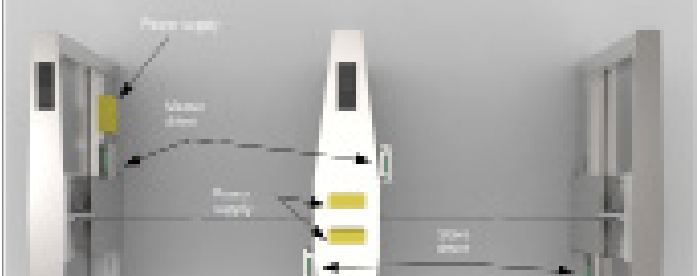
Global functions are functions that are common to all types of devices. Functions specific to a given device series are described in sections referring to a particular series of devices.

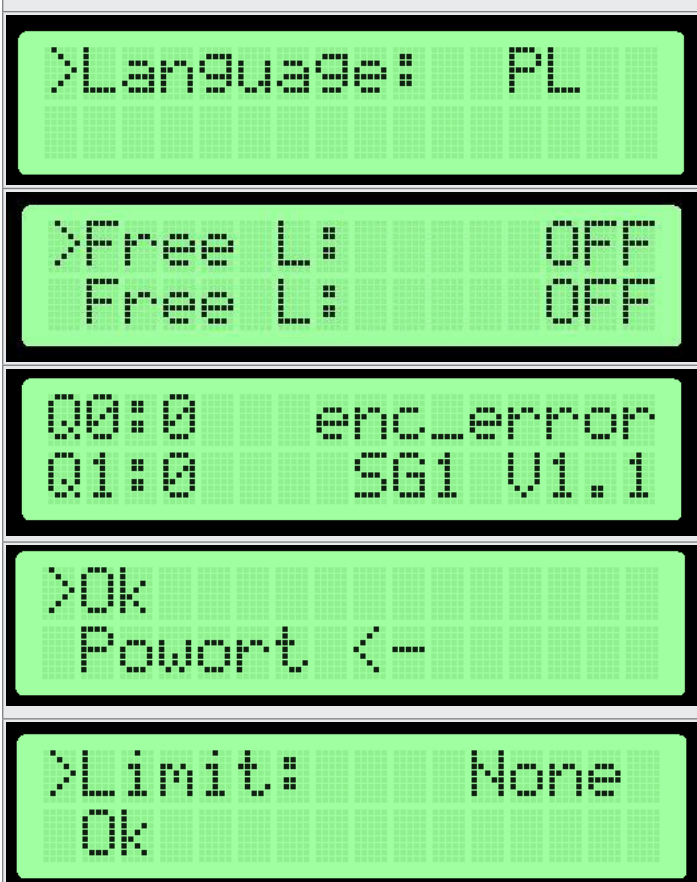
## NAVIGATION

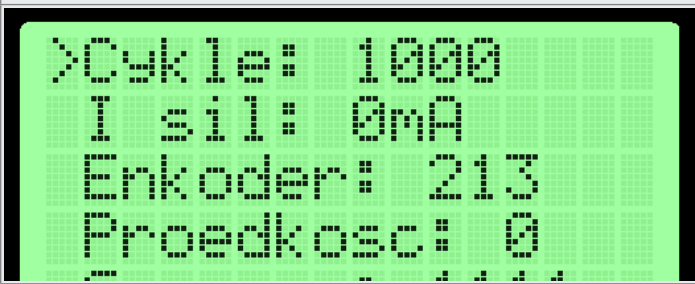
Use the rotary encoder to navigate through the menu. Turn it left or right to switch between menu positions. Press the encoder to enter the submenu or edit settings values.

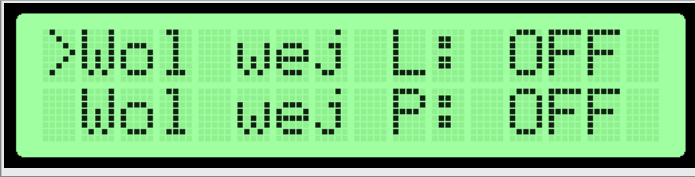

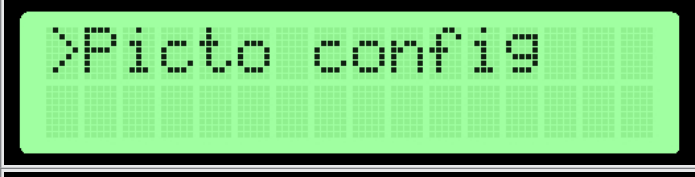
<p><b>MAIN SCREEN</b></p> 	<p>The main led screen is displayed when the power supply is on. On the left, the queue status is displayed (Q0 – queue for left direction, Q1 – queue for right direction). Errors are displayed in the upper right corner. Possible errors are:</p> <ul style="list-style-type: none"> <li>• Enc_error – encoder error, not connected or damaged</li> <li>• Lic_error – inactive license</li> <li>• Default_sett – memory read incorrectly – factory settings loaded</li> </ul> <p>In the bottom right corner the current version of software is displayed. Press the encoder to continue to the main menu.</p>
<p><b>MAIN MENU</b></p> 	<p>Currently chosen position is pointed by an arrow. Pressing the encoder confirms the choice.</p> <p>Main menu positions:</p> <ul style="list-style-type: none"> <li>• Parameters – current parameters preview</li> <li>• Settings – configuration of the device</li> <li>• Test mode</li> <li>• Back – return to the main screen</li> </ul>
<p><b>PARAMETERS MENU</b></p> 	<p>Items displayed in the parameters menu:</p> <ul style="list-style-type: none"> <li>• Cycles – quantity of cycles completed by the device</li> <li>• Motor I – motor measured current value</li> <li>• Enc – the position of the rotor encoder</li> <li>• Vel – current velocity of the rotor</li> <li>• Back – return to the main menu</li> </ul>
<p><b>SETTINGS MENU</b></p> 	<p><b>Language configuration</b> Choose the interface language.</p> <p>Default setting: PL</p> <p><b>Free entrance function</b> Set the free entrance in desired direction. Possible settings:</p> <ul style="list-style-type: none"> <li>• OFF – free entrance off. Passage possible only after receiving an external signal.</li> <li>• ON – free entrance on. Device is unlocked in the desired direction</li> </ul> <p>Default setting: OFF</p> <p><b>Queue size</b> Queue length is the maximum number of release signals sent at short intervals that can be stored in the device's memory. Values to choose from: 1-99</p> <p>Default setting: 3</p> <p><b>Opening time</b> The time is counted from the moment of receiving the release signal. After the expiration of the time the passage is blocked again. Possible values to choose from: 3-60 seconds.</p> <p>Default settings: 6s</p> <p><b>Input signals configuration</b> In. 1-4 setting defines the function of IN 1-2 and IN 3-4 inputs. Possible configurations:</p> <ul style="list-style-type: none"> <li>• open – short circuit results in releasing the rotor blockade</li> <li>• free – short circuit triggers the free entrance function</li> <li>• lock – short circuit results in blocking the external signals</li> </ul> <p>Default setting: open</p>

SETTINGS MENU	
	<b>Feedback signal type</b> This setting defines the type of feedback signal emitted by the device. Possible configurations: <ul style="list-style-type: none"> <li>• OPN/REC - a feedback signal is sent immediately after the passage is unlocked</li> <li>• CLS/END - a feedback signal is sent after the passage is locked</li> <li>• PAS - a feedback signal is sent after a correct passage detection in a given direction</li> <li>• STR - a feedback signal is sent after initiating the rotor's movement</li> </ul>
	<b>Feedback signal duration</b> Values to choose from: 0,5 - 1,5 s.  Default setting: 0.8s
	<b>Position zero</b> Selecting the Zero config option triggers the position zero configuration mode. This mode, along with the calibration mode is described in the sections below.
	<b>Calibration</b> Calibration submenu allows to set the engine movement necessary parameters. They are described in the following points.  This option is not available in gates of the following series: GA, BASIC
	<b>License</b> This menu allows you to insert the license key to unlock the license. Submitting an incorrect key results in a temporary blockade of this menu item.
	<b>Pictograms configuration</b> Pictograms configuration submenu allows to configure information pictograms. It is described in the following points.
	<b>Saving of the configuration</b> <ul style="list-style-type: none"> <li>• Save &amp; Exit - saves the changed settings and returns to the main menu</li> <li>• Cancel - discards the changed settings and returns to the main menu</li> </ul>
PICTOGRAMS CONFIGURATION	
	When you enter the pictograms configuration menu, you can choose two options: <ul style="list-style-type: none"> <li>• Standard - standard pictograms</li> <li>• RGB - gives a possibility to choose from amongst 16 pictogram option signaling an open passage (for the left and right side separately) and from amongst 4 pictogram options signaling a closed passage (for the left and right side)</li> </ul>

LICENSE MENU	
	<p>After choosing the License menu, the license number is shown on the screen. Use the encoder to enter a pin number. Rotate the encoder to change the number, and press to move the cursor to the next position. After entering the last digit, press the encoder to be able to navigate through the menu again.</p>
	<p>If the submitted pin is correct, after choosing OK option the license settings menu will be displayed. Choose the Back option to return to the settings menu.</p>
	<p>In the license settings menu you can define a limit of cycles. When the limit of cycles is reached, the device will not react to external signals and test mode, and the relevant information will be displayed on the screen. Possible values to choose from:</p> <ul style="list-style-type: none"> <li>• None - no limit</li> <li>• 1k, 10k, 50k 100k and 200k - limit in thousands</li> </ul>
	<p>In the test mode the device is working independently. It performs 5 cycles alternately in both directions. During the test, all the mechanisms connected to the controller are being used. Work parameters are shown on the screen. To cancel the test mode choose Back option.</p> <p>In devices of the BA3, BR2 and GA series the mode is used only in devices equipped in the rotor's movement support system.</p>

## CAUTION!



While starting the test mode no person can be found within the device moving elements range.

## DEVICES BA3/BR2/GA/ZA

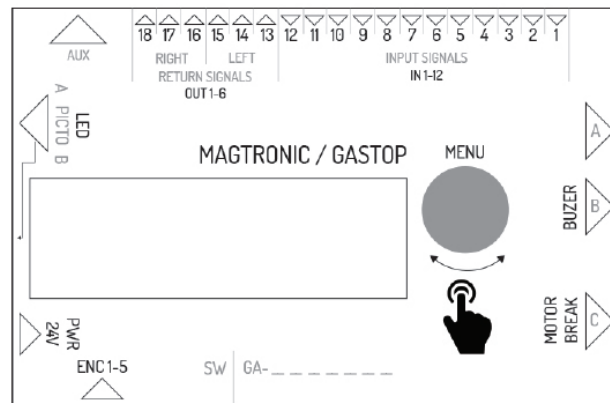
### DESCRIPTION OF THE CONTROL MODULE TERMINALS

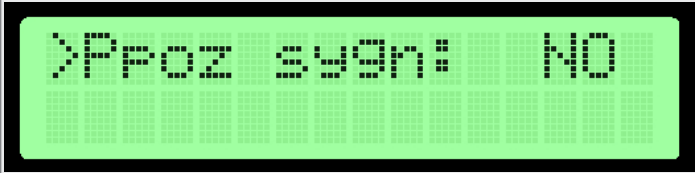
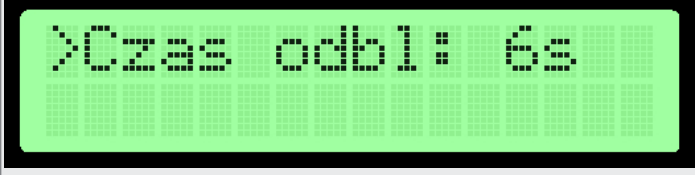
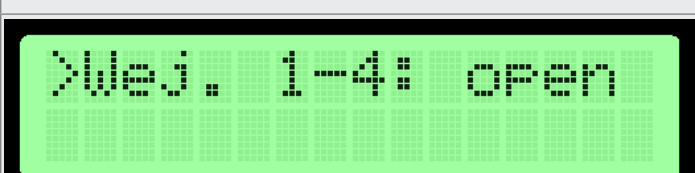

Symbol	Description
IN 1-2	External signal input for left direction (NO). This input's function is configurable. By default it's configured as permission to pass (see the software documentation).
IN 3-4	External signal input for right direction (NO). This input's function is configurable. By default it's configured as permission to pass (see the software documentation).
IN 5-6	Permission signal input for left passage direction (NO).
IN 7-8	Permission signal input for right passage direction (NO).
IN 9-10	Fire alarm signal input. The signal can be configured NO or NC in the driver's settings. After receiving a fire alarm signal the device turns on free passage mode for both passage directions
IN 11-12	Blockade signal input. Short circuit triggers the blockade – the device doesn't react to release signals.
OUT 1-3	Feedback signal output for left direction. The output consists of 3 pins that offer NO and NC signal. Duration of the signal and moment of it's occurrence can be configured in the driver's settings
OUT 4-6	Feedback signal output for right direction. The output consists of 3 pins that offer NO and NC signal. Duration of the signal and moment of it's occurrence can be configured in the driver's settings
AUX	Output destined for extension modules use
LED	Light signals output (diode pictograms)
PWR	Power connector- 24VAC
FUSE	Fuse- 5A slow type
ENC	Rotor's position encoder (5 pins)
BREAK	Electromagnetic brake control voltage output
MOTOR	Engine control voltage output
COIL_L	Left direction coil control voltage output
COIL_R	Right direction coil control voltage output
DROP ARM	Arm dropping control voltage output connector
ENC_MEN	Rotary encoder with button for menu navigation

SETTINGS MENU	
	<p><b>Coils type</b>            There are two options for each coil:</p> <ul style="list-style-type: none"> <li>• NOR – normal coil, during power failure the rotor stays blocked.</li> <li>• REV – reverse coil, during power failure the rotor stays unblocked</li> </ul> <p>Default setting: NOR</p>
	<p><b>Rotor speed</b>            This setting defines the power of the engine that supports the movement of the rotor.            Possible values to choose from: 1-9</p> <p>Default setting: 5            This option is not available in GA and BASIC series gates.</p>
	<p><b>Fire alarm signal function</b>            Fire alarm signal can function in normal closed mode or normal opened mode.</p> <ul style="list-style-type: none"> <li>• NO – normal opened</li> <li>• NC – normal closed</li> </ul> <p>Default setting: NO</p>
	<p><b>Initiating movement</b>            This setting defines if the device should perform the initiating move.            Possible configurations:</p> <ul style="list-style-type: none"> <li>• L – movement in the left direction</li> <li>• R – movement in the right direction</li> <li>• none – no initiating movement</li> </ul> <p>Default setting: none            This option is not available in GA and BASIC series gates.</p>

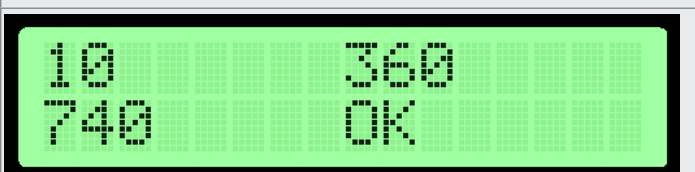
ZERO POSITION CONFIGURATION	
	<p>After entering the configuration mode, set each of the arms in blocked position. Each of the three positions has to be confirmed by pressing the encoder. Display shows the number of zero position which is currently being modified (0, 1 or 2).</p>
	<p>After all three zero positions are set, the display shows saved values. If the values are correct, "OK" message is displayed. If the values are not correct, "Error" message is displayed. This means that the values of zero positions are not saved and the procedure shall be repeated. Regardless of the result of the configuration, after pressing the encoder, settings menu will be displayed.            To save changes, choose the Save &amp; Exit option.</p>

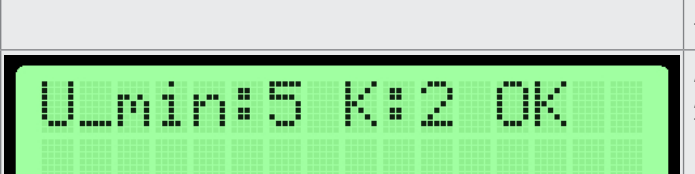
CALIBRATION	
	<p>After choosing the calibration option in the bottom row of the screen the rotor speed is shown. The controller will try to slowly move the device's motor to identify it's parameters.</p> <p>Notice: During the calibration nothing shall interrupt the rotor's movement. Otherwise the procedure has to be repeated.</p> <p>This option is not available in GA and BASIC series gates.</p>
	<p>After the calibration procedure is finished, the identified parameters are displayed. After pressing the encoder, controller returns to the Settings menu.            To save changes, choose the Save &amp; Exit option.</p> <p>This option is not available in GA and BASIC series gates.</p>

## FIRST RUN

In order to provide safety during first run, follow these rules:

1. Before applying power to the device make sure that all cables are connected properly.
2. Wrong connection of the encoder may cause the device to behave in an unpredictable way. Take extra safety precautions.

## DEVICE CONNECTIONS

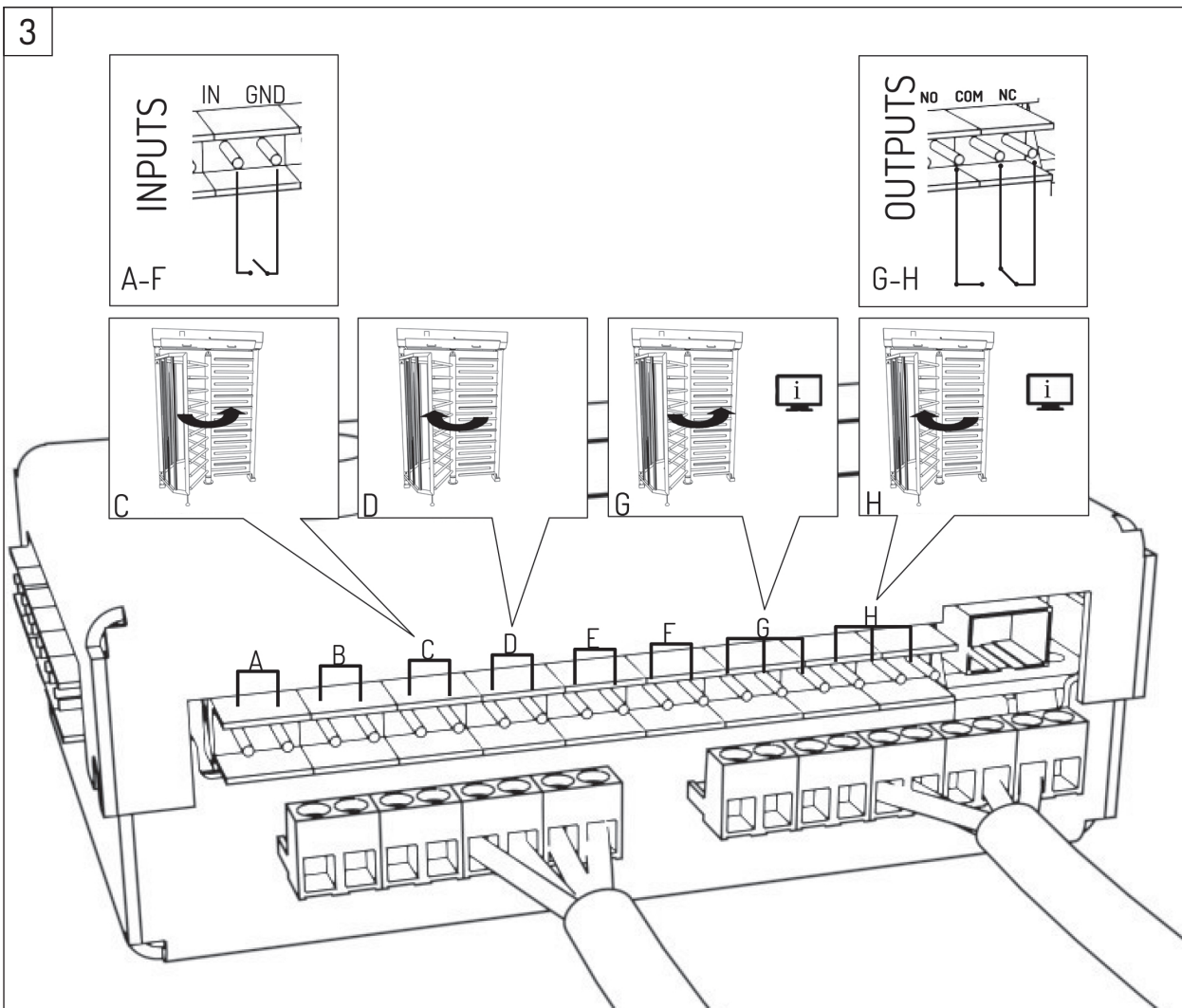
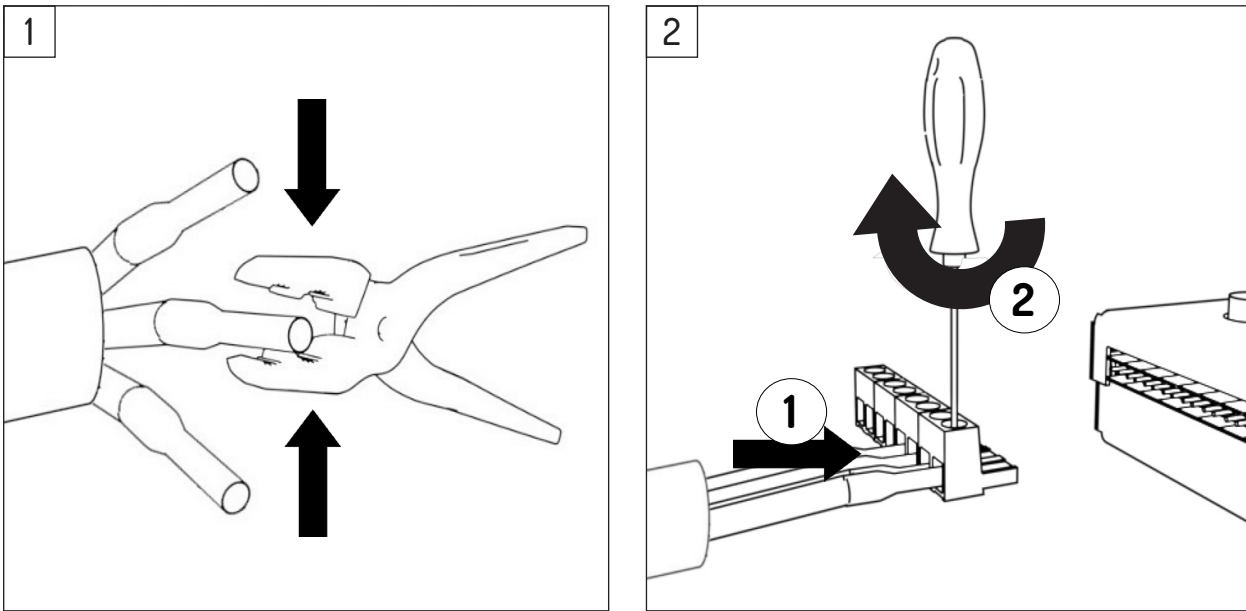

1. Tightening the sleeve terminal on a wire using pliers for electrical installation.
2. Installing the wire in a correct place on the terminal strip.
3. Connecting basic signals to a controller.

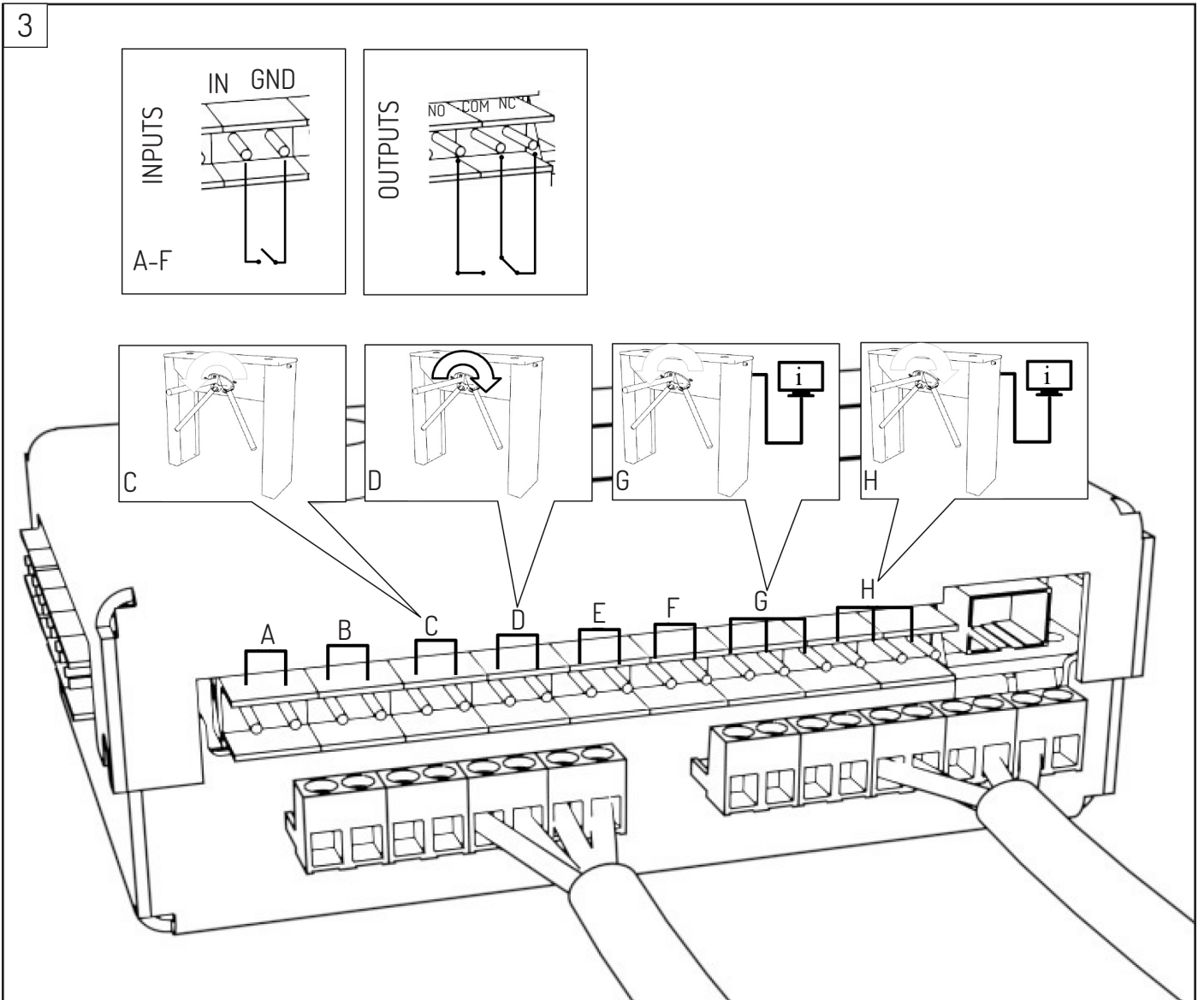
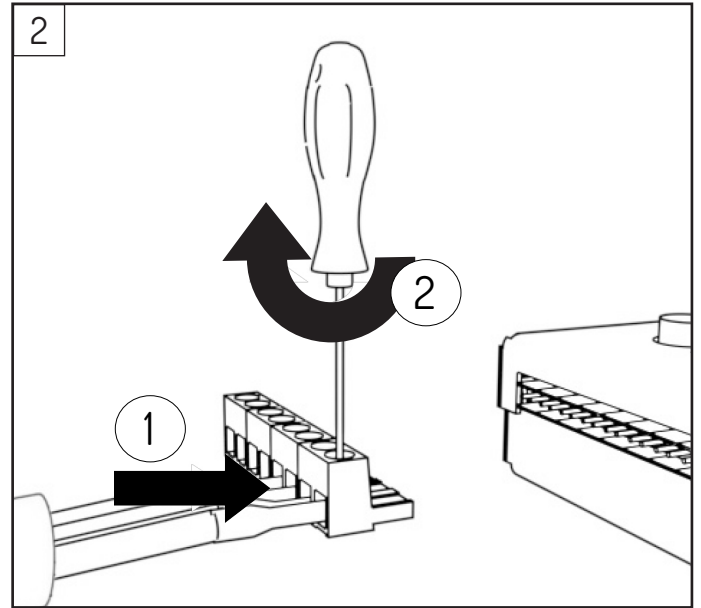
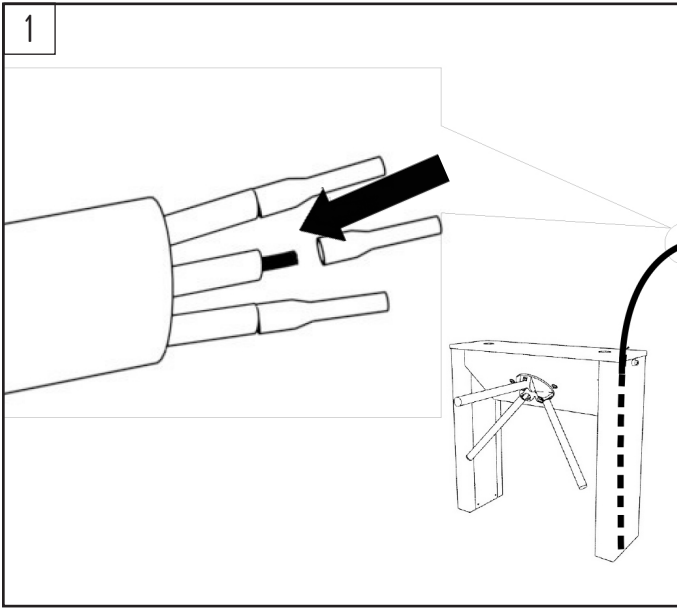

### OUTER CONTROL SIGNALS

### OUTER POWER SOURCE

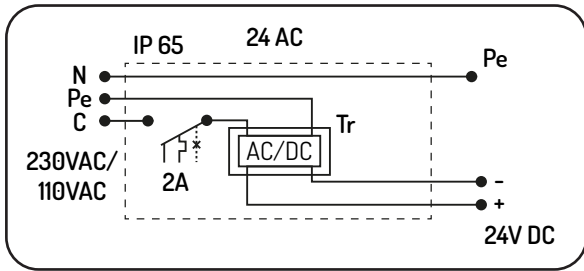
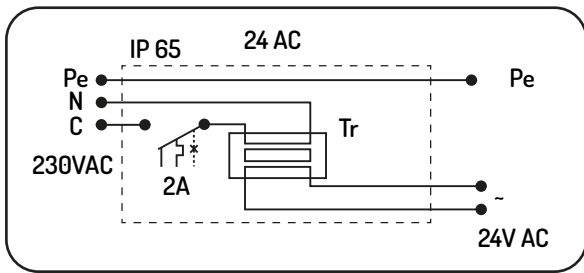

ALTERNATIVE POWER SOURCE

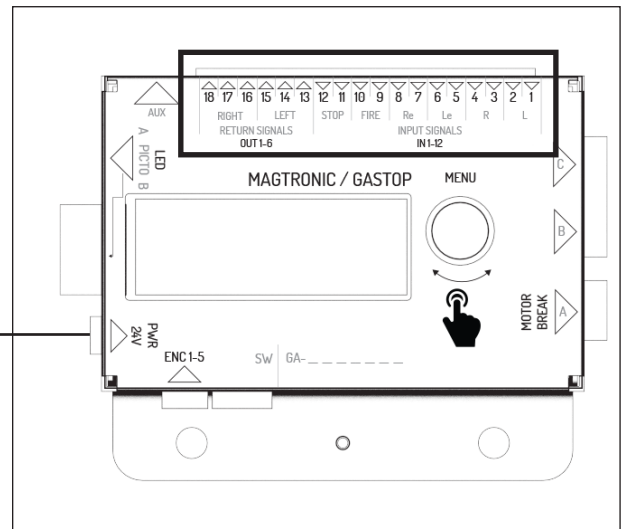

	PIN	DESCRIPTION	ELECTRICAL INFO	CONTROL SCHEME
INPUTS	1	LEFT DIRECTION - INPUT	TTL Hi/Low	
	2	GND	$I_{max} = 1mA$	
	3	RIGHT DIRECTION - INPUT	TTL Hi/Low	
	4	GND	$I_{max} = 1mA$	
	5	LEFT DIRECTION EN. - INPUT (LE)	TTL Hi/Low	
	6	GND	$I_{max} = 1mA$	
	7	RIGHT DIRECTION EN. - INPUT (RE)	TTL Hi/Low	
	8	GND	$I_{max} = 1mA$	
	9	FIRE EMERGENCY - INPUT (FE)	TTL Hi/Low	
	10	GND	$I_{max} = 1mA$	
	11	STOP EMERGENCY - INPUT (SE)	TTL Hi/Low	
	OUTPUTS	12	GND	$I_{max} = 1mA$
13		LEFT RETURN - OUTPUT NO	$I_{max} = 0,5A$	
14		LEFT RETURN - OUTPUT COM	$I_{max} = 0,5A$	
15		LEFT RETURN - OUTPUT NC	$I_{max} = 0,5A$	
16		RIGHT RETURN - OUTPUT NO	$I_{max} = 0,5A$	
17		RIGHT RETURN - OUTPUT COM	$I_{max} = 0,5A$	
18	RIGHT RETURN - OUTPUT NC	$I_{max} = 0,5A$		

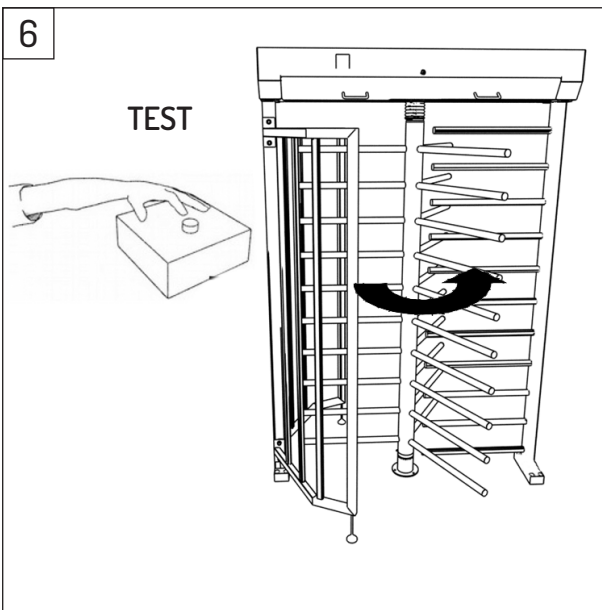
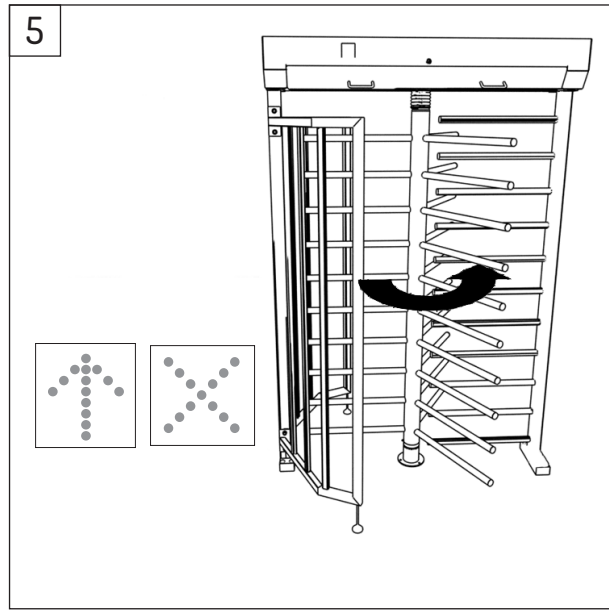
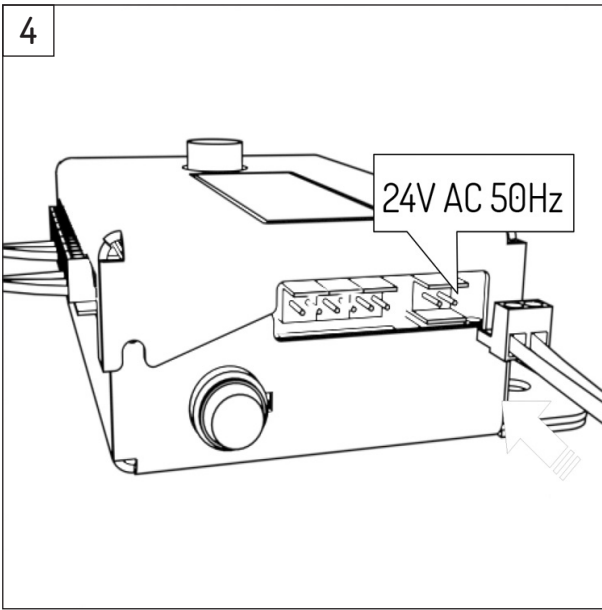

4. Plugging the device to the power supply.
5. Automatic test testing the device efficiency.
6. A test performed with the use of an external device (e.g. a button).