

HT431 FULL HEIGHT TURNSTILE

We understand that your priority is ensuring the safety and security of your premises, employees, and visitors. The HT431 is designed with your needs in mind, offering a comprehensive entrance security solution that is affordable, dependable, and easy to use day-to-day.

When you choose the HT431, you're not just investing in a product--you're choosing peace of mind, knowing that your facility is safeguarded by the most robust and reliable turnstiles on the market. Whether you're managing a critical data center, a high-security government facility, a busy construction site, or a high-volume distribution center, the HT431 delivers the security and dependability you need to keep your people safe.

**USA
MADE**



Made safe and reliable by the revolutionary **ARC Turnstile Mechanism:**
The most heavy-duty and feature-rich turnstile speed control mechanism on the market.

- ✓ Easily integrates with virtually any access control system and software
- ✓ Built to withstand continuous indoor or outdoor use
- ✓ Spacious 31" passage width ensuring comfortable access for everyone
- ✓ Affordable upfront investment with low maintenance requirements
- ✓ Optionally installed by our nationwide network of partner installers

Dependable and Safe Operation

- ARC speed controller ensures turnstile arms spin at a safe velocity that adjusts to user push force
- Mechanical anti-entrapment technology
- Tamper proof fully welded exterior construction
- Field reversible from fail safe (unlocking upon power failure or alarm condition) to fail secure (locking upon power failure or alarm condition)
- Dedicated I/O inputs for fire safety systems integration

Great For

- Credential card access into and out of facilities
- Perimeter control in fence lines
- Employee and visitor access control
- Autonomous time and attendance tracking
- One-way traffic enforcement (entrance only/exit only)
- Unmanned entrance security checkpoints

Typically Found At

- Distribution centers
- Data centers/server farms
- Secured government and military facilities
- Manufacturing plants
- Corporate facilities

Systems Integration

- I/O (dry contact) integration makes integrating access control and fire safety systems a breeze

Available Finishes

- Hot dipped galvanized steel (indoor or outdoor use)
- Powder coat over raw steel (indoor use)
 - Choice of 2 colors per turnstile
- Powder coat over galvanized steel (indoor or outdoor use)
 - Choice of 2 colors per turnstile

Operating Modes

- Bidirectional access control: card access in/card access out
- One-way access control: card access in/free spinning out
- Free passage: free entry/free spinning exit
- Exit only: no entry/free spinning exit
- Entrance only: free spinning entry/no exit

Optional Addons

- Card reader mounting plates
- Padded turnstile arm safety sleeves
- Manual key overrides
- LED passageway indicator lights
- Anti-climb stainless steel full and half canopies
- Home position switches for access control integration
- Heavy-duty lock bar with included padlock
- Backup battery
- Cold weather package
- Self-supported canopies to go overtop entire turnstile array

Power Supply Specs

- Input: 100-230VAC (1.6 amp), 50-60hz
- Operating voltage: 24VDC (3.0 amp)
- All components UL recognized



HT431 Dimensions

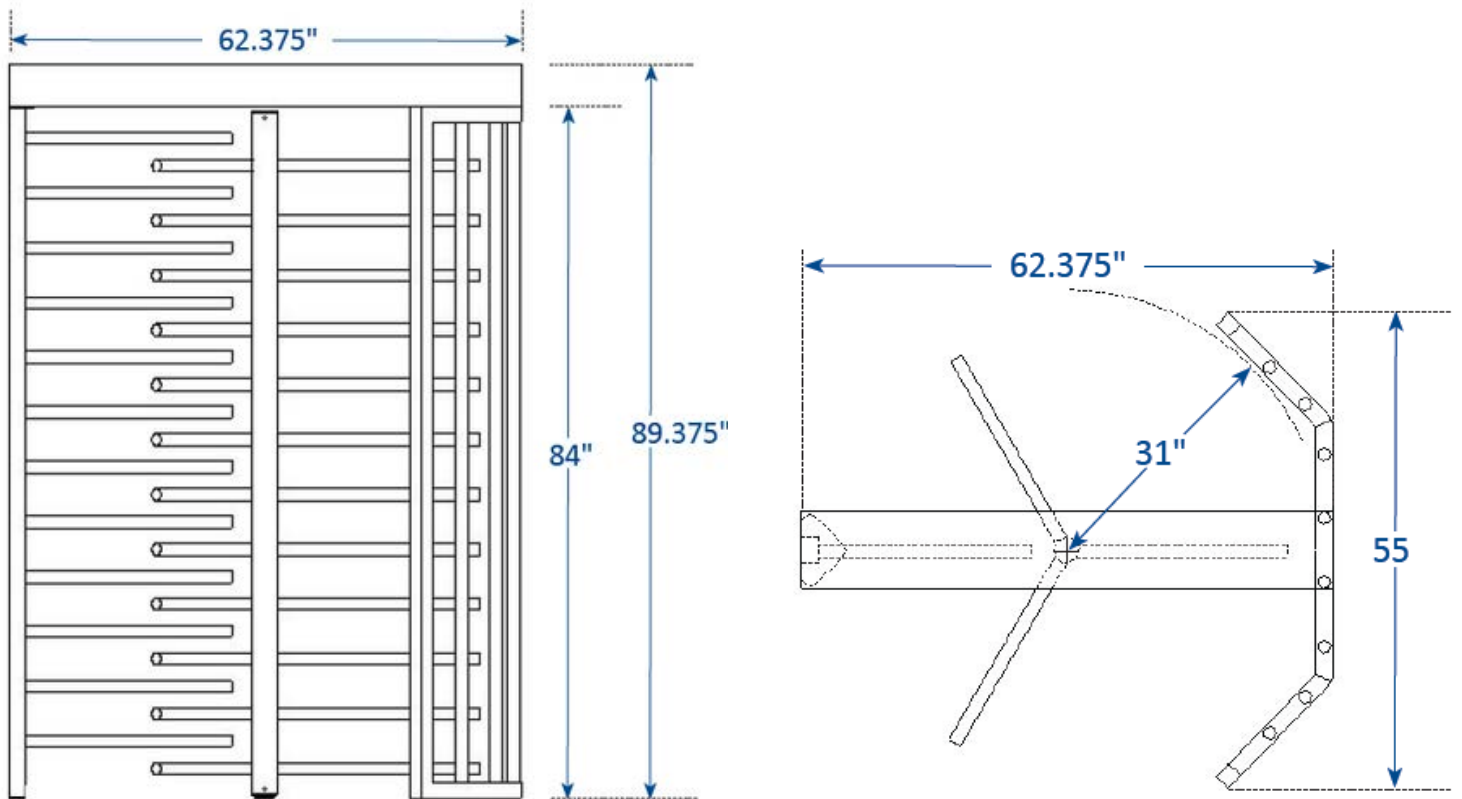

NEW AND IMPROVED ARC Turnstile Mechanism

Leading the way in turnstile innovation, we are proud to introduce our new ARC (Automatic Rotational Control) full height turnstile mechanism—setting a new standard as the most durable and feature-packed turnstile control head on the market.



USA
MADE

WHY THE CHANGE?

Our goal has always been to provide our customers with the best and most dependable entrance solutions at realistic prices. As technology improves, we want to make sure our turnstiles do too. That's why we developed our ARC mechanism so our customers could enjoy a long-lasting, low-maintenance turnstile that they could easily integrate with their access control systems. This new mechanism also reduces failure rates due to misuse/hard use, resulting in fewer repairs and lower lifetime ownership costs.

WHAT'S NEW?

- ✓ **Field Reversibility:** easily change your turnstile configuration on the fly if your access control needs change over time. No need to send to Hayward for reconfiguration.
- ✓ **Comprehensive Speed Control:** our ARC speed controller ensures a safe rate of turnstile arm rotation throughout the entire rotation, reducing risk of misuse and damage.
- ✓ **Reinforced Locking Components:** coupled with our comprehensive speed control, these beefed up locking components make our turnstiles virtually unbreakable.
- ✓ **Enhanced Power Supply:** a larger, stronger power supply output allows you to now power neighboring ADA gates and electronics right from the turnstile power supply.
- ✓ **Dedicated Inputs and Outputs:** making integration easier than ever. Dedicated inputs for fire ensures simple integration with life safety systems.

WHICH PRODUCTS?

HT431 Single Full Height Turnstile | HT431T Tandem Full Height Turnstile
HT431P Portable Full Height Turnstile