

Installation Guide

Mars-S100 Series

Version: 1.2

1 Installation Requirements

1. It is recommended that the turnstile must be installed on a horizontal solid platform with a height of 50mm to 100mm.
2. It is also recommended that the turnstile should not be used in the corrosive environment.
3. Make sure that the ground wire of the system is being securely connected to avoid any personal injuries or other accidents.
4. After installation, check if the connection has been done correctly at the connecting points of the ground wire, at the connector assemblies and wiring points of the circuits. Additionally, inspect each movable part of the turnstile to ensure proper connection. Tighten any loose nuts, screws, or other fasteners quickly to prevent failures due to prolonged operation.

2 Installation Environment

The installation position of the turnstile depends on its size. A distance of 100mm between the turnstile and the wall needs to be reserved for ease of opening the top lid of the turnstile to perform maintenance and adjustment. The reference figure is shown below:

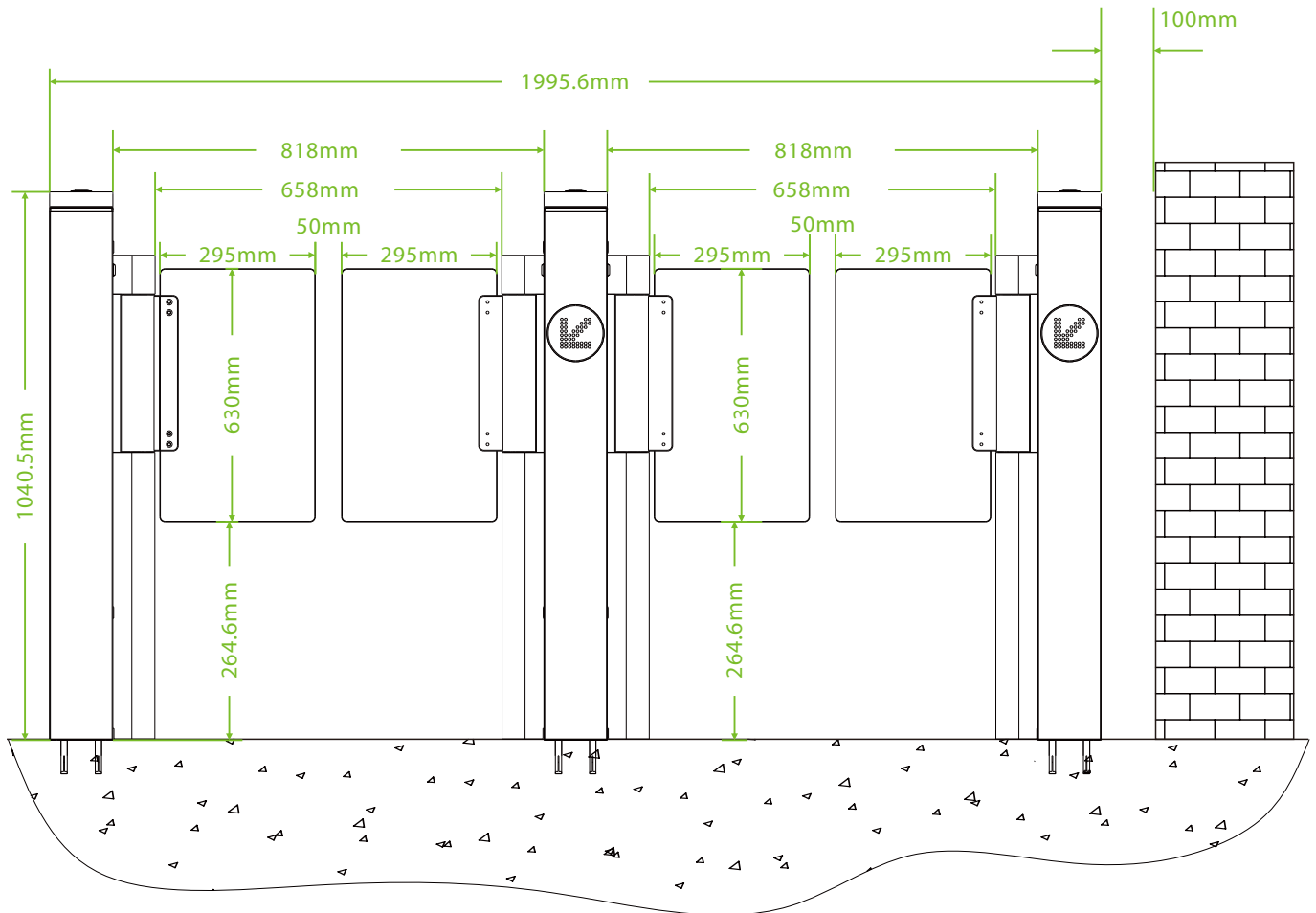

3 Preparation

The following items are required before installing the Mars-S100:

- **A Screwdriver:** To remove or install the screw on the device.
- **A Pencil:** To mark the device size and the screw hole.
- **A Electric Drill:** To drill holes in accordance to the marked screw holes.
- **A Wrench:** To secure the M12 expansion screw on the device.
- **A Tapeline:** To measure the dimensions that need to be measured during the installation of the device.
- **A Hex Wrench:** To remove or install the screw on the device.
- **Cutting Machine:** To cut the road and lay cables.

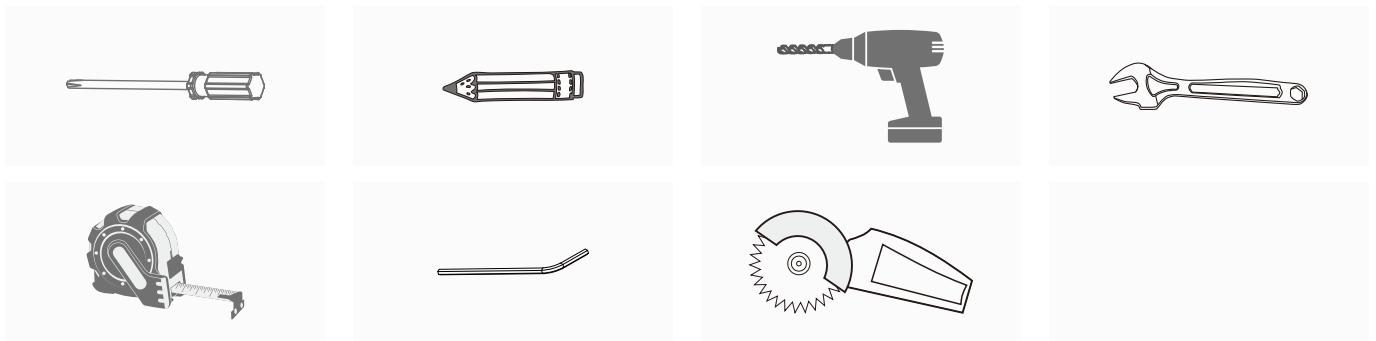

Note: Except for the hex wrench, all other tools should be prepared on ly on your own.

4 Installation

1. Place the turnstile at the installation location.

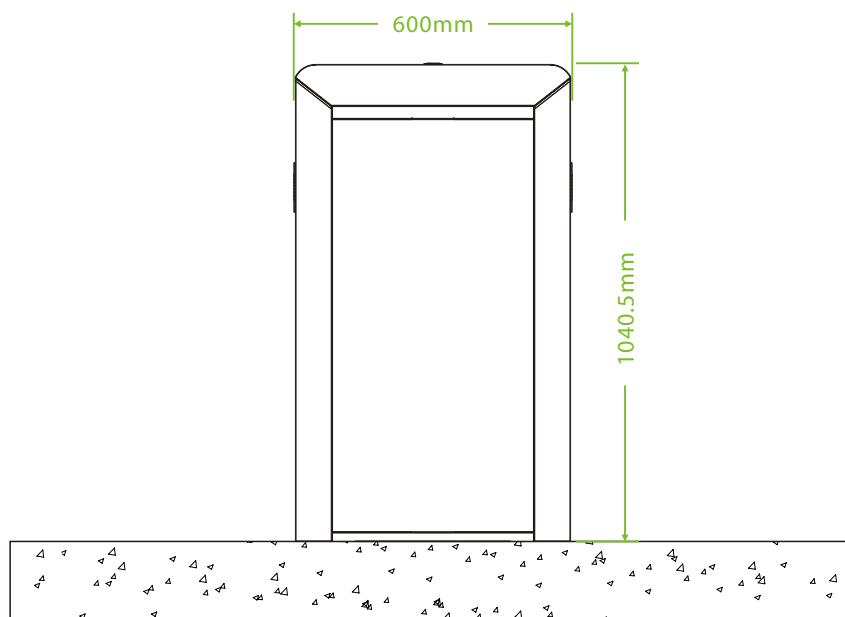

2. Open the chassis of the turnstile with the key and then remove the chassis cover.

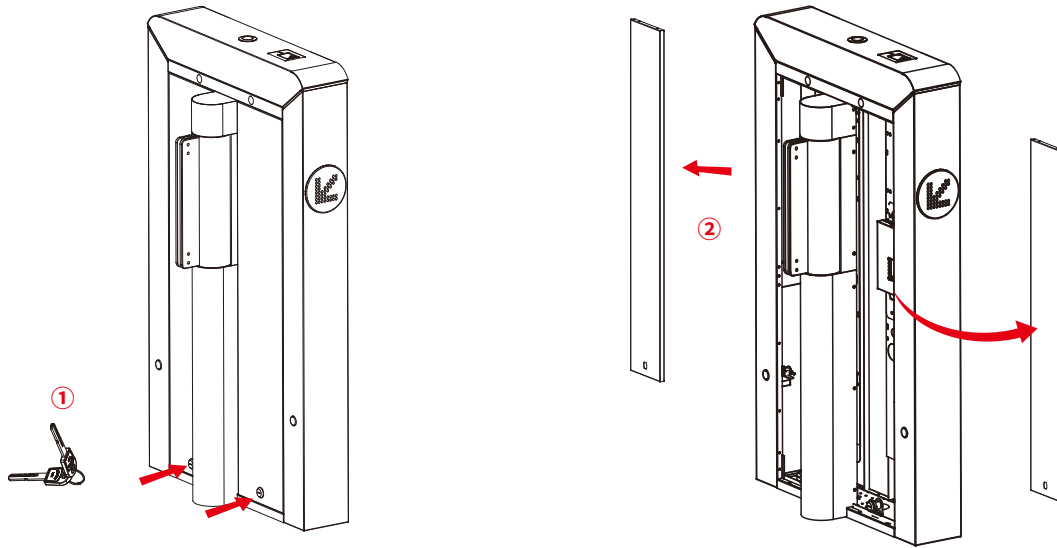

3. Use a pencil to mark the holes on the turnstile.

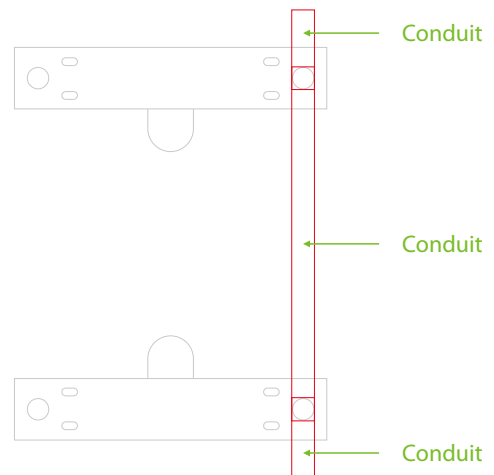
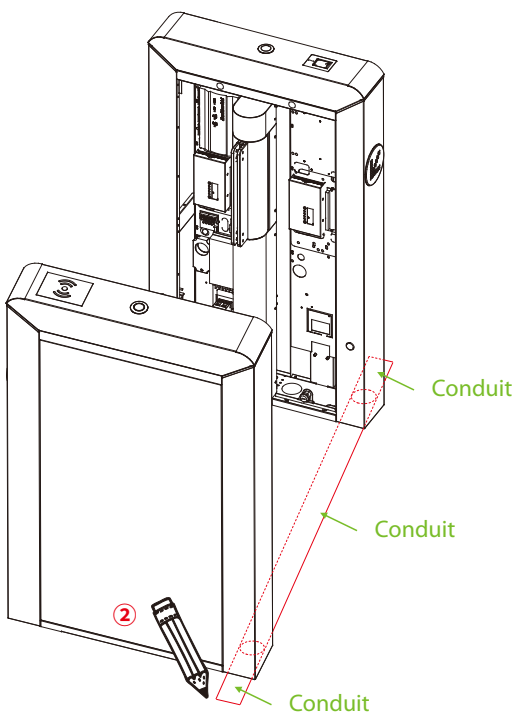
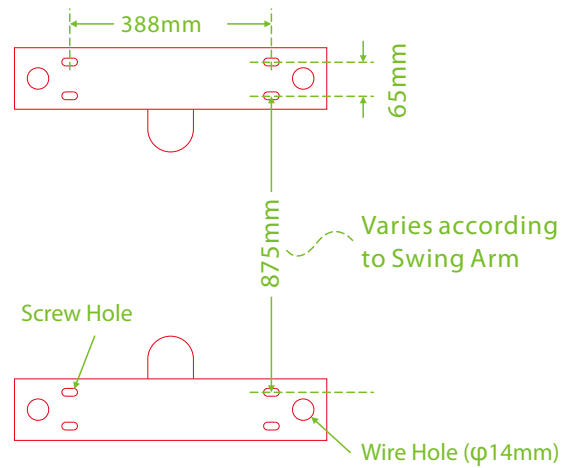
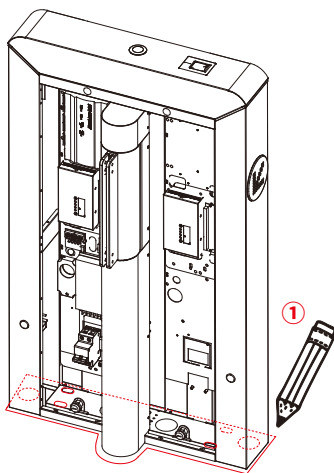

4. Remove the turnstile and use an electric drill to drill holes according to the markings.

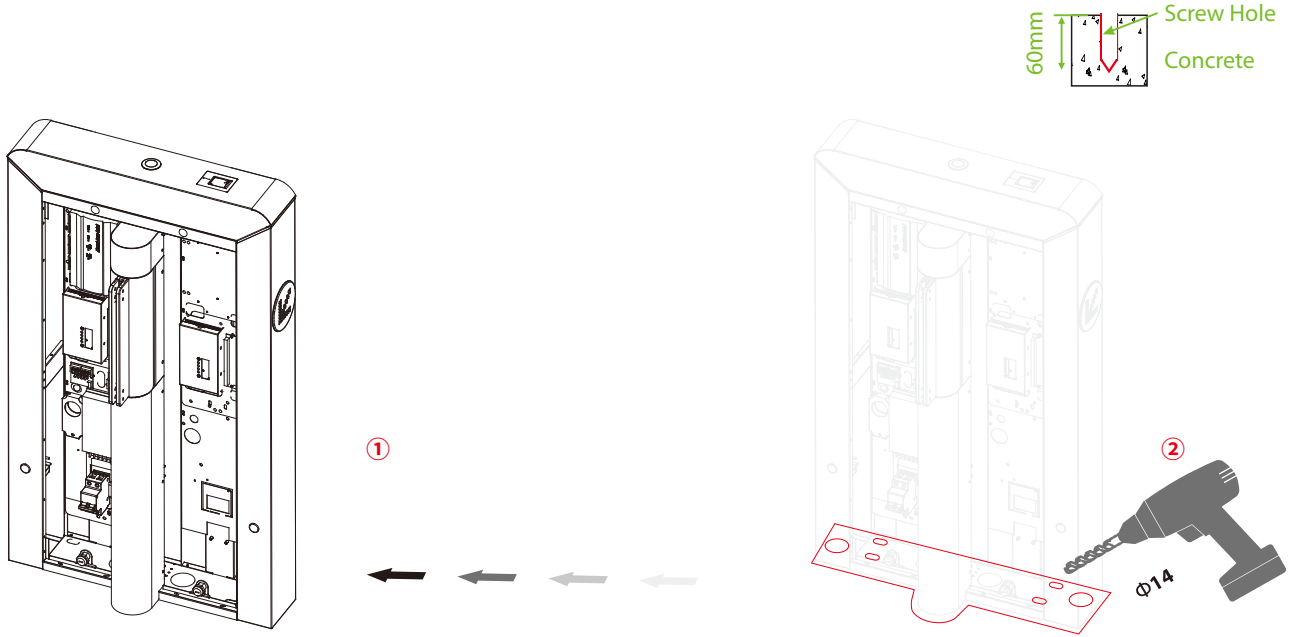

5. According to the wire hole, a cutting machine makes a conduit that is 23mm wide and 60mm deep.

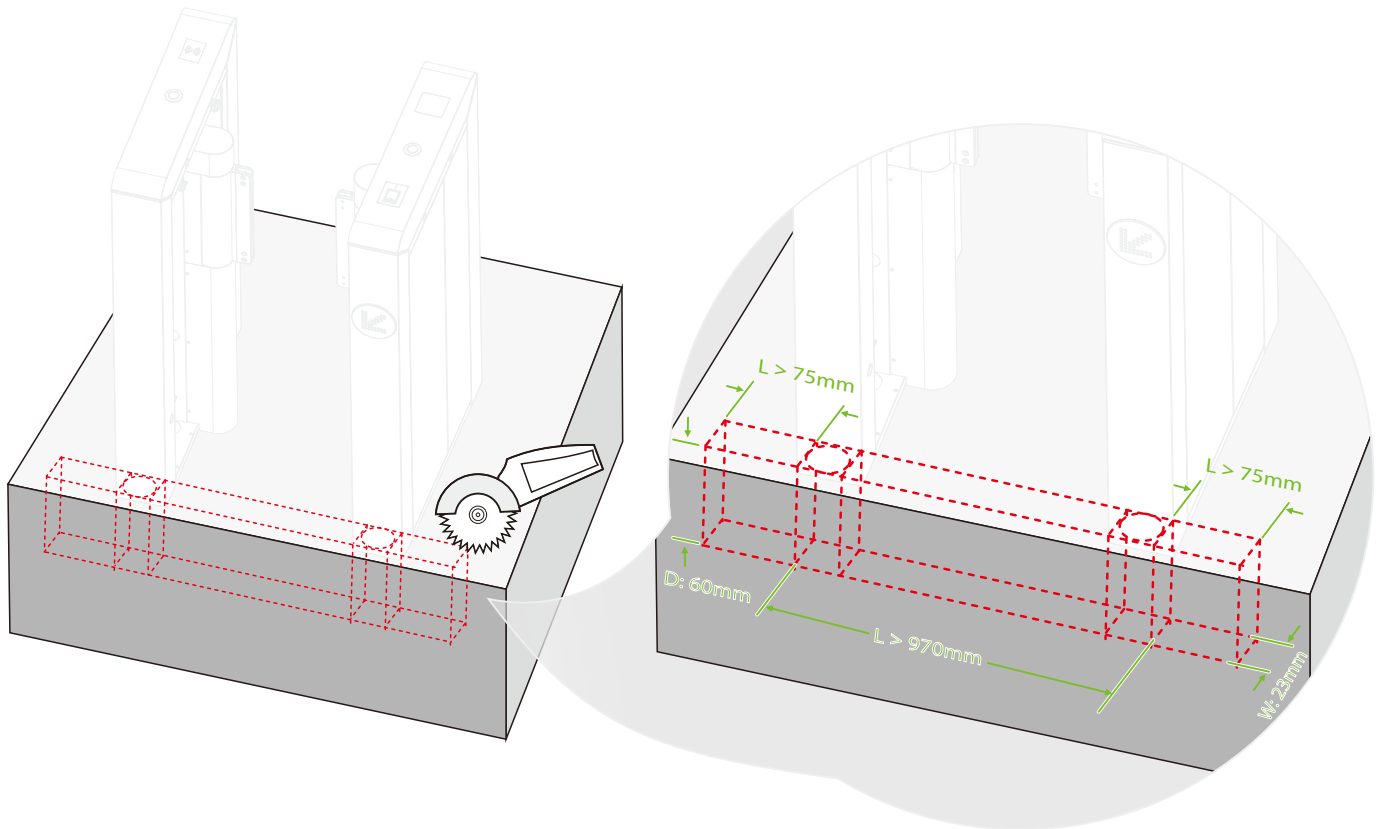

6. Clean up the debris and dust after drilling, and then place the turnstile back on the installation site. Check if the drilled holes align with the mark on the turnstile.

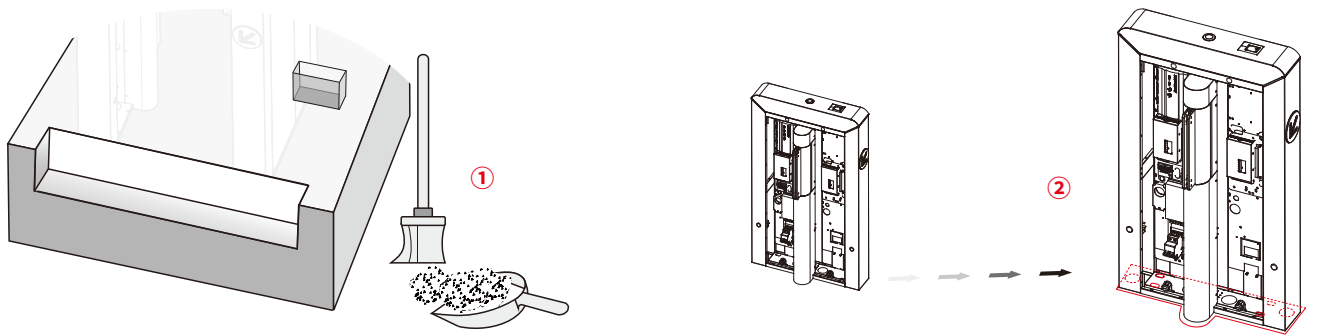

7. Put \varnothing 20mm PVC pipes, and insert Ethernet, Tether Cable and Power Cable through the pipe lines, and then pour the concrete to fill the conduit. **Note:** The strong and weak powers shall be laid separately.

— \varnothing 20mm PVC pipe
 — Power Cable
 — Ethernet
 — Tether Cable

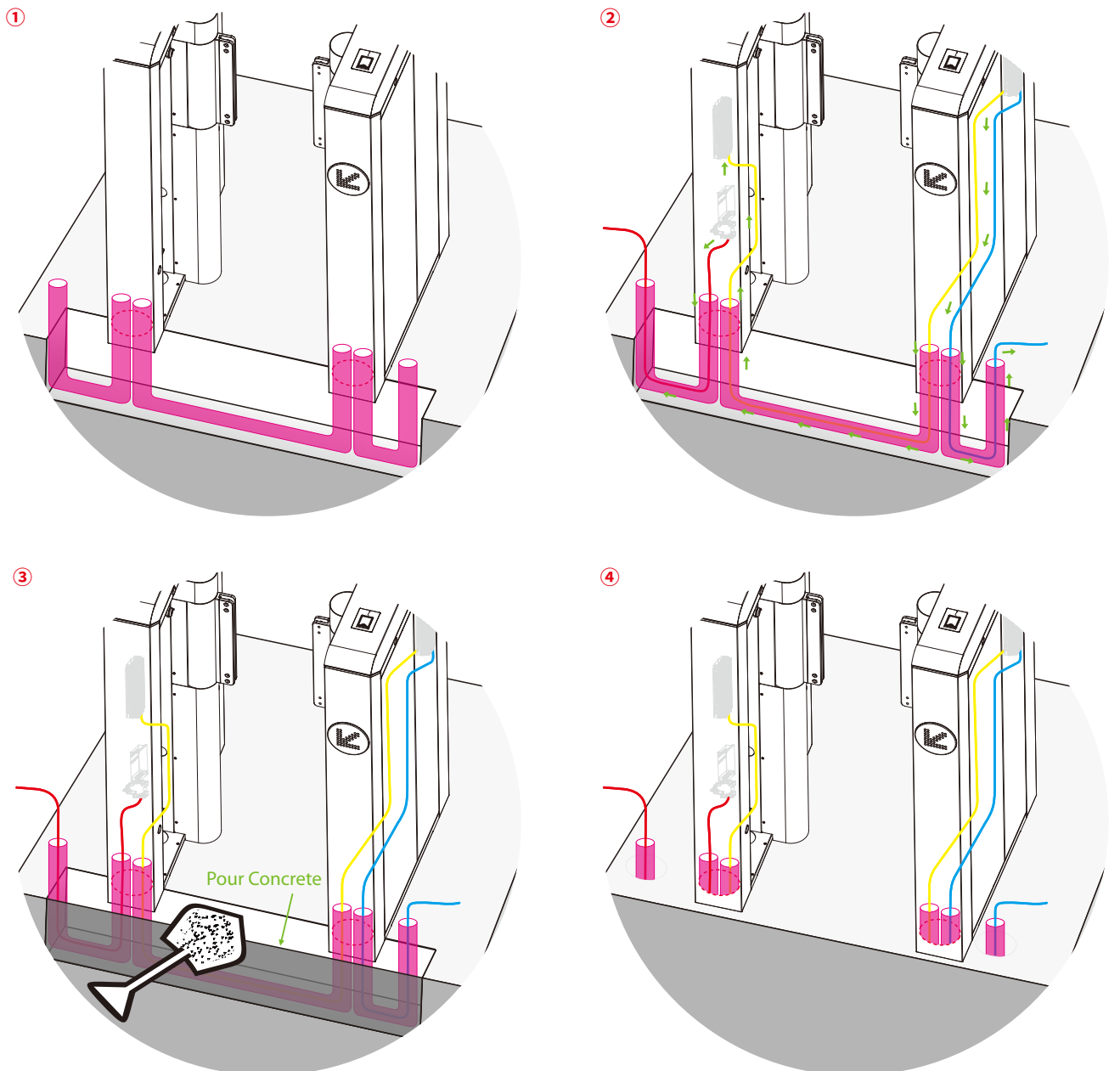

8. Align the turnstile with the drilled holes. Then, insert the bolts accordingly and fix them with a wrench. Finally, insert the washers, and the nuts, then tight them with wrench.



Bolt

①

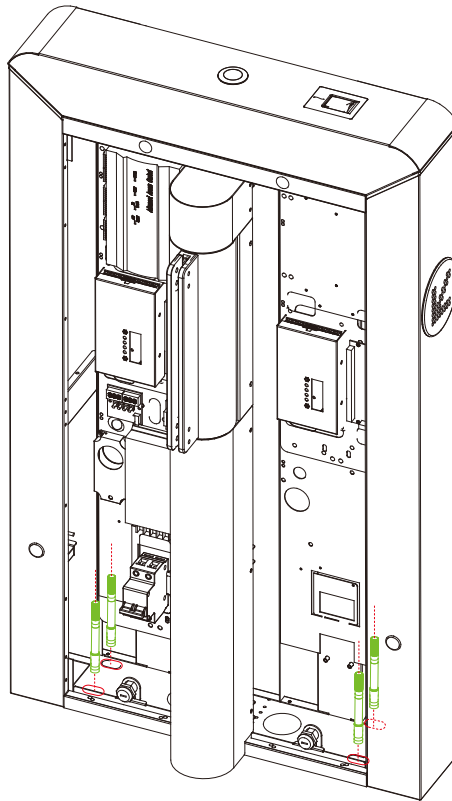

⊕ X4

Nut

⊙ X4

Washer

②

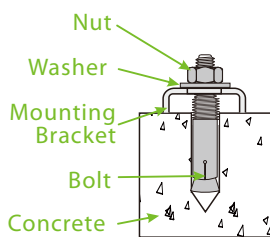
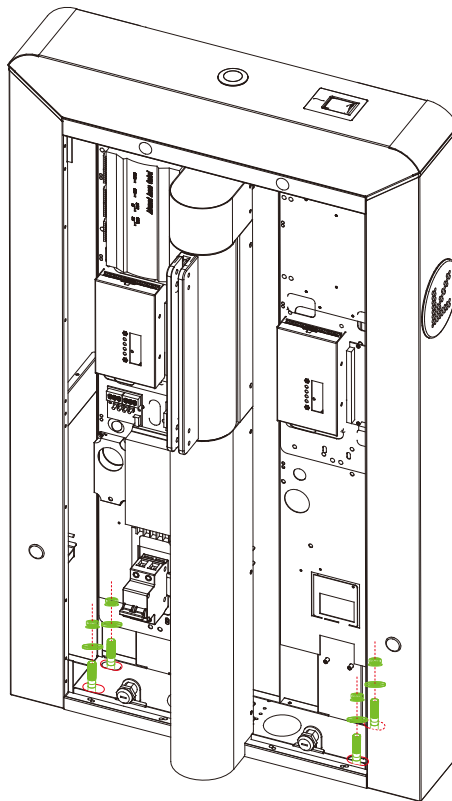

Note: Before inserting the bolt, the user must disconnect the power and Ethernet cables from the machines and place them into the conduit.

9. Close the chassis covers of the turnstile and use the key to lock it.

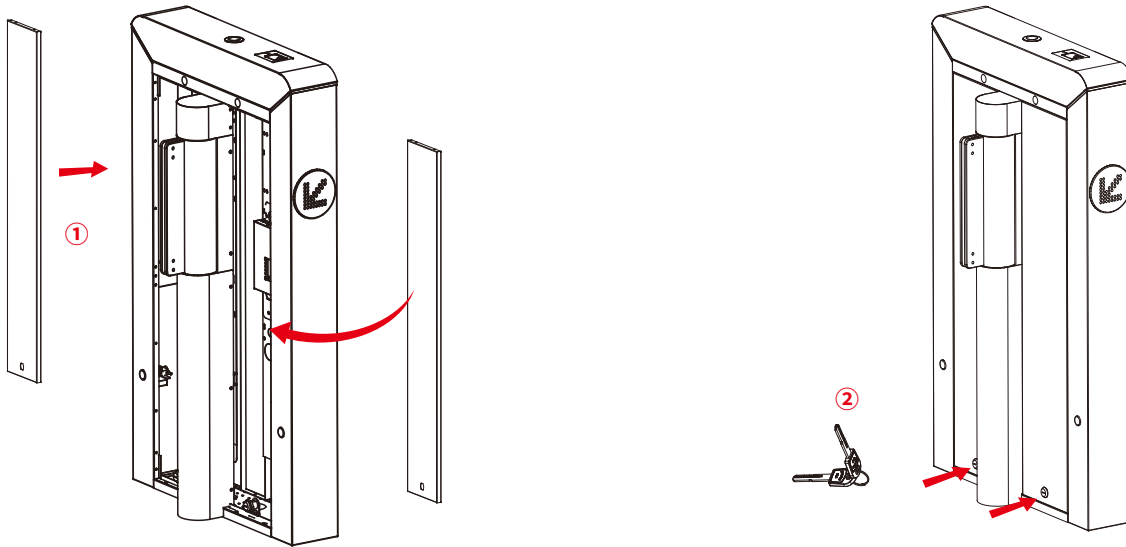

10. Assemble the swing arm by yourself. Refer to the diagram below for installation instructions.
Note: The swing arm is already pre-installed in the factory.

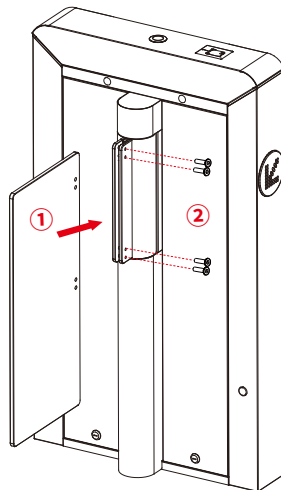

11. We suggest marking a warning line on the floor to remind the user, when installation is being completed. It reminds the user to wait outside the warning line until the previous user have completed the verification process and passed through the turnstile.

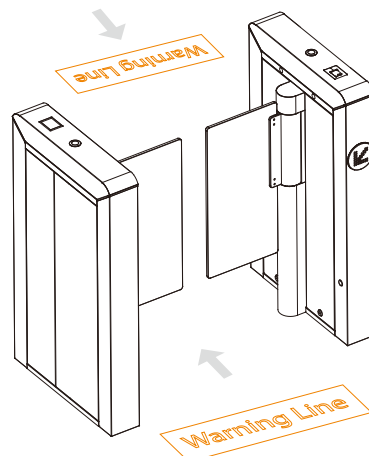

5 Wiring Diagram

