

Installation Guide

OTSG9000/SBTL8000 Series Swing Barrier

Applicable Model(s): OTSG9000, OTSG9011, OTSG9022, OTSG9033, OTSG9200, OTSG9211, OTSG9222, OTSG923 SBTL8000, SBTL8200, SBTL000WP, SBTL8200WP

Version: 1.0

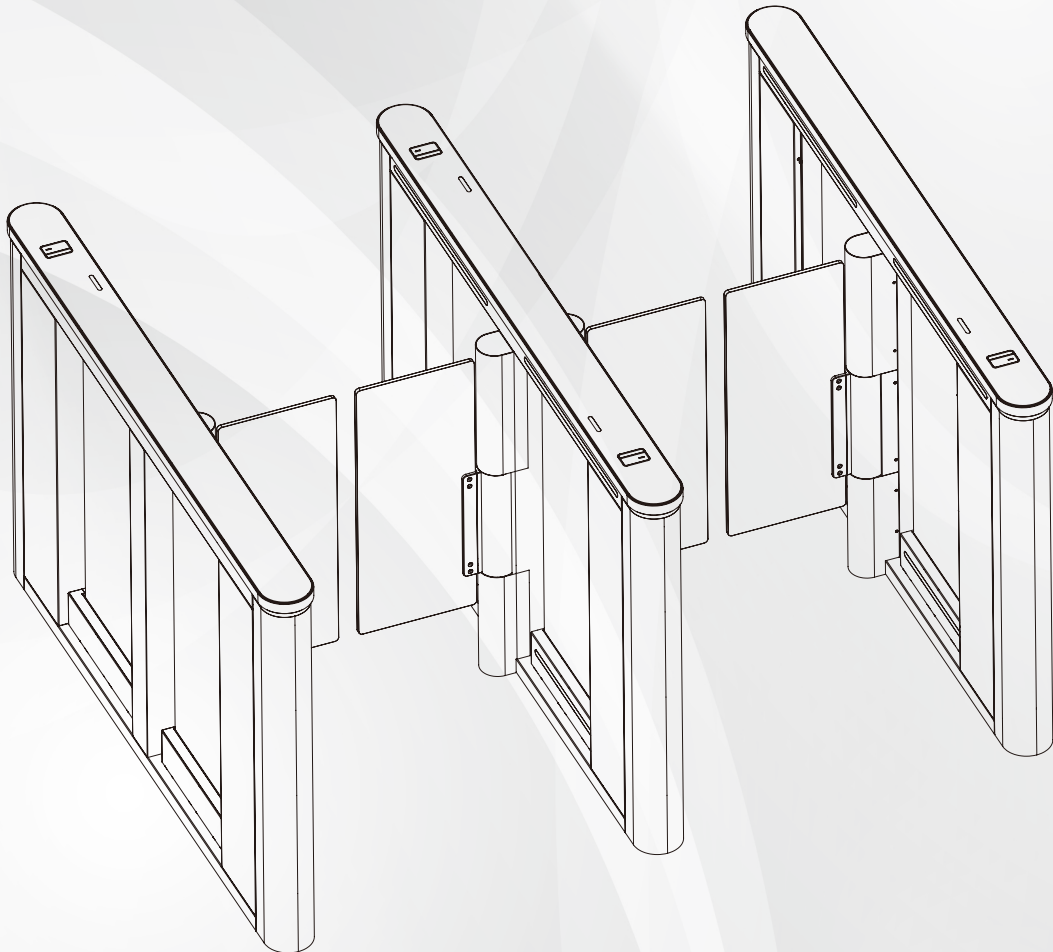

Due to regular upgrades of systems and products, the manufacturer does not guarantee exact consistency between the actual product and the written information in this manual.

Revision History

Revision	Date	Author	Reviewer	Description
V1.0	12/08/2025	Julia.Huang		Original Document

1 Overview

SBTL8000 Series

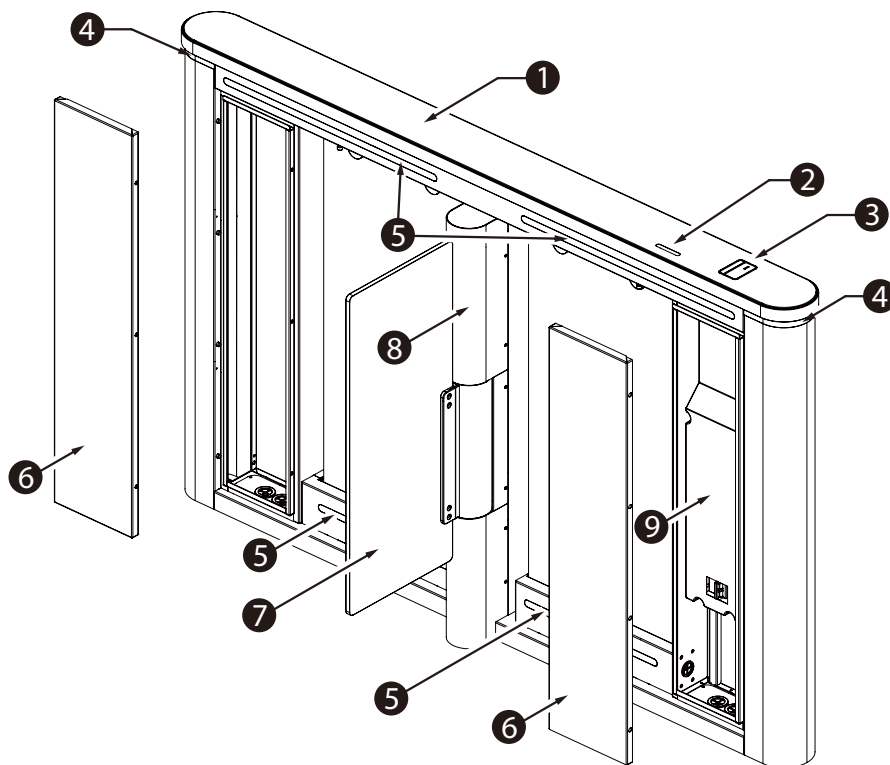

SBTL8200 Series

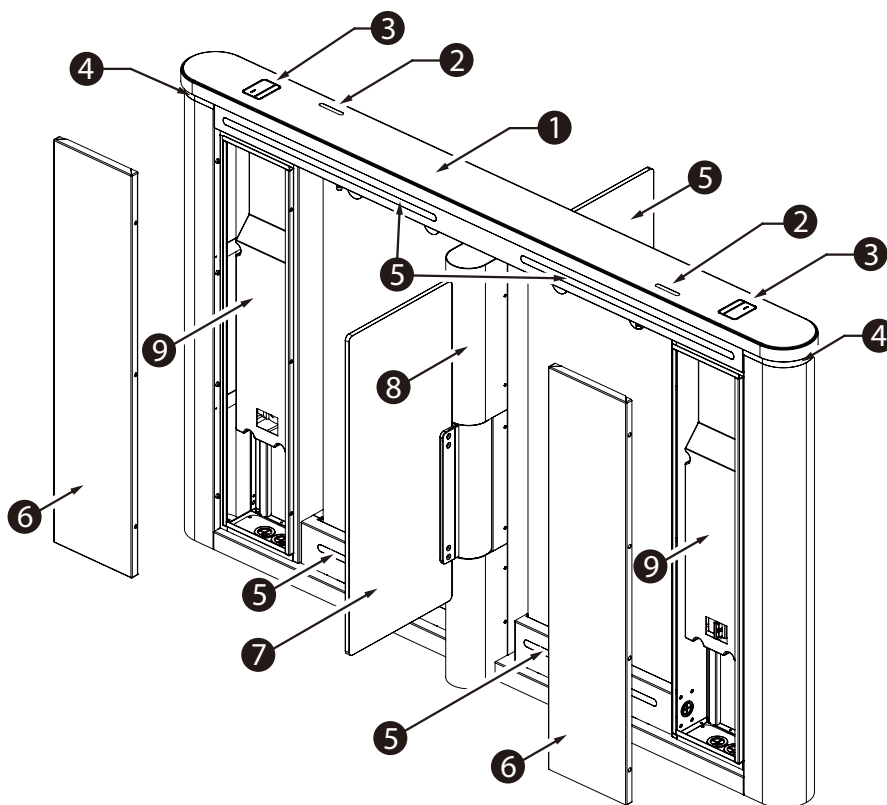

- ① Cover Plate
- ② Traffic Indicator
- ③ Card Reading Area
- ④ Visual Indicator
- ⑤ Infrared Sensor
- ⑥ Chassis Cover
- ⑦ Door Leaf
- ⑧ Core Component
- ⑨ Waterproof Cover for Electrical Controls

2 Dimensions

SBTL8000 Series

Unit: mm

Front View

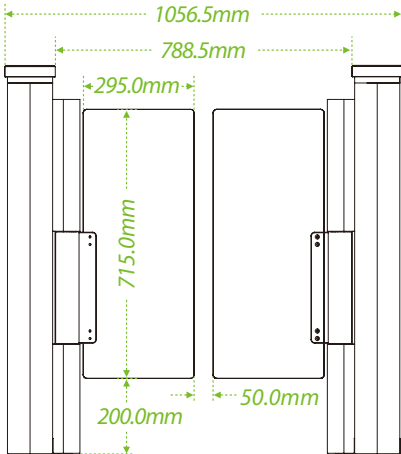

Side View

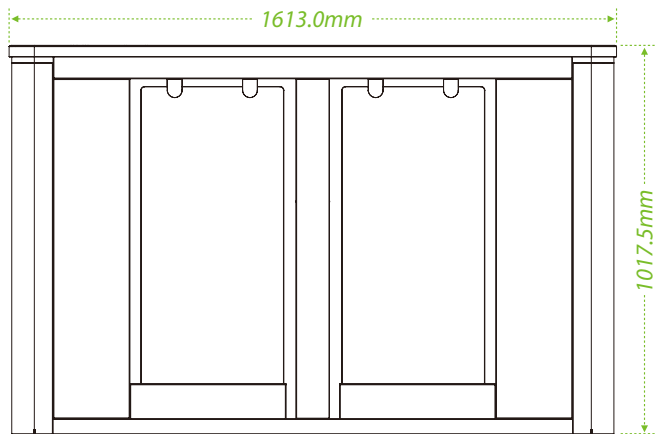

Top View

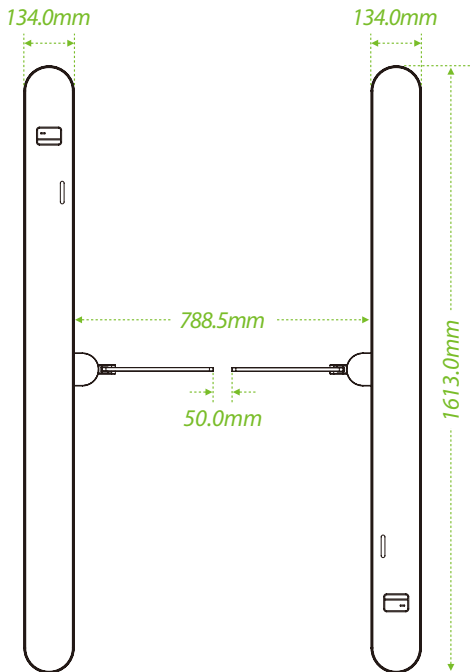

Bottom View

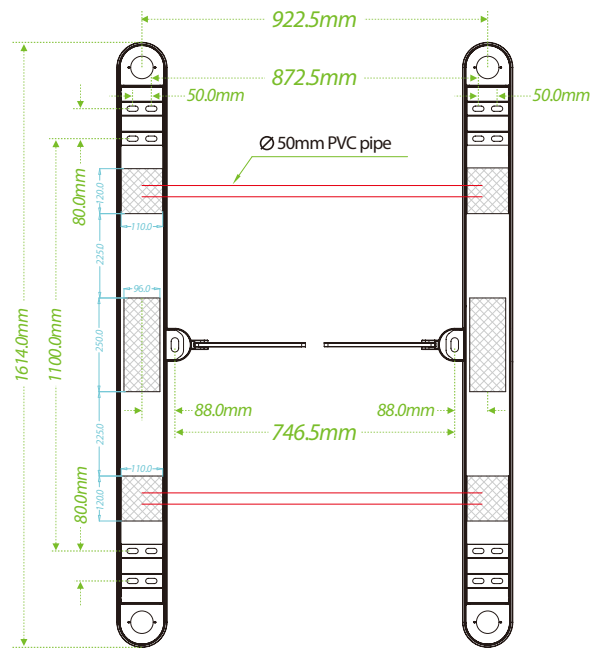

(Note: applies to IP65 rated models: SBTL8000WP and SBTL8200WP. Dimensions at: 1613*134*1031.5mm).

SBTL8200 Series

Unit: mm

Front View

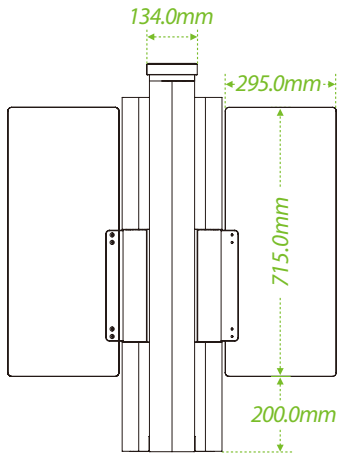

Side View

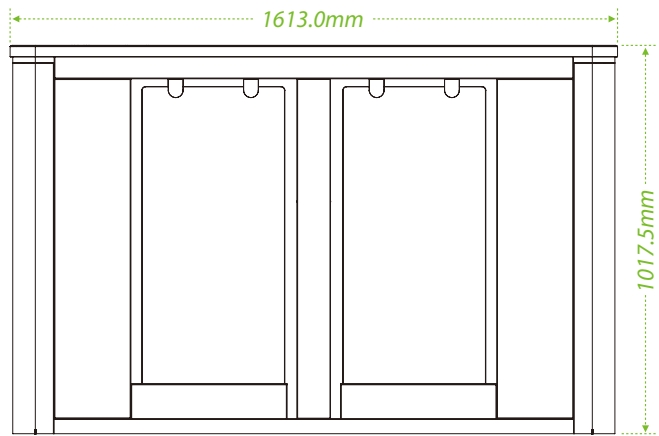

Top View

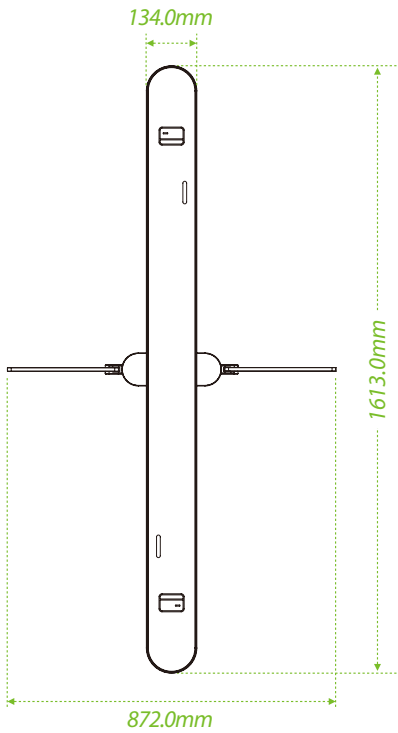

Bottom View

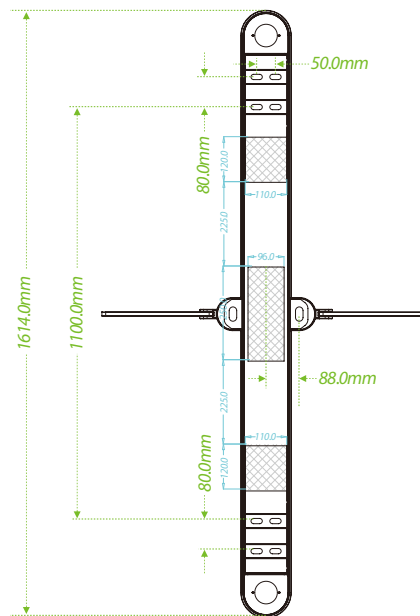

(Note: applies to IP65 rated models: SBTL8000WP and SBTL8200WP. Dimensions at: 1613*134*1031.5mm).

3 System Composition

The SBTL8000 Series and SBTL8200 Series can be combined to form a single, dual or multi-lane system, allowing the user to select the appropriate swing arm size according to actual needs. It should be noted that SBTL8200 Series needs to be used in conjunction with SBTL8000 Series.

Unit: mm

● Single-lane

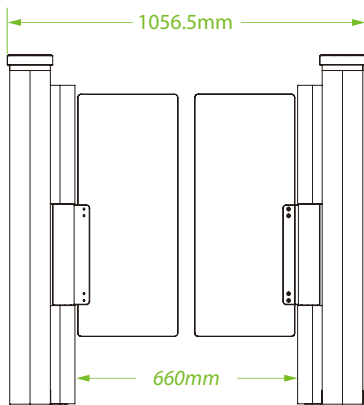

● Wide-lane (Optional)

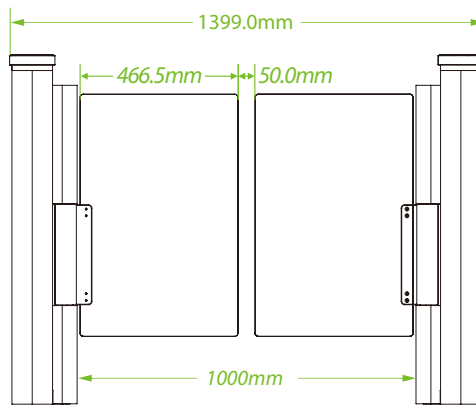

● Dual-lane

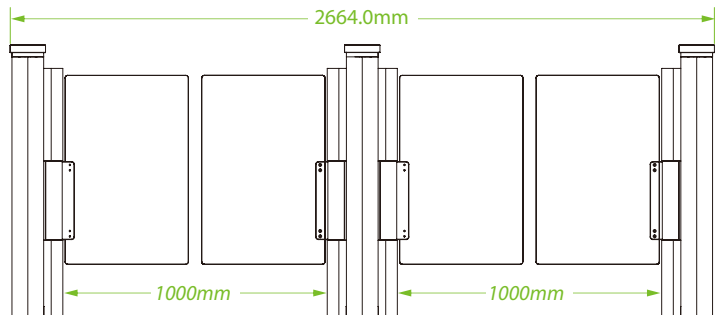
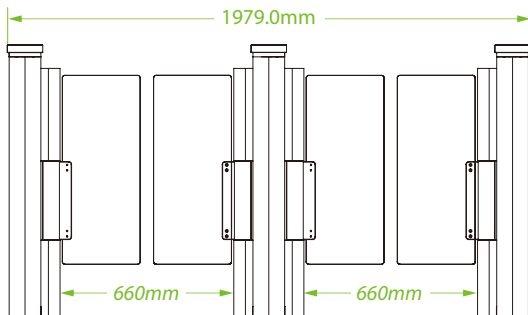

● Multi-lane

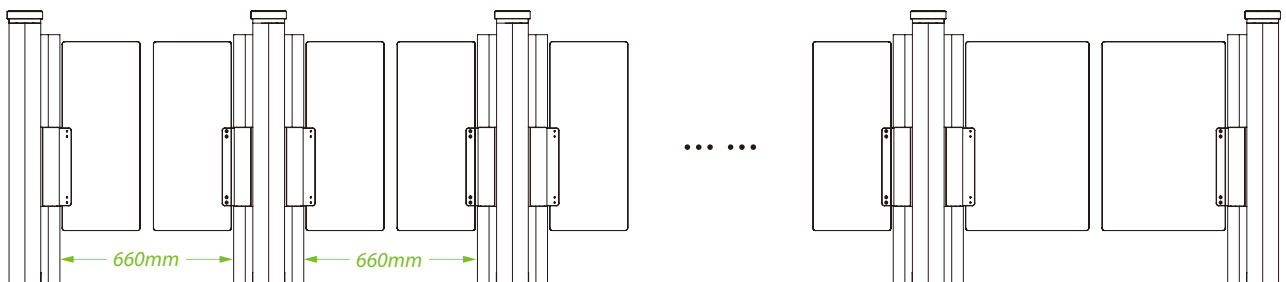

4 Wiring

● Single-lane wiring

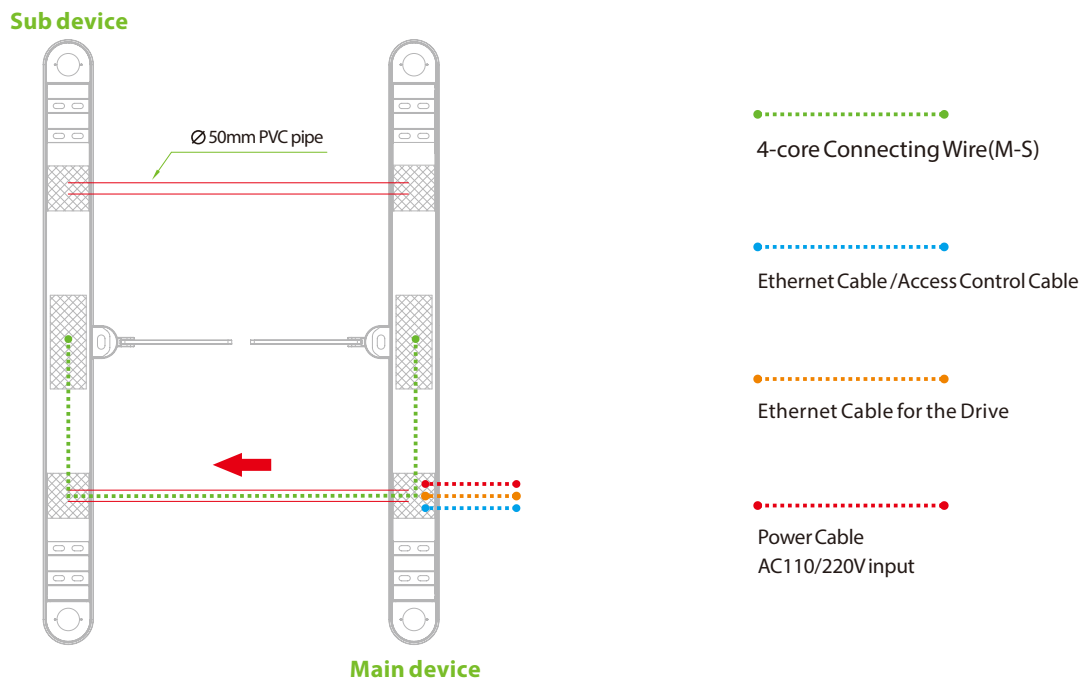

● Dual-lane wiring

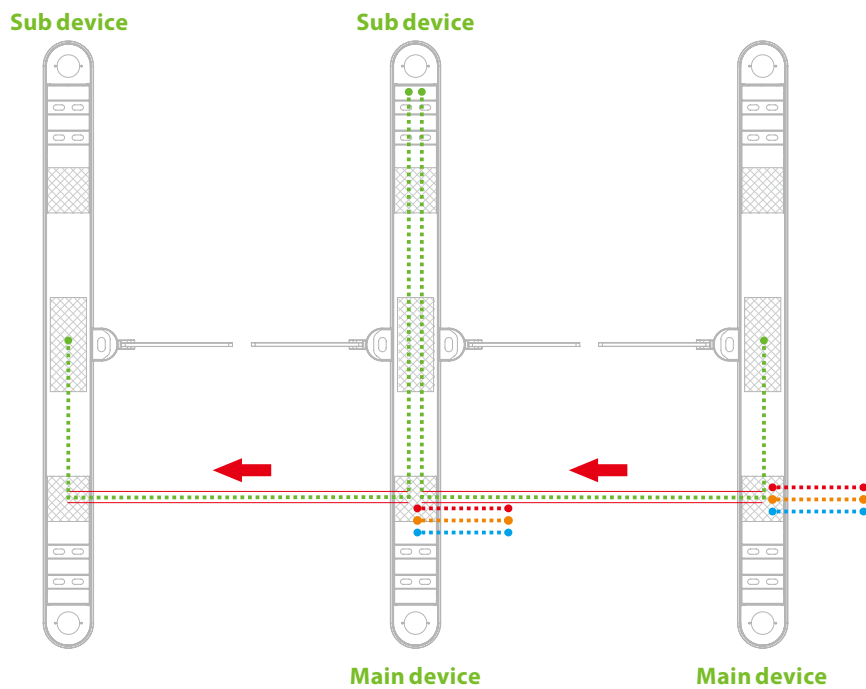

Remarks: The multi-lane wiring method is similar.

5 Installation Requirements

1. It is recommended that the turnstile must be installed on a horizontal solid platform with a height of **2.0" to 3.9"(50mm to 100mm)**.
2. It is recommended that the turnstile should not be used in the corrosive environment.
3. Make sure that the ground wire of the system is securely connected to avoid personal injuries or other accidents.
4. After installation, check if the connection has been done correctly at the connecting points of the ground wire, at the connector assemblies and wiring points of the circuits, as well as at each movable part of the turnstile. Any loose nuts, screws and other fasteners should be tightened in time to avoid any failures caused by long-time operations.

6 Installation Environment

1. Before installation begins, prepare installation tools, check the device and the accessories, and clear the installation base.
2. Make sure that the appliance is mounted on a concrete surface or other non-flammable surfaces.
3. The installation position of the turnstile depends on its size. A distance of **3.9"(100mm)** between the turnstile and the wall needs to be reserved for ease of opening the top lid of the turnstile to perform maintenance and adjustment. The reference figure is shown below:

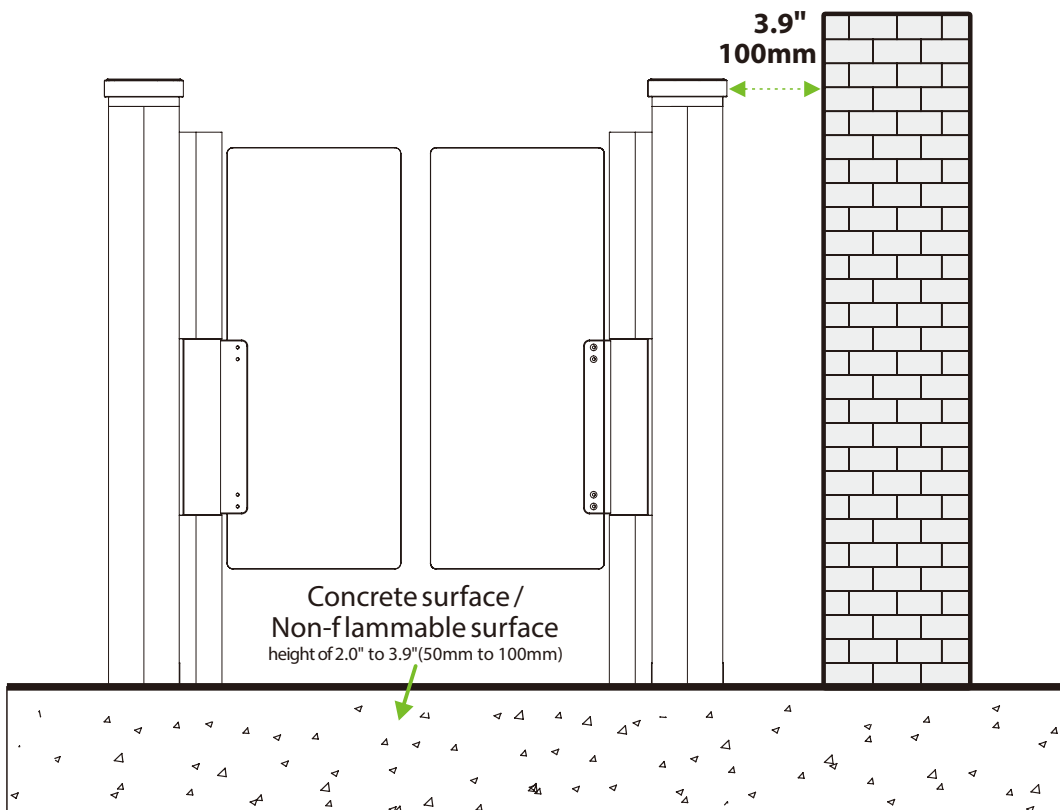

7 Installation Cabinet

Step 1 Remove the Chassis Cover and Cover Plate

1. Use a screwdriver to loosen the six fixing screws at the indicated locations, then remove the chassis cover in the direction shown.

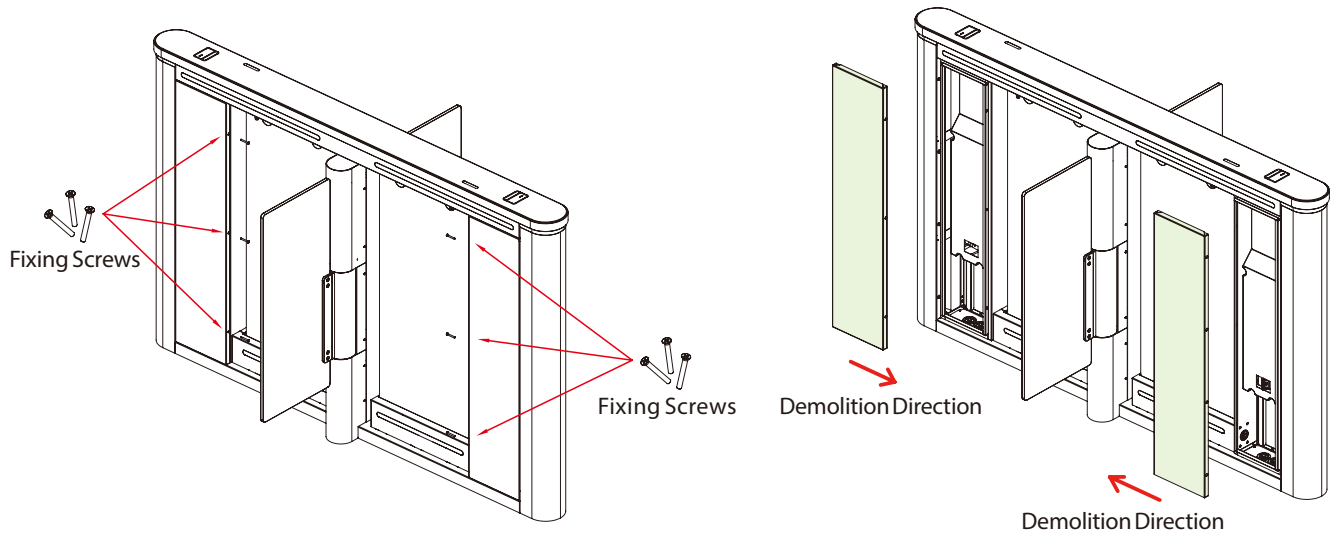

2. Using a Phillips screwdriver, remove the six fixing screws at the locations shown below, then take off the cover plate.

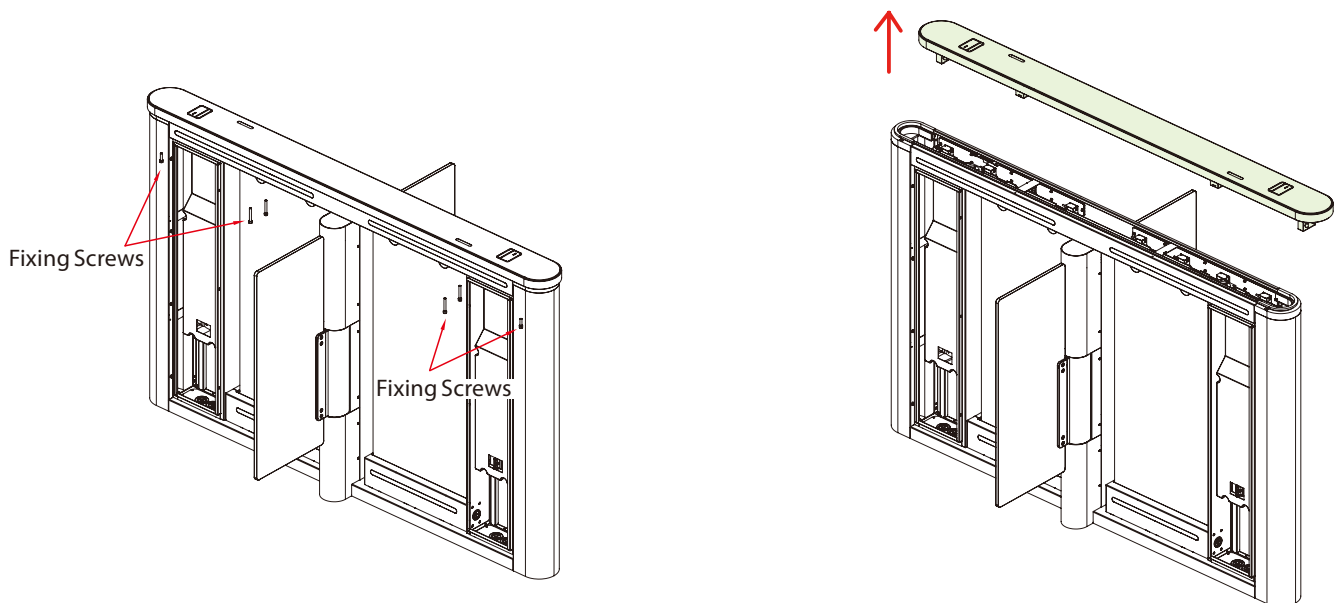

Step 4 Drill Holes and Place Bolts

1. Using a concrete drill bit, drill the mounting holes **2.4" (60mm)** in depth at the center of each marked location.
2. Then insert the bolts vertically into the mounting holes as shown at right.
3. Make sure the bolts are placed in place. Use a hammer to tap the bolts into place, if needed.

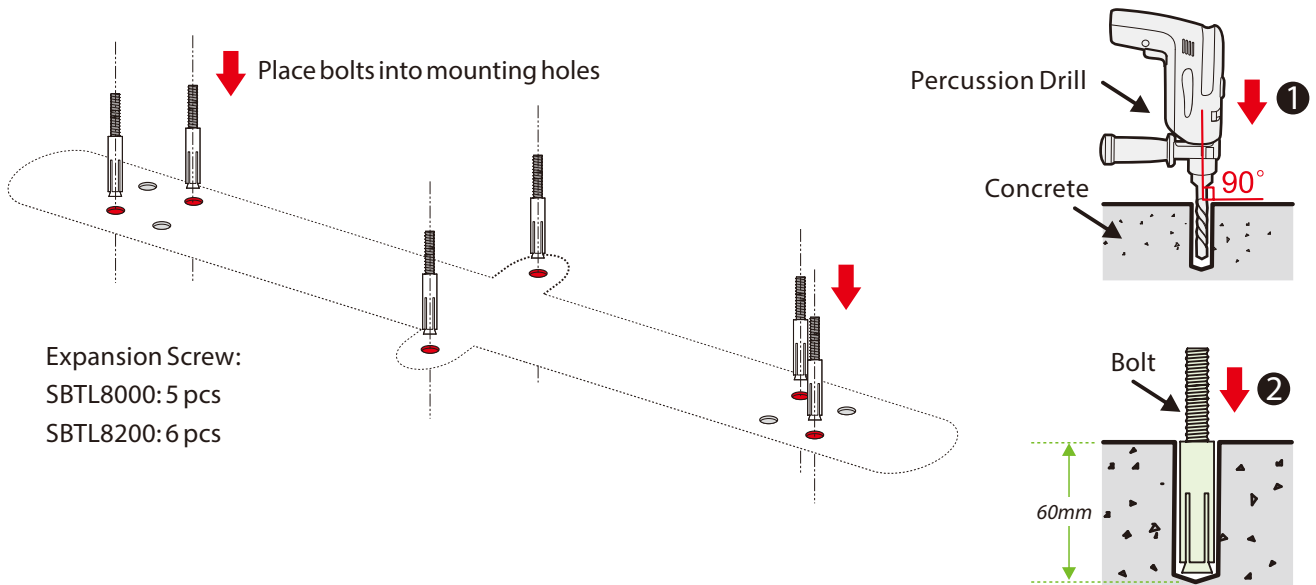

Step 5 Wireway Laying

1. Dig a recess of **2.0" (50mm)** depth between the wire holes on both sides of the channel with the dimensions shown below. Recesses can be dug at positions **1** and **2**.
2. Then lay two **0.8" to 1.0" (20 to 25mm)** diameter PVC pipes as shown below.
3. After threading the cable out of the PVC pipe, pour concrete to fix it in place.

Top View

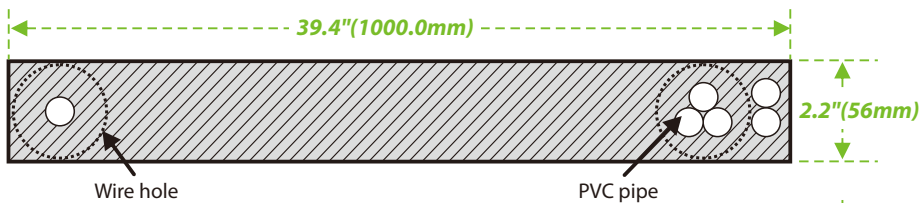

Side View

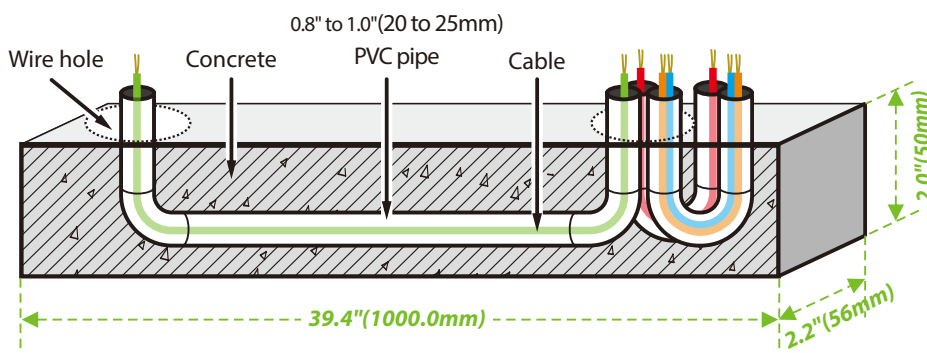
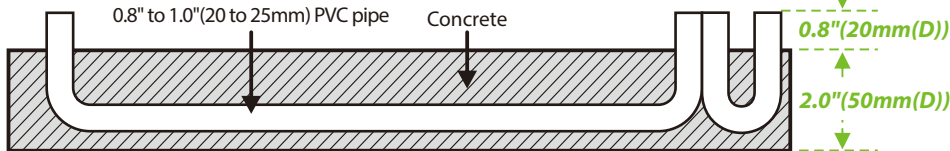

Position of the notch:

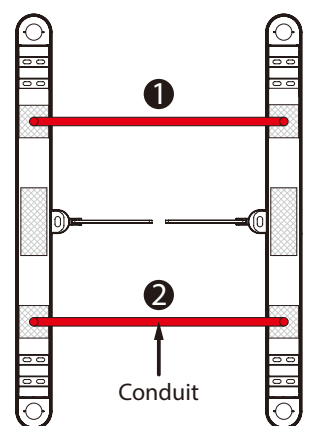

- 4-core Connecting Wire(M-S)
- Ethernet cable / Access control cable
- Ethernet Cable for the Drive
- Power Cable AC110/220V input

Step 6 Secure the Cabinet

1. After laying the PVC pipe, place the cabinet alignment bolts back into the mounting position.
2. Then insert the eight washers and nuts into the bolts one by one.
3. Tighten the nuts to hold the cabinet in place. Don't tighten it completely until after you're sure it won't move anymore. The finished result is shown below:

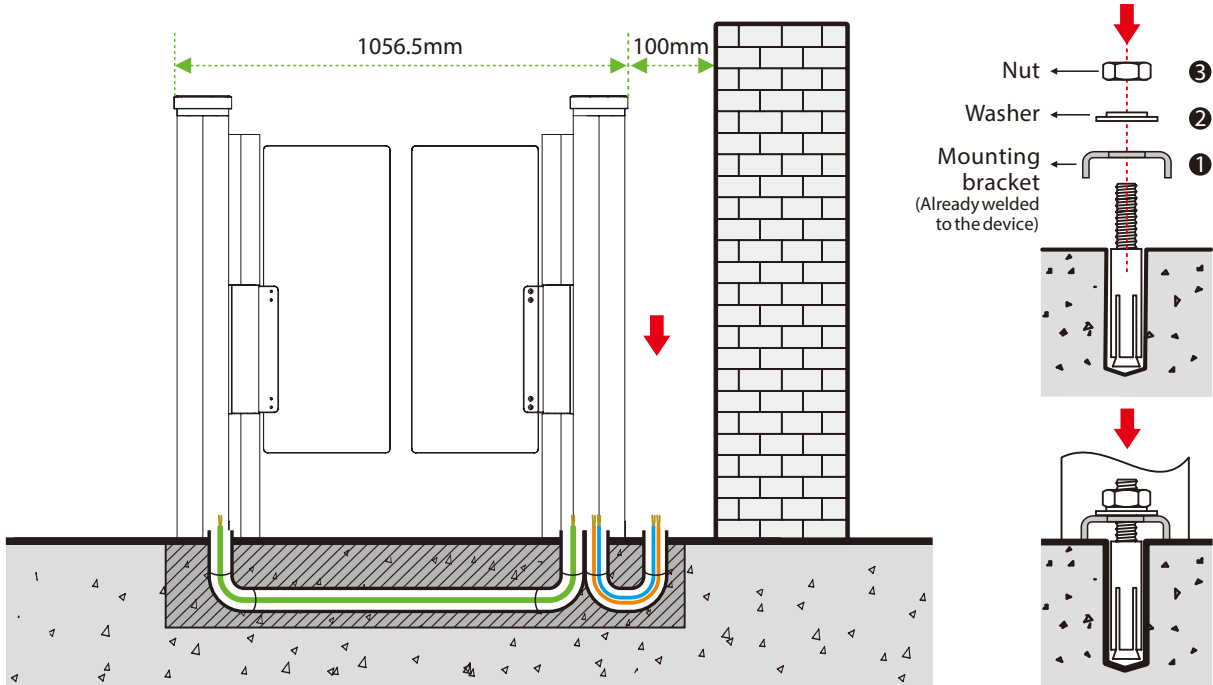

Step 7 Marking the Warning Line

1. It is recommended that warning lines be marked on the ground and used to alert users.
2. A warning line can alert users to wait outside the line until the previous user completes the verification process and passes through the turnstile.

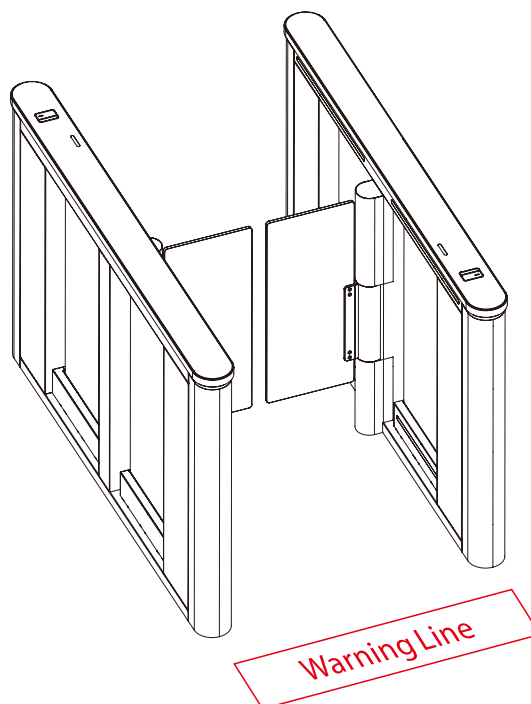

8 Wiring Diagram

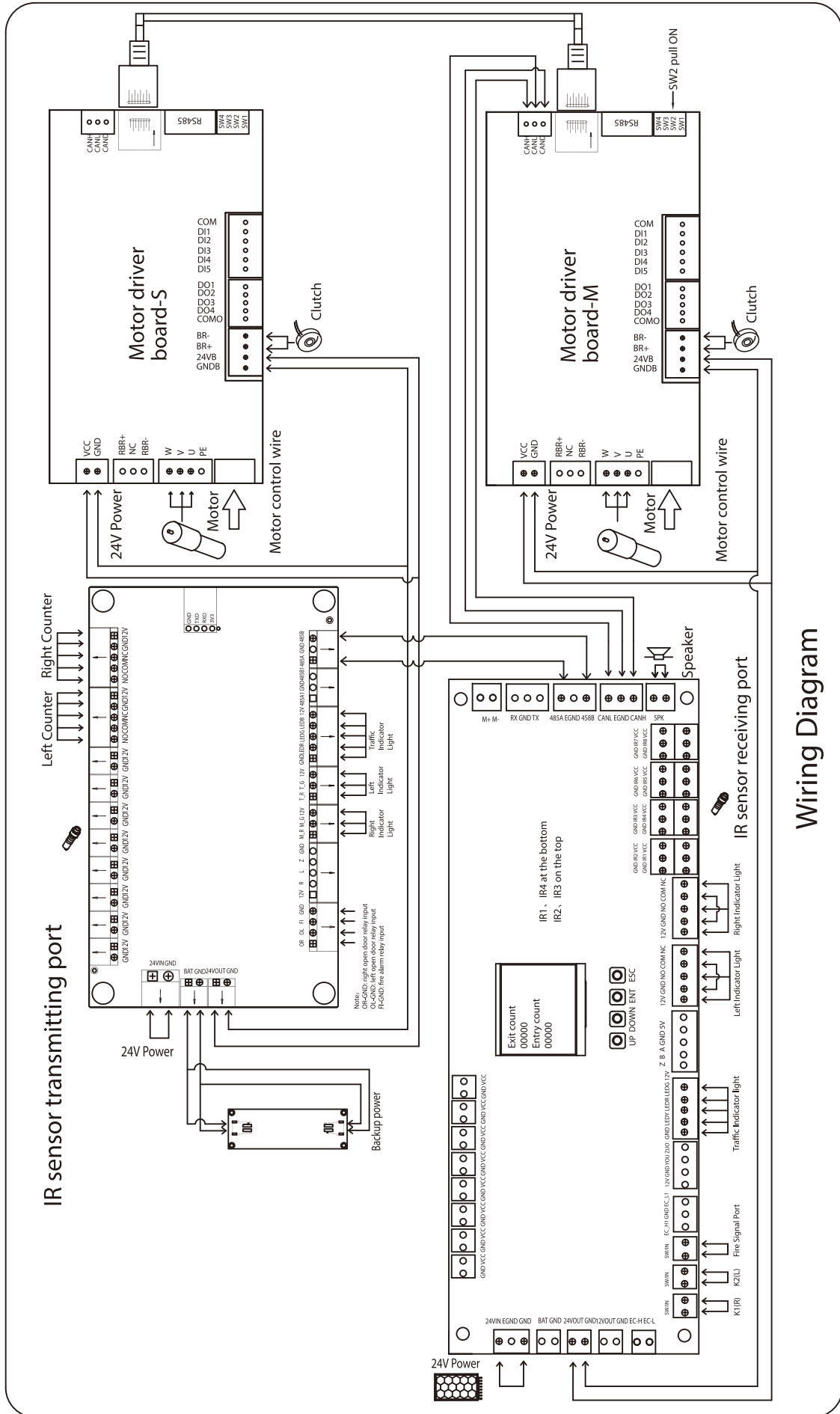

Wiring Diagram