

Table of Contents

Corrosion and Protection of Steel..... 2

- The Corrosion Process 2
- Galvanic Corrosion..... 2
- Corrosion of Steel..... 3
- How Zinc Protects Steel from Corrosion..... 3
 - Barrier Protection..... 3
 - Cathodic Protection..... 3

The Hot-Dip Galvanizing Process..... 4

- Surface Preparation..... 4
- Galvanizing..... 4
- Inspection..... 5

Physical Qualities of Galvanized Coatings..... 5

- The Metallurgical Bond..... 5
- Steel Chemistry..... 5
- GALVXtra®..... 6
- Impact and Abrasion Resistance..... 6
- Corner and Edge Protection..... 7

Performance of Galvanized Coatings..... 7

- Atmospheric Exposure..... 7
- Corrosion Performance in Liquids..... 8
- Corrosion Performance in Freshwater..... 8
- Corrosion Performance in Seawater and Salt Spray..... 8
- Corrosion Performance in Soils..... 9
- Corrosion Performance in Concrete..... 9
- Galvanic Behavior of Zinc in Contact with Other Metals..... 10
 - Contact with Copper and Brass..... 10
 - Contact with Aluminum and Stainless Steel..... 10
 - Contact with Weathering Steel..... 10

Corrosion Resistance of Fully Alloyed Galvanized Coatings..... 10

Performance at Elevated Temperatures..... 10

Welding After Hot-Dip Galvanizing..... 10

- Preparation of Weld Area..... 10
- Touch-up of Weld Area..... 11
- Quality of Welded Joints..... 11
- Fracture Toughness..... 11
- Fatigue Strength..... 11
- Porosity..... 11
- Safety and Health..... 11
- Summary..... 11

Pertinent Specifications..... 12

For corrosion protection of steel products



Corrosion and repair of corrosion damage are multi-billion-dollar problems. Hot-dip galvanizing after fabrication is a cost-effective corrosion control process that solves many corrosion problems in most major industrial applications. Various industries, including chemical, transportation and public utilities, have extensively used hot-dip galvanized steel to combat corrosion.

The value of hot-dip galvanized steel stems from the relative corrosion resistance of zinc, which under most service conditions is considerably better than iron and steel. In addition to forming a physical barrier against corrosion, zinc, applied as a hot-dip galvanized coating, cathodically protects exposed steel. Furthermore, galvanizing for the protection of iron and steel is favored because of its low cost, the ease of application and the extended, maintenance-free service that it provides.



Tandem Turnstile shown with ADA Gate, Infill, and Anti-Climb Canopy Hot-Dip Galvanized

Corrosion and Protection of Steel

The Corrosion Process

Metals are rarely found in their pure state. They almost always are found in chemical combination with one or more nonmetallic elements. Ore is generally an oxidized form of the metal. Significant energy must be used to reduce the ore to pure metal. This energy can be applied via metallurgical or chemical means. Additional energy also may be used in the form of cold working or casting to transform the pure metal into a working shape. Corrosion can be viewed as a tendency for a metal to revert to its natural, lower-energy state. From a thermodynamic perspective, the tendency to decrease in energy is the main driving force behind metallic corrosion.

Galvanic Corrosion

There are two primary types of galvanic cells that cause corrosion: the bi-metallic couple and the concentration cell. A bi-metallic couple (see Fig. 1) is like a battery, consisting of two dissimilar metals immersed in an electrolyte solution. An electric current (flow of electrons) is generated when two electrodes are connected by an external, continuous metallic path. A concentration cell consists of an anode and cathode of the same metal or alloy and a return current path. The electromotive force is provided by a difference in concentration of the solutions contacting the metal(s).

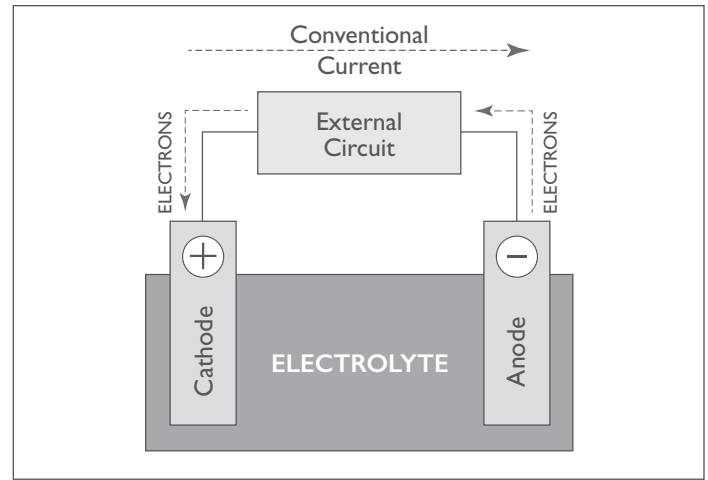

Figure 1: Bi-metallic couple

In a galvanic cell, there are four elements necessary for corrosion to occur:

Anode – This is the electrode where the anode reaction(s) generates electrons. Corrosion occurs at the anode.

Cathode – This is the electrode that receives electrons. The cathode is protected from corrosion.

Electrolyte – This is the conductor through which ion current is carried. Electrolytes include water solutions of acids, bases and salts.

Return Current Path – This is the metallic pathway connecting the anode to the cathode. It is often the underlying metal.

All four elements, anode, cathode, electrolyte and return current path, are necessary for corrosion to occur. Removing any one of these elements will stop the current flow and corrosion will not occur. Substituting a different metal for the anode or cathode may cause the direction of the current to reverse, resulting in a change as to which electrode experiences corrosion. It is possible to construct a table of metals and alloys listed in decreasing order of electrical activity (see Fig. 2). Metals nearer the top of the table are often referred to as less noble metals and have a greater tendency to lose electrons than the more noble metals found lower on the list.

Arrangement of Metals in Galvanic Series:

Any one of these metals and alloys will theoretically corrode while offering protection to any other which is lower in the series, so long as both are electrically connected. In actual practice, however, zinc is by far the most effective in this respect.



Figure 2: Galvanic Series of Metals

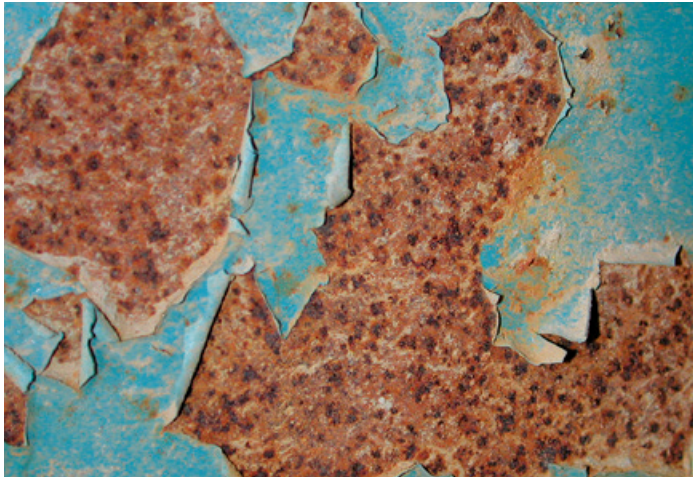

Corrosion of Steel

The actual corrosion process that takes place on a piece of bare, mild steel is very complex due to factors such as variations in the composition/structure of the steel, presence of impurities due to the higher instance of recycled steel, uneven internal stress and/or exposure to a non-uniform environment.

It is very easy for microscopic areas of the exposed metal to become relatively anodic or cathodic. A large number of such areas can develop in a small section of the exposed metal. Further, it is highly possible that several different types of galvanic corrosion cells are present in the same small area of an actively corroding piece of steel.

As the corrosion process progresses, the electrolyte may change due to materials dissolving in or precipitating from the solution. Additionally, corrosion products might tend to build up on certain areas of the metal. These corrosion products do not occupy the same position in the galvanic series as the metallic component of their constituent element. As time goes by, there may be a change in the location of relatively cathodic and anodic areas and previously uncorroded areas of the metal are attacked and corroded. As Fig. 3 indicates, this eventually will result in the uniform corrosion of the area.

The rate at which metals corrode is controlled by factors such as the electrical potential and resistance between anodic and cathodic areas, pH of the electrolyte, temperature and humidity.

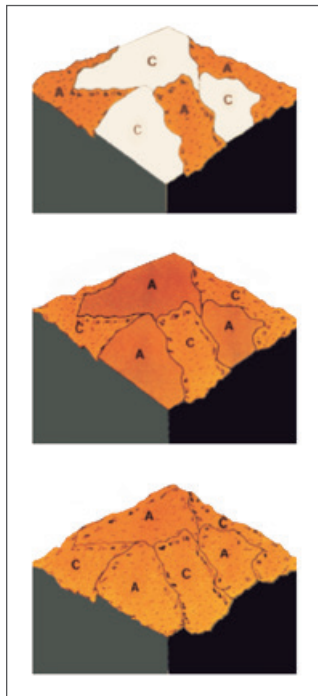

Figure 3: Changes in anodic and cathodic areas

How Zinc Protects Steel from Corrosion

The reason for the extensive use of hot-dip galvanizing is the two-fold protective nature of the coating. As a barrier coating, it provides a tough, metallurgically bonded zinc coating that completely covers the steel surface and seals the steel from the corrosive action of the environment. Additionally, zinc's sacrificial action protects the steel even where damage or minor discontinuity in the coating occurs.

Barrier Protection

Barrier protection is perhaps the oldest and most widely used method of corrosion protection. It acts by isolating the metal from the electrolyte in the environment. Two important properties of the barrier protection are adhesion to the base metal and abrasion resistance. Paint is one example of a barrier protection system.

Cathodic Protection

Cathodic protection is an equally important method for preventing corrosion. Cathodic protection requires changing an element of the corrosion circuit by introducing a new corrosion element, thus ensuring that the base metal becomes the cathodic element of the circuit.

There are two major variations of the cathodic method of corrosion protection. The first is called "the impressed current method." In this method, an external current source is used to impress a cathodic charge on all the iron or steel to be protected. While such systems generally do not use a great deal of electricity, they often are very expensive to install.

The other form of cathodic protection is called "the sacrificial anode method." In this method, a metal or alloy that is anodic to the metal to be protected is placed in the circuit and becomes the anode. The protected metal becomes the cathode and does not corrode. The anode corrodes, thereby providing the desired sacrificial protection. In nearly all electrolytes encountered in everyday use, zinc is anodic to iron and steel. Thus, the galvanized coating provides cathodic corrosion protection as well as barrier protection.



The Hot-Dip Galvanizing Process

The galvanizing process consists of three basic steps: surface preparation, galvanizing and inspection.

Surface Preparation

Surface preparation is the most important step in the application of any coating. In most instances, incorrect or inadequate surface preparation is generally the cause of a coating failing before its expected service lifetime.

The surface preparation step in the galvanizing process has its own built-in means of quality control in that zinc simply will not metallurgically react with a steel surface that is not perfectly clean. Any failures or inadequacies in the surface will immediately be apparent when the steel is withdrawn from the molten zinc because the unclean areas will remain uncoated and immediate corrective actions must be taken.

Once a job has been delivered and accepted at the galvanizer's plant, there is one point of responsibility for ensuring that the material leaves the plant properly galvanized. That point of responsibility is the galvanizer. Job-site painting or other field-applied systems of corrosion protection may involve the use of different subcontractors and/or work groups to prepare the surface and to apply the coating. Paint can only be applied under certain weather conditions. This can result in problems in coordinating activities that lead to costly and time-consuming delays, errors and disputes concerning responsibility and financial liability.

Surface preparation for galvanizing typically consists of three steps: caustic cleaning, acid pickling and fluxing.

Caustic Cleaning – A hot alkali solution often is used to remove organic contaminants such as dirt, grease and oil from the metal surface. Epoxies, vinyls, asphalt, paint or welding slag must be removed before galvanizing by grit-blasting, sandblasting or other mechanical means.

Pickling – Scale and rust normally are removed from the steel surface by pickling in a dilute solution of hot sulfuric acid or ambient temperature hydrochloric acid.

Surface preparation also can be accomplished using abrasive cleaning as an alternative to or in conjunction with chemical cleaning. Abrasive cleaning is a process whereby metallic shot or grit is propelled against the steel material by air blasts or rapidly rotating wheels.

Fluxing – The final surface preparation step in the galvanizing process. Fluxing removes oxides and prevents further oxides from forming on the surface of the metal prior to galvanizing. The method of applying the flux depends upon whether the galvanizer uses the wet or dry galvanizing process.

In the dry galvanizing process (see Fig. 4), the steel or iron is dipped or pre-fluxed in an aqueous solution of zinc ammonium chloride. The material is then dried prior to immersion in molten zinc. In the wet galvanizing process, a blanket of liquid zinc ammonium chloride is floated on top of the molten zinc. The iron or steel being galvanized passes through the flux on its way into the molten zinc.

Galvanizing

In this step, the material is completely immersed in a bath consisting of a minimum of 98% pure molten zinc. The bath chemistry is specified by the American Society for Testing and Materials (ASTM) in Specification B6. The bath temperature is maintained at about 840°F (449°C).

Fabricated items are immersed in the bath until they reach bath temperature. The zinc metal then reacts with the iron on the steel surface to form a zinc-iron intermetallic alloy. The articles are withdrawn slowly from the galvanizing bath and excess zinc is removed by draining, vibrating and/or centrifuging.

The metallurgical reactions that result in the formation and structure of the zinc-iron alloy layers continue after the articles are withdrawn from the bath, as long as these articles are near the bath temperature. The articles are cooled in either water or ambient air immediately after withdrawal from the bath.

Because the galvanizing process involves total material immersion, it is a complete process; all surfaces are coated. Galvanizing provides both outside and inside protection for hollow structures. Hollow structures that are painted have no interior corrosion protection.

Galvanizing is performed at the factory under any weather or humidity conditions. Most brush- and spray-applied coatings depend upon proper weather and humidity conditions for correct application. This dependence on atmospheric conditions often translates into costly construction delays.

The galvanizer's ability to work in any type of weather allows a higher degree of assurance of on-time delivery. Working under these circumstances, galvanizing can be completed quickly and with short lead times.

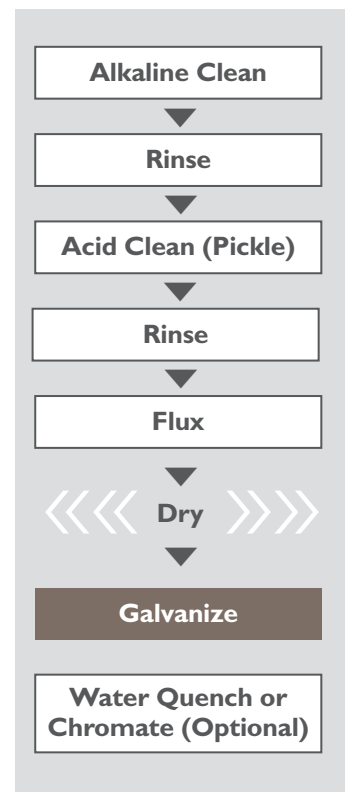

Figure 4: Dry galvanizing process

Inspection

The two properties of the hot-dip galvanized coating that are closely scrutinized after galvanizing are coating thickness and coating appearance. A variety of simple physical and laboratory tests may be performed to determine thickness, uniformity, adherence and appearance.

Products are galvanized according to long-established, well accepted and approved standards of ASTM, the Canadian Standards Association (CSA) and the American Association of State Highway and Transportation Officials (AASHTO). These standards cover everything from minimum required coating thicknesses for various categories of galvanized items to the composition of the zinc metal used in the process.

The inspection process for galvanized items is simple and fast, and requires minimal labor. This is important because the inspection process required to assure the quality of many brush- and spray-applied coatings is highly labor-intensive and uses expensive skilled labor.

Physical Qualities of Galvanized Coatings

The Metallurgical Bond

Galvanizing forms a metallurgical bond combining the zinc and the underlying steel or iron, creating a barrier that is part of the metal itself. During galvanizing, the molten zinc reacts with the iron in the steel to form a series of zinc-iron alloy layers. Fig. 5 is a photomicrograph of a galvanized steel coating's cross-section and shows a typical coating microstructure consisting of three alloy layers and a layer of pure metallic zinc.

The galvanized coating is adherent to the underlying steel on the order of 3600 psi. Other coatings typically offer adhesion rated at several hundred psi, at best.

Steel Chemistry

Knowing the steel chemistry of the material you plan to galvanize is also important. For information on recommended steel composition, refer to ASTM A 385 Standard Practice for Providing High-Quality Zinc Coatings (Hot-Dip). Silicon especially can have a profound effect on the growth of galvanized coatings. (Phosphorus and manganese also increase the reactivity of the steel, and in combination with specific silicon levels, could also produce a thicker matte gray coating.)

The Sandelin Curve (Fig. 6) shows the recommended levels of silicon to produce typical hot-dip galvanized coatings. For highest-quality galvanized coatings, silicon levels should be less than 0.04% OR between 0.15% and 0.23%. Steels outside these ranges, considered reactive steels, can be galvanized, and typically produce an acceptable coating; however, these steels often form a thicker coating, thus a darker appearance should be expected.

Best practice suggests using steels with similar chemistries results in the best possible appearance match. If possible, materials with differing chemistries should be galvanized separately and assembled after galvanizing to match for appearance. Again, it is important to understand corrosion protection is not determined by coating appearance.

Commonly, steel chemistries with atypical levels of silicon, phosphorus, manganese and carbon tend to produce galvanized coatings made up primarily of zinc-iron intermetallic layers, with little or no free zinc layer. When possible, galvanizers should be advised of the grade of steel selected in order to determine whether to utilize special galvanizing techniques that may mitigate the effect of atypical chemistries.

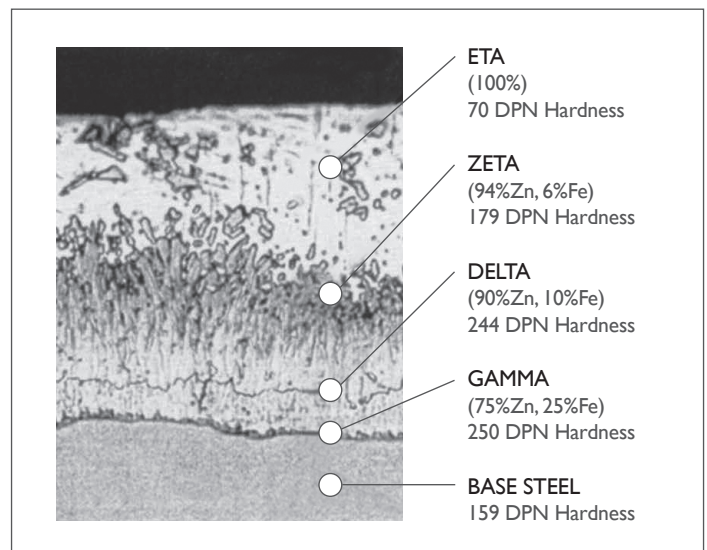

Figure 5: Photomicrograph of galvanized coating

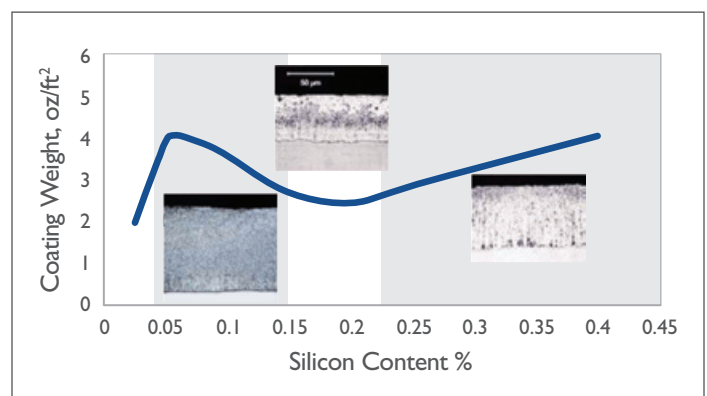

Figure 6: Sandelin Curve

Steel compositions vary depending on requirements for strength and service. Silicon and phosphorus in steel affect the outcome of the galvanizing process by influencing the structure and appearance of the galvanized coating. For example, certain elements present in the steel may result in a coating composed entirely, or almost entirely, of zinc-iron alloy layers (see Fig 7). The appearance will be matte gray but the corrosion protection afforded is unaffected.

This illustrates how important the steel chemistry and surface roughness properties of steel are in regard to coating growth and thickness. Differences in coating thickness are primarily a function of the steel chemistry and surface roughness and usually not a product of the galvanizer's process variables.



Figure 7: Irregular zinc alloy layers

GALVXtra®

Steel is 100% recyclable and 70% of the structural steel used in North America comes from recycled sources. Technology improvements in the steelmaking process have allowed steel companies to produce continuous cast shapes from this recycled steel, which has resulted in significant cost savings. Unfortunately, this technology includes a deoxidizing process which makes the steel shapes highly reactive in a galvanizing zinc bath.

AZZ's GALVXtra® is a field-tested, proprietary zinc bath formulation which mitigates the effects of the steel mill's deoxidizing process, producing a more normally alloyed zinc coating. GALVXtra® meets all of the requirements set forth in ASTM A123, ASTM A153, ASTM B6, CSA and AASHTO.

Impact and Abrasion Resistance

Below the name of each layer in Fig. 5 appears its respective hardness, expressed by a Diamond Pyramid Number (DPN). The DPN is a progressive measure of hardness. The higher the number, the greater the hardness. Typically, the Gamma, Delta and Zeta layers are harder than the underlying steel. The hardness of these layers provides exceptional protection against coating damage through abrasion. The Eta layer of the galvanized coating is quite ductile, providing the coating with some impact resistance.

Hardness, ductility and adherence combine to provide the galvanized coating with unmatched protection against damage caused by rough handling during transportation to and/or at the job site as well as during its service life. The toughness of the galvanized coating is extremely important since barrier protection is dependent upon coating integrity.

Other coatings damage easily during shipment or through rough handling on the job site. Experts will argue that all organic forms of barrier protection (such as paint) by their nature are permeable to some degree. Correctly applied galvanized coatings are impermeable.

If the galvanized coating is physically damaged, it will continue to provide cathodic protection to the exposed steel. If individual areas of underlying steel or iron become exposed by up to a 1/4"-diameter spot, the surrounding zinc will provide these areas with cathodic protection for as long as the coating lasts.

Fig. 8 shows how corrosion will begin and immediately progress at a scratch or gap in a paint coating. Fig. 9 shows how corrosion will be prevented at a scratch or gap in a zinc coating.

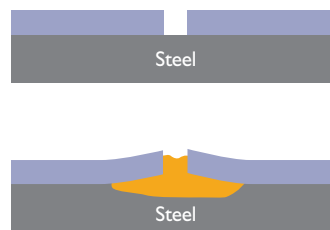

Figure 8: Rust undercuts scratched paint

Paint on Steel

This is what happens at a scratch on painted steel. The exposed steel corrodes and forms a pocket of rust. Because rust is much more voluminous than steel, the pocket swells. This lifts the paint film from the metal surface to form a blister. Both the corrosion pit and the blister continue to grow.

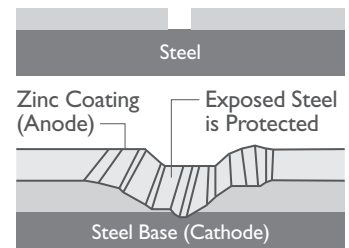

Figure 9: Zinc protects base steel, even when scratched

Galvanized Steel

This is what happens at a scratch on galvanized steel. The zinc coating sacrifices itself slowly by galvanic action to protect the base steel. This sacrificial action continues as long as any zinc remains in the immediate area.

Corner and Edge Protection

The galvanizing process naturally produces coatings that are at least as thick at the corners and edges as the coating on the rest of the article. As coating damage is most likely to occur at the edges, this is where added protection is needed most. Brush- or spray-applied coatings have a natural tendency to thin at corners and edges. Fig. 10 is a photomicrograph showing a cross-section of an edge of a piece of galvanized steel.

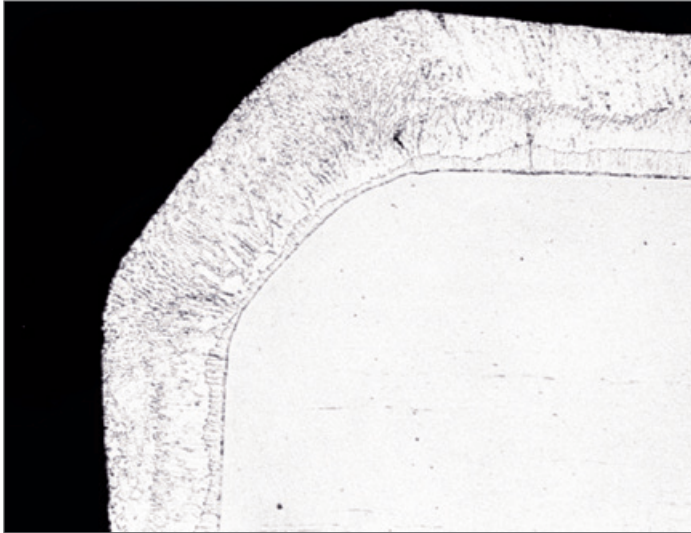

Figure 10: Full corner protection

Performance of Galvanized Coatings

Galvanized coatings have a proven performance under numerous environmental conditions. The corrosion resistance of zinc coatings is determined primarily by the thickness of the coating but varies with the severity of environmental conditions.

The predictability of the lifetime of a coating is important for planning and financing required maintenance. Measurements of the actual rate of consumption of the galvanized coating during the first few years of service often provide good data for projecting remaining life until first maintenance. Due to the buildup of zinc corrosion products, which in many environments are adherent and fairly insoluble, the corrosion rate may slow as time progresses. **Therefore, predictions of time to first maintenance that are based on initial corrosion rates of zinc coatings are often conservative.**

Environments in which galvanized steel and iron are commonly used include indoor and outdoor atmospheres, the storage of hundreds of different chemicals, in freshwater, seawater, soils and/or concrete. Because of the many years galvanizing has been used for corrosion protection, a wealth of real-world, long-term exposure data on zinc coating performance in a wide variety of environments is available.

Atmospheric Exposure

Zinc oxide is the initial corrosion product of zinc in relatively dry air. This is formed by a reaction between the zinc and atmospheric oxygen. In the presence of moisture, this can be converted to zinc hydroxide. The zinc hydroxide and zinc oxide further react with carbon dioxide in the air to form zinc carbonate. **The zinc carbonate film is tightly adherent and relatively insoluble. It is primarily responsible for the excellent and long-lasting corrosion protection provided by the galvanized coating in most atmospheric environments.**

Since 1926, ASTM Committees A05 (Metallic-Coated Iron and Steel Products), G01 (Corrosion of Metals) and others have been collecting records of zinc coating behavior under various categories of atmospheric conditions. These atmospheric exposure tests are conducted throughout North America to obtain corrosion rate data for zinc exposed in various atmospheres. Precise comparison of the corrosion behavior of the galvanized coating in various atmospheric environments is influenced by many factors. Such factors include prevailing wind direction, type and density of corrosive fumes and pollutants, amount of sea spray, number of wetting and drying cycles, and the duration of exposure to moisture. Although there is a range in observed corrosion rates, actual observed rates rarely exceed 0.3 mils per year. It is also worthwhile to note that when exposed indoors, the life of the galvanized coating will be at least two to three times that expected with outdoor exposure in the same environment.

Fig. 11 is a plot of the thickness of the galvanized coating against the expected time to first service of the coating under outdoor exposure conditions. This data is a compilation of many exposure tests of zinc-coated steel since the 1920s. Today's atmosphere has substantially improved through antipollution campaigns, so the data curves represent a conservative portrayal of the performance of zinc coatings in the 21st century.

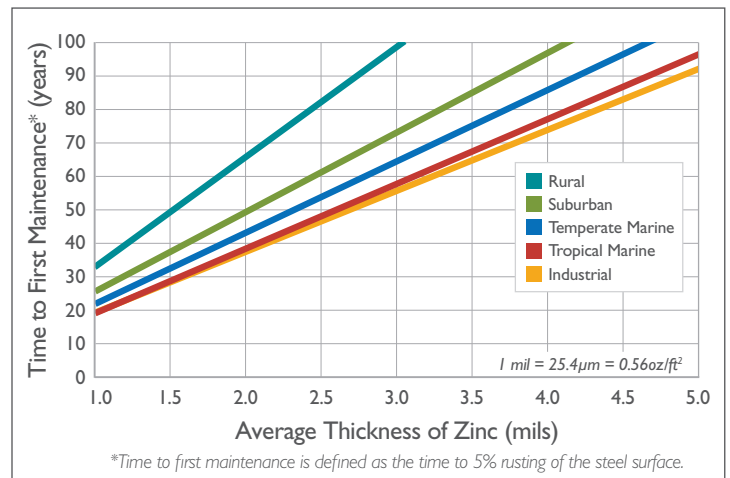

Figure 11: Time to first maintenance vs. coating thickness and type of atmosphere

Time to first maintenance is defined as the time until 5% of the surface is showing iron oxide (red rust). At this stage, it is unlikely that the underlying steel or iron has been weakened or that the integrity of the structure protected by the galvanized coating has been compromised through corrosion. Enough of the galvanized coating remains to provide a good substrate for implementation of an appropriately selected brush- or spray-applied corrosion protection system. Exposure atmospheres may be divided into five types. They are:

Moderately Industrial – These environments generally are the most aggressive in terms of corrosion. Air emissions may contain some sulfides and phosphates that cause the most rapid zinc coating consumption. Automobile, truck and plant exhaust are examples of these emissions. Most city or urban area atmospheres are classified as moderately industrial.

Suburban – These atmospheres are generally less corrosive than moderately industrial areas. As the term suggests, they are found in the largely residential perimeter communities of the urban or city areas.

Temperate Marine – The time to first maintenance of galvanized coatings in marine environments is influenced by proximity to the coastline and prevailing wind direction and intensity. In marine air, zinc corrosion follows a different mechanism; chlorides from the sea spray can react with the normally protective zinc corrosion products to form soluble zinc chlorides. When these chlorides are washed away, fresh zinc is exposed to corrosion. The addition of calcium or magnesium salts to the surface of the zinc can extend the service life of the coating.

Tropical Marine – These environments are similar to temperate marine atmospheres except they are found in warmer climates. Possibly because many tropical areas are often relatively far removed from heavy industrial or even moderately industrial areas, tropical marine climates tend to be somewhat less corrosive than temperate marine climates.

Rural – These are usually the least aggressive of the five atmospheric types. This is primarily due to the relatively low level of sulfur and other emissions found in such environments.

Corrosion Performance in Liquids

A primary factor governing galvanized coating corrosion behavior in liquid chemical environments is the solution's pH. Galvanizing performs well in solutions of pH above 4.0 and below 12.5 (see Fig. 12). This should not be considered a hard and fast rule, because factors such as agitation, aeration, temperature, polarization and the presence of inhibitors also may change the corrosion rate. Within the pH range of 4.0 to 12.5, a protective film forms on the zinc surface and the galvanized coating protects the steel by slowing corrosion to a very low rate. The protective film's exact chemical composition is somewhat dependent upon the specific chemical environment.

Since many liquids fall within the pH range of 4.0 to 12.5, galvanized steel containers are widely used in storing and transporting many chemical solutions.

Corrosion Performance in Freshwater

Galvanizing is successfully used to protect steel in freshwater exposure. "Freshwater" refers to all forms of water except seawater. Freshwater may be classified according to its origin or application. Included are hot and cold domestic, industrial, river, lake and canal waters. Corrosion of zinc in freshwater is a complex process controlled largely by impurities in the water. Even rainwater contains oxygen, nitrogen, carbon dioxide and other dissolved gases, in addition to dust and smoke particles.

Ground water carries microorganisms, eroded soil, decaying vegetation, dissolved salts of calcium, magnesium, iron and manganese, and suspended colloidal matter. All of these substances and other factors such as pH, temperature and motion affect the structure and composition of the corrosion products formed on the exposed zinc surface. Relatively small differences in freshwater content or conditions can produce relatively substantial changes in corrosion products and rate. Thus, there is no simple rule governing the corrosion rate of zinc in freshwater.

Hard water is much less corrosive than soft water. Under conditions of moderate or high water hardness, a natural scale of insoluble salts tends to form on the galvanized surface. These combine with zinc to form a protective barrier of calcium carbonate and basic zinc carbonate.

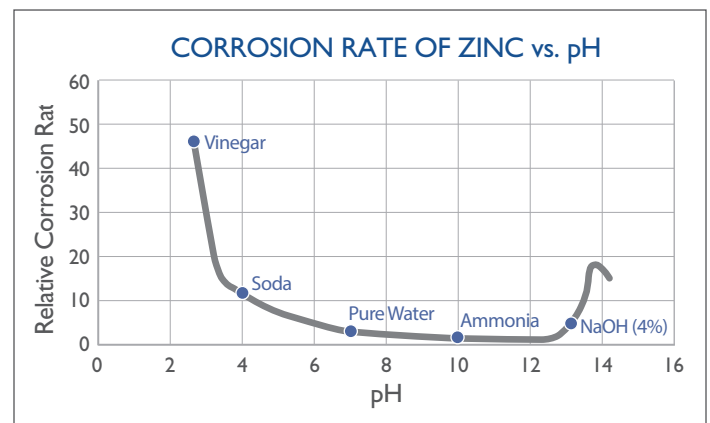

Figure 12: Effect of pH on corrosion of zinc

Corrosion Performance in Seawater and Salt Spray

Galvanized coatings provide considerable protection to steel immersed in seawater and exposed to salt spray. The factors that influence the corrosion of zinc in freshwater also apply to seawater. However, it is the dissolved salts (primarily sulfides and chlorides) in seawater that are the principal determinants of the corrosion behavior of zinc immersed in seawater. Given the high level of chloride in seawater, a very high rate of zinc corrosion might be expected. However, the presence of magnesium and calcium ions in seawater has a strong inhibiting effect on zinc corrosion in this type of environment. Accelerated laboratory test results that sometimes use a simple sodium chloride (NaCl) solution to simulate the effects of seawater exposure on galvanized steel should be viewed skeptically. Real-world results often differ significantly from accelerated laboratory tests.

Corrosion Performance in Soils

More than 200 different types of soils have been identified and are categorized according to texture, color and natural drainage. Coarse and textured soils, such as gravel and sand, permit free circulation of air, and the process of corrosion may closely resemble atmospheric corrosion. Clay and silt soils have a fine texture and hold water, resulting in poor aeration and drainage. The corrosion process in such soils may resemble the corrosion process in water.

The National Bureau of Standards has conducted an extensive research program on the corrosion of metals in soils. Some of its research on galvanized steel pipe dates back to 1924. The results from the NBS study are based on tests started in 1937 using 1½" (38mm) steel pipe with a nominal 3 oz. per square foot (5.3 mil) zinc coating. Data collected (but not displayed here) also show that the galvanized coating will prevent pitting of steel in soil, just as it does in atmospheric exposure. Even in instances where the zinc coating was completely consumed, the corrosion of the underlying steel was much less than that of bare steel specimens exposed to identical conditions.

Corrosion Performance in Concrete

Concrete is an extremely complex material. The use of various types of concrete in construction has made the chemical, physical and mechanical properties of concrete and their relationship to metals a topic of ongoing studies. Steel wire or reinforcing bars (rebar) often are embedded in concrete to provide added strength.

Since rebar is not visible after it is embedded in concrete, corrosion protection is very important to retain structural integrity. Galvanized rebar has demonstrated corrosion protection for many years in corrosive atmospheres such as Bermuda. As the corrosion products of zinc are much less voluminous than those of steel, the cracking, delamination and spalling cycle of concrete is greatly reduced when using galvanized rebar. Laboratory data support and field test results confirm that reinforced concrete structures exposed to aggressive environments have a substantially longer service life when galvanized rebar is used as opposed to bare steel rebar.

The bond strength between galvanized rebar and concrete is excellent. However, it often takes slightly longer to develop than the bond between bare rebar and concrete. According to laboratory and field tests, the bond between galvanized rebar and concrete is in fact stronger than the bond between bare rebar and concrete- or epoxy-coated rebar and concrete (see Fig. 14). A comparison of the qualitative and quantitative characteristics of galvanized reinforcing steel and epoxy-coated rebar is shown in Fig. 15.

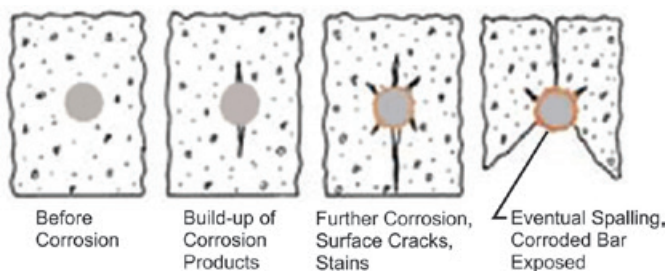

Figure 13: Spalling concrete

Information and additional studies about the uses and behavior of galvanized reinforcement in concrete can be found in these publications available from the AGA or your local galvanizer:

- Galvanizing for Corrosion Protection: A Specifier's Guide to Reinforcing Steel
- Rebar: A Processing and Inspection Guide for Quality Hot-Dip Galvanized Reinforcing Steel

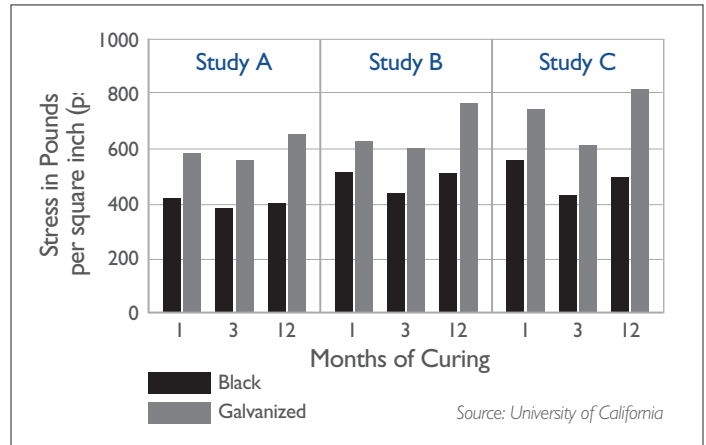

Figure 14: Bond strength to concrete, black vs. reinforcing steel

Figure 15: Comparison of epoxy-coated and hot-dip galvanized reinforcing steel

Comment	Hot-Dip Galvanized	Epoxy-Coated
Earliest use	Early 1900s	1977
Requires care in handling	No	Yes
Can be dragged on ground	Yes	No
MUST be touched up	No	Yes
Has barrier protection	Yes	Yes
Has cathodic protection	Yes	No
Bond strength to concrete	Excellent	Poor
UV resistance	Good	Questionable
After fabrication application	Simple	Difficult
Widely used	Yes	Yes
Cost	Comparable	Comparable*
Lead time	1-3 days	3 weeks
Availability of coating for other embedded items	Readily Available	Scarce

*Epoxy prices vary widely throughout U.S. and Canada and wide variations should be expected.

Figure 16: Elemental map of galvanized rebar. The corrosion products of galvanized rebar are less dense and do not build up pressure to cause concrete spalling (unlike the dense corrosion products of bare steel). The zinc corrosion products (depicted right, in white), migrate away from the galvanized coating and disperse into the concrete matrix.



Galvanic Behavior of Zinc in Contact with Other Metals

Where zinc comes into contact with another metal, the potential for corrosion through a bi-metallic couple exists. The extent of the corrosion depends upon the position of the other metal relative to zinc in the galvanic series (see Fig. 2, page 2).

Contact with Copper and Brass

If an installation requires contact between galvanized materials and copper or brass in a moist or humid environment, rapid corrosion may occur. Even runoff water from copper or brass surfaces can contain enough dissolved copper to cause rapid corrosion. If the use of copper or brass in contact with galvanized items is unavoidable, precautions should be taken to prevent electrical contact between the two metals. Joint faces should be insulated with non-conducting gaskets; connections should be made with insulating, grommet-type fasteners. The design should ensure that water is not recirculated and that water flows from the galvanized surface toward the copper or brass surface and not the reverse.

Contact with Aluminum and Stainless Steel

Under atmospheric conditions of moderate to mild humidity, contact between a galvanized surface and aluminum or stainless steel is unlikely to cause substantial incremental corrosion. However, under very humid conditions, the galvanized surface may require electrical isolation through the use of paint or joining compounds.

Contact with Weathering Steel

When galvanized bolts are used on weathering steel, the zinc will initially sacrifice itself until a protective layer of rust develops on the weathering steel. Once this rust layer develops, it forms an insulating layer that prevents further sacrificial action from the zinc. The zinc coating has to be thick enough to last until the rust layer forms, usually several years. Most hot-dip galvanized bolts have enough zinc coating to last until the protective rust layer develops on the weathering steel, with only minimal loss in coating life.

Corrosion Resistance of Fully Alloyed Galvanized Coatings

The corrosion protection and service life of galvanized coatings are not affected by differences in surface appearances. While some steels may produce freshly galvanized coatings with matte gray or mottled appearances, their corrosion protection is not impaired. Even when a reddish-brown discoloration prematurely develops upon exposure of the coatings, it is an aesthetic effect and should not be mistaken for corrosion of underlying steel.

Premature staining is a surface effect caused by corrosion of iron contained in the zinc-iron alloy layers of a galvanized coating. Such a condition is more likely to develop when reactive steels (such as those containing relatively high silicon) are galvanized. While steel chemistry may result in the zinc-iron alloy phase extending throughout the galvanized coating, corrosion protection is not reduced. Long-term exposure testing has shown that for equal coating thickness and identical exposure conditions, the corrosion protection provided by the coating on more reactive, silicon-containing steels is similar to that of less reactive steels.

Performance at Elevated Temperatures

Galvanized coatings perform well under continuous exposure to temperatures up to 392°F (200°C). Exposure to temperatures above this can cause the outer free zinc layer to peel from the underlying zinc-iron alloy layer. However, the remaining zinc-iron alloy layer will provide good corrosion resistance and will continue to protect the steel for a long time, depending upon its thickness.

Welding After Hot-Dip Galvanizing

All commonly practiced welding and cutting techniques can be used on galvanized steel (see American Welding Society's [AWS] specification D – 19.0, Welding Zinc-Coated Steel). Welding on galvanized steel is usually necessary if the final structure is too large to be dipped in a galvanizing bath or for structures that must be welded in the field.

Preparation of Weld Area

AWS D – 19.0, Welding Zinc-Coated Steel, calls for welds to be made on steel that is free of zinc in the area to be welded. Thus, for galvanized structural components of a fabrication, the zinc coating should be removed at least one to four inches (2.5 – 10 cm) from either side of the intended weld zone and on both sides of the work piece. Grinding back the zinc coating is the preferred and most common method; burning the zinc away or pushing back the molten zinc from the weld area also are effective.

Touch-up of Weld Area

Any welding process on galvanized surfaces destroys the zinc coating on and around the weld area. Restoration of the area should be performed in accordance with ASTM A 780, Standard Practice for Repair of Damaged and Uncoated Areas of Hot-Dip Galvanized Coatings, which specifies the use of paints containing zinc dust, zinc-based solders or sprayed zinc. All touch-up and repair methods are capable of building a protective layer to the thickness required by ASTM A 780.

The restored area of the zinc coating will have no effect on the overall lifetime of the part. Repair materials and their coating thickness have been chosen to give comparable lifetimes to the coating minimums required by ASTM A 123/A 123M, Standard Specification for Zinc (Hot-Dip Galvanized) Coatings on Iron and Steel Products. There may be some visual differences between the original hot-dip galvanized coating and the restored area, but, over time, the natural weathering of the galvanized coating and the repair material yield similar appearances.

Quality of Welded Joints

It is recommended in AWS D – 19.0 to remove all zinc from the weld area prior to welding because burning through the zinc slows the welding process, generates zinc fumes (see “Safety and Health” at right) and creates an unsightly burn area around the weld.

However, as studies performed by the International Lead Zinc Research Organization (ILZRO) have shown, the tensile, bend and impact properties of welds on galvanized steel are equivalent to the properties of welds on uncoated steel.

Fracture Toughness

Tests establish that the fracture toughness properties of welds are unaffected by the presence of galvanized coatings.

Fatigue Strength

The fatigue strength of arc welds on galvanized steel is equivalent to welds on uncoated steel made by CO₂ welding.

Porosity

The extent of weld porosity is a function of heat input and the solidification rate of the weld metal. Not always possible to eliminate, porosity affects the fatigue strength and cracking tendencies of welds. When welds are subject to fatigue loading, welds on galvanized steel should be made oversized to reduce the influence of any weld metal porosity.

When evaluating the effect of porosity on the fatigue strength of a fillet weld, it is necessary to consider both the function of the joint and the weld size. When a fillet weld on galvanized steel is large enough relative to plate thickness to fail by fatigue from the toe of the weld in the same manner as in uncoated steel, the presence of porosity in the weld does not reduce the fatigue strength of the joint.

Where the dimensions of the weld are just large enough to cause fatigue failure from the toe in a sound weld, a weld containing porosity at the root may fail preferentially through the throat of the weld. Intergranular cracking of fillet welds containing porosity, sometimes referred to as zinc penetrator cracking, does not significantly affect the strength of non-critical joints. For more critical stress applications, it is advisable to carry out procedural tests on materials and samples.

Safety and Health

All welding processes produce fumes and gases to a greater or lesser extent. Manufacturers and welders must identify the hazards associated with welding coated and uncoated steel and workers must be trained to maintain work practices within Occupational Safety and Health Administration (OSHA) regulations. In general, welding on steel with the zinc coating ground back away from the weld area will produce lead and zinc oxide emissions below OSHA permissible exposure limits (PELs) for zinc and lead. When welding directly on galvanized steel is unavoidable, PELs may be exceeded and every precaution, including high-velocity circulating fans with filters, air respirators and fume-extraction systems suggested by AWS, should be employed.

Fumes from welding galvanized steel can contain zinc, iron and lead. Fume composition typically depends on the composition of materials used, as well as the heat applied by the particular welding process. In any event, good ventilation minimizes the amount of exposure to fumes. Prior to welding on any metal, consult ANSI/ASC Z-49.1, Safety In Welding, Cutting and Allied Processes, which contains information on the protection of personnel and the general area, ventilation and fire prevention.

Summary

With proper preparation of the weld area, selection of a suitable welding material and process, and careful touch-up of the weld area, welding on galvanized steel provides an excellent product for use in myriad applications, from bridges, towers and grating to handrail, trusses and guardrail.

Pertinent Specifications**American Society for Testing and Materials**

A 123/A 123M	Standard Specification for Zinc (Hot-Dip Galvanized) Coatings on Iron and Steel Products
A 143-74	Standard Practice for Safeguarding Against Embrittlement of Hot-Dip Galvanized Structural Steel Products and Procedure for Detecting Embrittlement
A 153/A 153M	Standard Specification for Zinc Coating (Hot-Dip) on Iron and Steel Hardware
A 384	Standard Practice for Safeguarding Against Warpage and Distortion During Hot-Dip Galvanizing of Steel Assemblies
A 385	Standard Practice for Providing High-Quality Zinc Coatings (Hot-Dip)
A 767/A 767M	Standard Specification for Zinc-Coated (Galvanized) Steel Bars for Concrete Reinforcement
A 780	Specification for Repair of Damaged and Uncoated Areas of Hot-Dip Galvanized Coatings
B 6	Standard Specification for Zinc
D 6386	Standard Practice for Preparation of Zinc (Hot-Dip Galvanized) Coated Iron and Steel Product and Hardware Surfaces for Painting
E 376	Standard Practice for Measuring Coating Thickness by Magnetic Field or Eddy-Current (Electromagnetic) Test Methods

Canadian Standards Association

G 164-M	Hot-Dip Galvanizing of Irregularly Shaped Articles
---------	--

The material in this publication has been developed by the American Galvanizers Association, Inc. to provide accurate, authoritative information regarding iron and steel products hot-dip galvanized after fabrication and is based on recognized engineering principles and inspection practices. This material is for general information only and is not intended as a substitute for competent professional examination and verification of accuracy, suitability and/or applicability. The publication of the material contained herein is not intended as a representation or warranty on the part of the American Galvanizers Association, Inc. Anyone making use of this information assumes all liability arising from such use.